

**The Great Grid Upgrade**

Grimsby to Walpole

# Grimsby to Walpole

New Walpole Substation Location Options Report

January 2024



**nationalgrid**

# Contents

---

<b>1.</b>	<b>Introduction</b>	<b>6</b>
<b>2.</b>	<b>Further Development of Configuration Options</b>	<b>10</b>
2.1	Introduction	10
2.2	Option Development	11
<b>3.</b>	<b>Options Assessment Process</b>	<b>14</b>
<b>4.</b>	<b>Appraisal of Options</b>	<b>16</b>
4.1	Introduction	16
4.2	Option C	16
4.3	Option D	20
4.4	Option E	23
4.5	Option F	26
4.6	Summary of options	29
<b>5.</b>	<b>Appraisal of Options</b>	<b>32</b>
5.1	Preferred Options	32
<b>6.</b>	<b>Conclusion and Next Steps</b>	<b>34</b>
6.1	Overview	34
6.2	Next steps	35
	<b>Appendix A</b>	<b>38</b>
	<b>Appendix B</b>	<b>47</b>

# Executive Summary

## Purpose of this Report

This Report details the further work that has been undertaken in relation to the preferred location of the proposed new Walpole substation. Whilst the SOR, as amended by the Addendum to Strategic Options Report (SOR Addendum), identifies the need for the new Walpole substation, it does not specify its geographical location. This Report therefore deals with the locations on the electricity network and resultant changes to its configuration that are appropriate for a new Walpole substation.

## Background

The consideration of strategic options is part of an iterative process in response to interaction between a range of emerging energy projects and customer requirements. National Grid Electricity Transmission (NGET) has undertaken additional work to further refine the preferred strategic option for the southern connection point of the Grimsby to Walpole project.

The SOR, as amended by the SOR Addendum, identified preferred strategic options that would meet the needs case for the two areas identified within the Humber/Trent (Creyke Beck area generation group) and Lincolnshire (East Coast generation group) regions. The preferred strategic options were identified as:

- To resolve Issue (a)<sup>1</sup> Creyke Beck substation to new High Marnham substation (ECO 1) (assigned the project title of “North Humber to High Marnham”)
- To resolve Issue (b)<sup>2</sup> New Grimsby West to new Lincolnshire Connection substation(s), new Lincolnshire Connection substation(s) via a new Weston Marsh substation<sup>3</sup> to a new Walpole substation<sup>4</sup> (ECO 6) (assigned the project title by NGET of “Grimsby to Walpole”). This is the focus of the present Report.

The SOR, as amended by the SOR Addendum, concludes that the project should include a new Walpole substation, but the physical location is not identified in the document. The preferred strategic option it selects, ECO 6, consists of a new 400 kV overhead line connection from new Grimsby West to a new Walpole substation via the Lincolnshire Connection Substation(s) and a new Weston Marsh substation. However, the SOR, as amended by the SOR Addendum, does not consider the electrical configuration in which the new Walpole substation would connect into the wider transmission system. The geographical location of the new Walpole substation is dependent on the location of the existing circuit it will connect into. Due to a large geographical spread of possible circuit options, this resulted in a large study area being defined surrounding the existing Walpole substation. Further technical and environmental appraisals were then

---

<sup>1</sup> See paragraph 6.1.4 of the SOR

<sup>2</sup> See paragraph 6.1.4 of the SOR

<sup>3</sup> The new Weston Marsh substation refers to a proposed new substation assumed to be at a location close to the existing 4ZM route, with the exact location subject to routing and siting.

<sup>4</sup>The new Walpole substation refers to a proposed new substation in the regional vicinity of the existing Walpole substation to provide additional connection capacity in the area. It should be noted that the new substation would not replace the existing Walpole substation and both substations will be operational following the completion of the Grimsby to Walpole project.

needed to provide the additional refinement of system configurations and geographical search area required to allow routeing and siting to be commenced.

## Configuration options considered

In total, six electrical configuration options were considered, with some being discounted early in the process due to the failure to meet the strategic needs case for the Grimsby to Walpole project (i.e. Options A and B). Therefore, the configuration options taken forward for detailed consideration were:

- **Option C (Figure 4. 1)** New Grimsby West to new Lincolnshire Connection substation(s), new Lincolnshire Connection substation(s) to the new Walpole substation, where the new Walpole substation is located along the existing Burwell to Walpole circuit (4ZM), with EGL3 and EGL4 HVDC underground cables connecting at the new Walpole substation.
- **Option D (Figure 4. 2)** New Grimsby West to new Lincolnshire Connection substation(s), new Lincolnshire Connection substation(s) to the new Walpole substation, where the new Walpole substation is located along the Burwell to Walpole circuit, with EGL3 and EGL4 HVDC underground cables connecting at the new Walpole substation, together with a second new 400 kV substation (Weston Marsh).
- **Option E (Figure 4. 3)** New Grimsby West to new Lincolnshire Connection substation(s), new Lincolnshire Connection substation(s) to the existing Walpole substation (using bays vacated by a reconfiguration of the existing 4ZM circuits). The new Walpole substation is located along the Burwell to Walpole circuit, with EGL3 and EGL4 HVDC underground cables connecting at the new Walpole substation. The existing Bicker Fen-Walpole and Bicker Fen-Spalding North-Walpole circuits are diverted into the new Walpole substation.
- **Option F (Figure 4. 4)** New Grimsby West to new Lincolnshire Connection substation(s), new Lincolnshire Connection substation(s) to the new Walpole substation, where the new Walpole substation is located along the Norwich Main to Walpole circuits, with EGL3 and EGL4 HVDC underground cables connecting at the new Walpole substation.

The appraisal of options considered the likely environmental and socioeconomic effects, technical issues and cost that would be associated with each configuration option. The key environmental and socioeconomic constraints affecting all four options are very similar, however Option F is least preferred for a variety of environmental and socioeconomic reasons including close proximity to designated sites along the Norfolk coast and the longer overhead line and HVDC underground cable lengths. Option F also offers the lowest boundary uplift of the four options. Options D and E have high outage<sup>5</sup> complexity compared with Options C and F. Option C has the highest cost (including capital, lifetime and secondary costs) due to the additional Sealing End Compound infrastructure, with Option E providing the lowest capital cost.

---

<sup>5</sup> Significant work, such as a new connection- requires power outages to be scheduled. This might mean taking individual assets and/or circuits offline. The outages are part of ensuring critical 'Safety from the System', as without an outage, engineers cannot commence connection works.

## Preferred new Walpole configuration option

The physical end point substation location was not determined as part of the SOR processes, therefore both existing Walpole substation and a new substation in the vicinity of Walpole were considered as part of the siting study for the connection to a new Walpole substation. However, following work following completion of the SOR, it has been established that the proposed solution should not terminate at the existing Walpole substation. The reasons for this are that it would be impractical to extend the existing substation for the purposes of the Grimsby to Walpole project including current size, compliance with the Security and Quality of Supply Standard (SQSS) and operational complexity. Therefore, a location for a new substation will need to be identified in order to deliver the preferred ECO 6 Option.

NGET therefore proposes to take forward the following electrical configuration for the East Coast generation group:

- **Option D:** New Grimsby West to new Lincolnshire Connection substation(s), new Lincolnshire Connection substation(s) to the new Walpole substation, where the new Walpole substation is located along the existing Burwell to Walpole circuit, with EGL3 and EGL4 HVDC underground cables connecting at the new Walpole substation, together with a new 400 kV substation (Weston Marsh).

# 1. Introduction

- 1.1 In May 2023 National Grid Electricity Transmission plc (NGET) published a joint [Strategic Options Report \(SOR\)](#) for the development of the ‘North Humber to High Marnham’ and the ‘Grimsby to Walpole’ projects. That document provided an overview of the options that NGET identified and subsequently evaluated for the two projects, taking into account the likely environmental and socioeconomic effects, technical issues and costs associated with each strategic option. It identified preferred strategic options to address the identified transmission system reinforcement needs. Subsequently, NGET produced an SOR Addendum following a change in the underlying need case for the Grimsby to Walpole project. The SOR Addendum should be read alongside the SOR as it updates the conclusions.
- 1.2 The needs case for the two projects was driven by a requirement to address the connection of new generation identified within the Humber/Trent and Lincolnshire regions (Figure 1.1), as well as a need to reinforce two boundaries<sup>6</sup> within the transmission system, specifically boundaries B8 and B9. The preferred strategic options that would meet the needs case for the two areas identified within the Humber/Trent (Creyke Beck area generation group) and Lincolnshire (East Coast generation group) regions were identified as:
- To resolve Issue (a)<sup>7</sup> - Creyke Beck substation to new High Marnham substation (ECO 1) (assigned the project title of “North Humber to High Marnham”)
  - To resolve Issue (b)<sup>8</sup> - New Grimsby West to new Lincolnshire Connection substation(s), new Lincolnshire Connection substation(s) via the new Weston Marsh substation<sup>9</sup> to the new Walpole substation<sup>10</sup> (ECO 6) (assigned the project title by NGET of “Grimsby to Walpole”). This project is the focus of the present report.

---

<sup>6</sup> A “boundary”, in this context, splits the system into two parts, crossing critical circuit paths that carry power between areas and where power flow limitations may be encountered.

<sup>7</sup> See paragraph 6.1.4 of the SOR

<sup>8</sup> See paragraph 6.1.4 of the SOR

<sup>9</sup> The new Weston Marsh substation refers to a proposed new substation assumed to be at a location close to the existing 4ZM route, with the exact location subject to routing and siting.

<sup>10</sup> The new Walpole substation refers to a proposed new substation in the regional vicinity of the existing Walpole substation to provide additional connection capacity in the area. It should be noted that the new substation would not replace the existing Walpole substation and both substations will be operational following the completion of the Grimsby to Walpole project.

Figure 1.1 - Generation Groups referenced in SOR

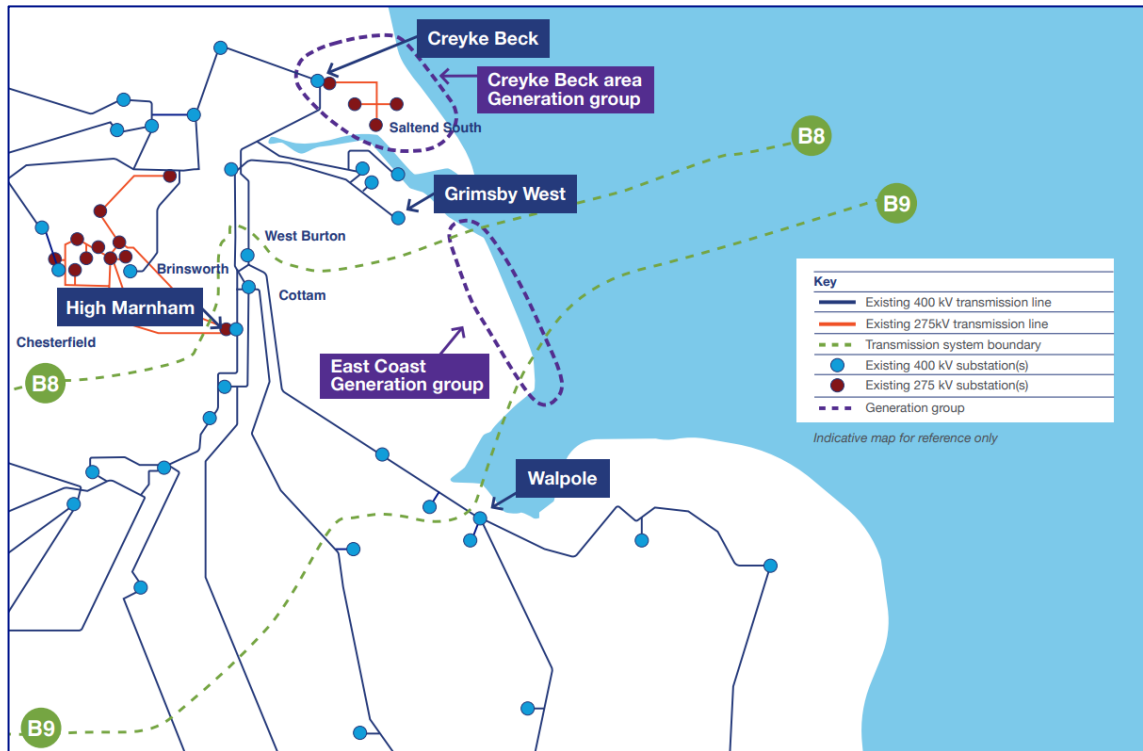

1.3 The SOR also recommended that the Eastern Green Link 3 (EGL3) and Eastern Green Link 4 (EGL4) offshore transmission circuits from Scotland should be connected south of the B9 boundary to a Main Interconnected Transmission System substation. The B9 boundary is defined as cutting the circuits between Spalding North substation and the existing Walpole substation. The preferred option included a new Walpole substation. The new Walpole substation could be sited anywhere along that bisecting circuit, south of the Spalding North circuit tee and west of Walpole, to meet the need of crossing the B9 boundary and providing required boundary capacity.

Figure 1.2 – EGL3 and EGL4 recommendation referenced in SOR

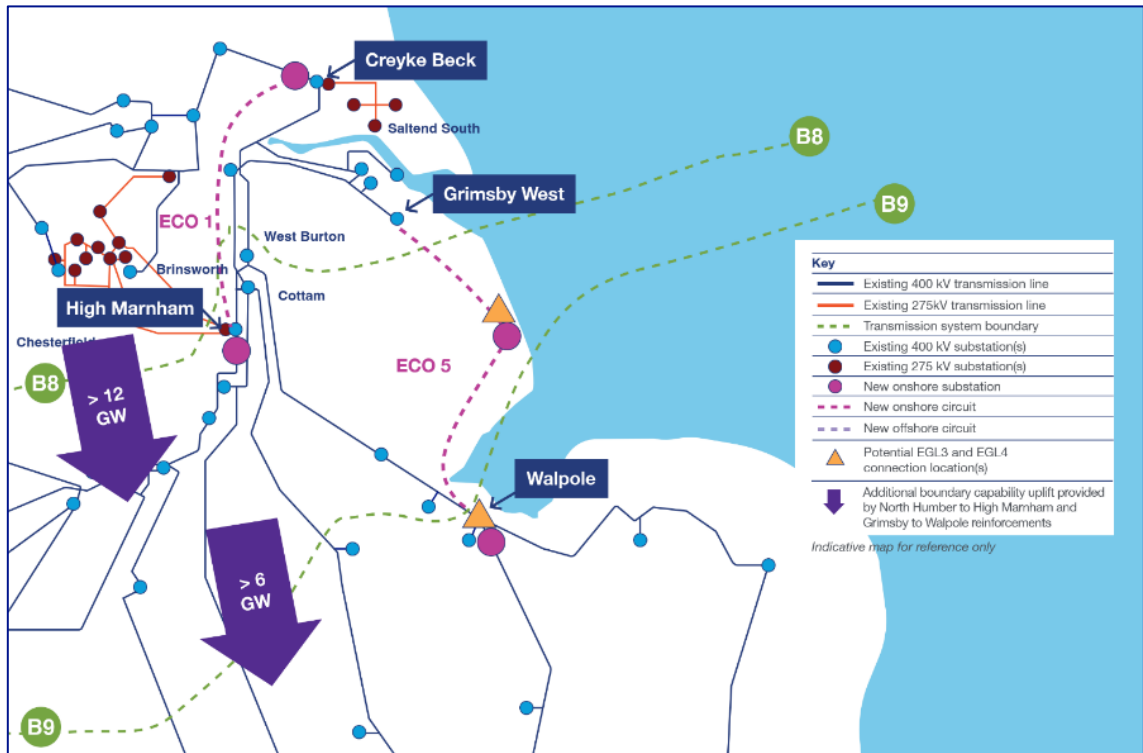

- 1.4 Since publication of the SOR, further work has been undertaken on developing and evolving the strategic option for the East Coast generation group, and in particular to evolve the design of the strategic option for works south of the B9 boundary. The consideration of strategic options is part of an iterative process in response to the interaction between a range of emerging energy projects, customer requirements, and the requirements of the transmission system. Several design factors unique to the Grimsby to Walpole project have necessitated this work, which is explained in further detail throughout this section.
- 1.5 A new Weston Marsh 400 kV substation formed part of option ECO 6, which was considered in the SOR but was discounted in favour of ECO 5. This additional substation did not directly result in an improvement in the performance of the Grimsby to Walpole project against its need case and would have resulted in additional costs and environmental impacts, and as such, was discounted at the time of the SOR's completion. Since then, additional drivers have demonstrated the need for the Weston Marsh substation, which has resulted in a need to revisit the decision to recommend ECO 5 in preference to ECO 6. The SOR Addendum discusses this in further detail.
- 1.6 The SOR, as amended by the SOR Addendum, concluded that the project should include a new Walpole substation, but the physical location for that substation was not identified in the document. The preferred strategic option selected in the SOR, as amended by the SOR Addendum, is ECO 6. This consists of a new 400 kV overhead line connection from new Grimsby West to a new Walpole substation via the Lincolnshire Connection Substation(s) and a new Weston Marsh substation. However, the SOR, as amended by the SOR Addendum, did not consider the electrical configuration in which the new Walpole substation would connect into the wider transmission system. The geographical location of the new Walpole substation is dependent on the location of the existing circuit it will connect into. Due to a large geographical spread of possible circuit options that currently converge at the existing



Walpole substation, this resulted in a large study area being defined surrounding the existing Walpole substation. Further technical and environmental appraisals were then needed to provide the additional refinement of system configurations and geographical search area required to allow routeing and siting to be commenced. That work is detailed in this Report.

- 1.7 As part of this process, the option of extending the existing Walpole substation was reviewed. This exercise was carried out to confirm that the decision to discount the extension of the existing substation remained correct given the developments in customer requirements and system reinforcements since the release of the SOR.
- 1.8 This Report is supported by Appendix A which presents study areas for each of the options considered within this report. **This Report should be read in conjunction with the SOR and SOR Addendum.**

## 2. Further Development of Configuration Options

### 2.1 Introduction

2.1.1 The SOR, as amended by the SOR Addendum, identified the preferred option for the East Coast generation group as:

- New Grimsby West to new Lincolnshire Connection substation(s), new Lincolnshire Connection substation(s) via the new Weston Marsh substation to the new Walpole substation (ECO 6) (assigned the project title by NGET of “Grimsby to Walpole”).

2.1.2 This option was identified as representing the most advantageous of the East Coast generation group options when balancing cost, technical performance and environmental and socioeconomic effects.

Figure 2.1 – ECO 6 - new Grimsby West to new Lincolnshire Connection substation(s), new Lincolnshire Connection substation(s) via the new Weston Marsh substation to the new Walpole substation

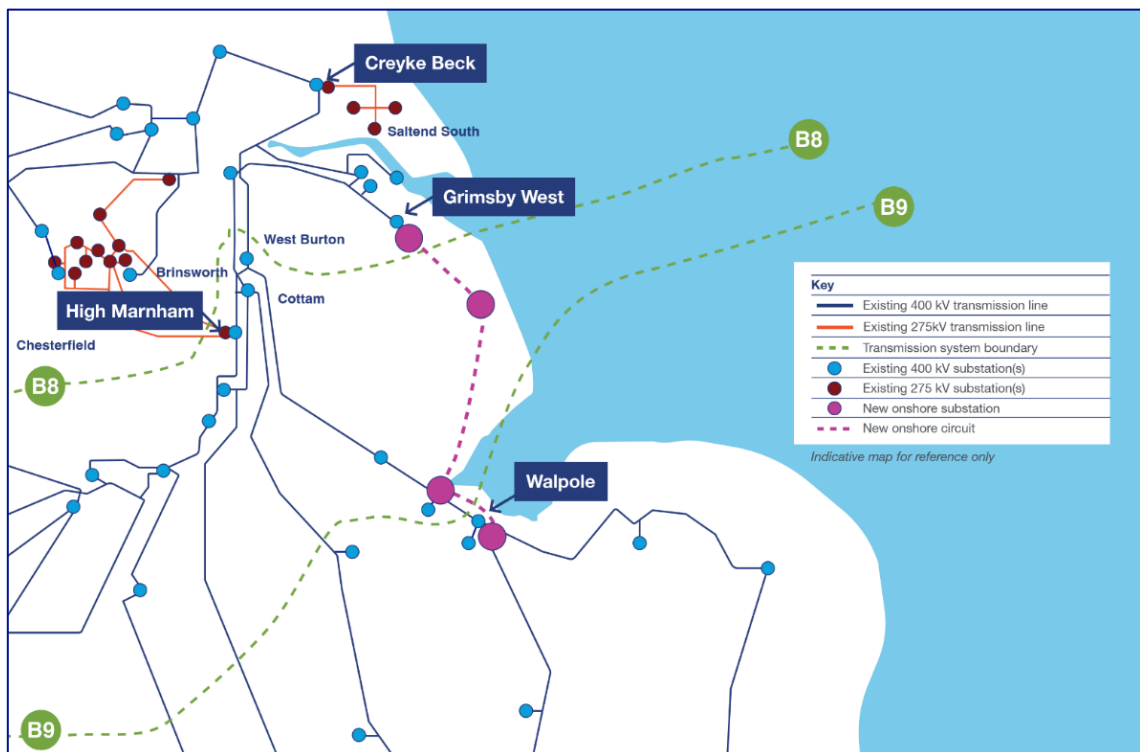

2.1.3 The B9 boundary is defined as intersecting the circuits between the Spalding Tee (where the two existing 400 kV overhead lines, 4ZM and 2WS, meet) and Walpole on the 4ZM route, and that the new Walpole substation could be sited anywhere along the bisecting circuit, south of the Spalding North circuit tee and Walpole to meet the need of crossing the B9 boundary and providing the required boundary capacity.

- 2.1.4 NGET has undertaken further work to identify the preferred configuration option for the location of the new Walpole substation. As part of this process, we reviewed the assumption that it would be a new substation and not an extension of the existing substation to ensure this remained correct. This report deals with the locations on the electricity network and resultant changes to its configuration that are appropriate for such a new Walpole substation.
- 2.1.5 Consideration has also been given to interaction between the Grimsby to Walpole project and the EGL3 and EGL4 projects, acknowledging that the EGL3 and EGL4 projects are subject to their own full appraisal of strategic options.

## 2.2 Option Development

### Long list of options

- 2.2.1 A long list of options was identified. The northern elements of the project are common across all options – as far as the vicinity of Weston Marsh. The options included consideration of the need for the inclusion of Weston Marsh substation (as identified in the SOR Addendum). The long list of options was subsequently passed through a technical filter to exclude options that did not meet the needs case outlined by the SOR (as supplemented by the SOR Addendum) or were clearly less effective than alternative options with respect to providing capability across the B9 boundary.
- 2.2.2 Options A & B were discounted at this stage.
- 2.2.3 Option A consisted of a new Grimsby West to new Lincolnshire Connection substation(s), new Lincolnshire Connection substation(s) to a new 400 kV substation (Weston Marsh). A new OHL double circuit connecting into the WALP4 to BURW4<sup>11</sup> circuit from the new Weston Marsh substation. The EGL3 and EGL4 HVDC underground cables connect into the Weston Marsh substation. As the EGL3 and EGL4 HVDC underground cables connect into Weston Marsh, above the B9 boundary, this therefore does not satisfy the needs case outlined in the SOR, as amended by the SOR Addendum. As such, Option A was discounted.
- 2.2.4 Option B consisted of a new Grimsby West to new Lincolnshire Connection substation(s), new Lincolnshire Connection substation(s) to a new 400 kV substation south of the Spalding Tee (above the B9 boundary), situated along the existing 4ZM 400 kV OHL. A new OHL double circuit connecting into the WALP4 to BURW4 circuit from the new substation located along the existing 4ZM 400 kV OHL. The EGL3 and EGL4 HVDC underground cables connected into this substation. As the EGL3 and EGL4 HVDC underground cables connect into the substation above the B9 boundary, this therefore does not satisfy the needs case outlined in the SOR, as amended by the SOR Addendum. As such, Option B was also discounted.

### Existing Walpole substation extension

- 2.2.5 During the identification of a long list of options, the option of extending the existing Walpole substation was considered. Due to a number of technical and operational constraints for the purposes of the Grimsby to Walpole project, including an increase in fault levels and the volume of customer applications at Walpole substation which was

---

<sup>11</sup> The existing 400 kV overhead line circuit from the existing Walpole substation to the existing Burwell Main substation

considered likely to trigger a second substation. It was therefore concluded that the decision to discount the extension of the existing substation remains valid.

## Study areas

- 2.2.6 As part of the option development, appropriate study areas (generally 10 km wide) were drafted for each of the short-listed options to reflect potential Grimsby to Walpole southern end point locations along either the Burwell to Walpole circuit or Norwich Main to Walpole circuit. The study areas for the four short-listed options are shown in Appendix A. For each short-listed option, study areas were developed to extend along the Burwell to Walpole circuit (Options C, D and E) or Norwich Main to Walpole circuit (Option F). The furthest extent of the study area for each option was limited to a distance beyond which the development of new infrastructure would be expected to be ruled out based on additional environmental constraints or offering a less effective electrical configuration. The study areas are labelled from '1' to '3', with '1' representing the shortest, and '3' representing the furthest extent of each study area.
- 2.2.7 The study areas allow consideration of the development of new infrastructure within a study area located below the B9 boundary and extending at different distances along the Burwell to Walpole circuit (Options C, D and E) or Norwich Main to Walpole circuit (Option F). As the northern elements comprising new Grimsby West to new Lincolnshire Connection substation(s) are the same for all options, a northern cut-off point located in the vicinity of Boston was agreed for the purpose of refining the study areas to a sensible and proportionate extent.

## Weston Marsh substation

- 2.2.8 As stated in the SOR Addendum and Section 1 of this Report, following the confirmation of customer connection drivers at Weston Marsh, the substation is now required. As such, to ensure that options have been compared fairly, the assessment process considers Weston Marsh substation within all option appraisals. The substation is not shown in the network configuration diagrams included within the appraisal of Options C, E and F. This is due to the new overhead line infrastructure of the Grimsby to Walpole project within these options not directly interfacing with the Weston Marsh substation.

## Short-list of options

- 2.2.9 A short-list of four options that would meet the needs case of the East Coast generation group was identified to be taken forward for options appraisal. These are listed below:
- **Option C:** New Grimsby West to new Lincolnshire Connection substation(s), new Lincolnshire Connection substation(s) to the new Walpole substation, where the new Walpole substation is located along the existing Burwell to Walpole circuit (4ZM), with EGL3 and EGL4 HVDC underground cables connecting at the new Walpole substation. This option would require a duck under of the existing 4ZM overhead line.
  - **Option D:** New Grimsby West to new Lincolnshire Connection substation(s), new Lincolnshire Connection substation(s) to the new Walpole substation, where the new Walpole substation is located along the Burwell to Walpole circuit, with EGL3 and EGL4 HVDC underground cables connecting at the new Walpole substation, together with a second new 400 kV substation (Weston Marsh). The Grimsby to Walpole overhead line would connect into Weston Marsh substation and continue to the new Walpole substation.

- **Option E:** New Grimsby West to new Lincolnshire Connection substation(s), new Lincolnshire Connection substation(s) to existing Walpole. Grimsby to Walpole overhead line terminates at existing Walpole (using bays vacated by a reconfiguration of the substation). The new Walpole substation is located along the Burwell to Walpole circuit, with EGL3 and EGL4 HVDC underground cables connecting at the new Walpole substation. The existing Bicker Fen-Walpole and Bicker Fen-Spalding North-Walpole circuits are diverted into the new Walpole substation.
- **Option F:** New Grimsby West to new Lincolnshire Connection substation(s), new Lincolnshire Connection substation(s) to the new Walpole substation, where the new Walpole substation is located along the Norwich Main to Walpole circuit, with EGL3 and EGL4 HVDC underground cables connecting at the new Walpole substation.

2.2.10 For the purpose of the appraisal, a number of assumptions were made relating to the interactivity between the Grimsby to Walpole project and the EGL3 and EGL4 projects, as follows:

- Two converter stations would need to be located within 5 km of the new Walpole substation for EGL3 and EGL4 to enable connection of the HVDC links into the wider AC network. There are benefits to having the converter stations closely located to the substation, as both converter stations are required to be connected to the substation. Reducing the distance between the substation and the converter stations therefore reduces the length of any required connection infrastructure between them, thereby minimising impact on local communities and the environment. It also allows a degree of potential co-location benefits from a landscape and visual point of view.
- Both EGL3 and EGL4 projects would make landfall at a location on the Lincolnshire coast.

2.2.11 Since the publication of the SOR, the required number of bays (points of connection for circuits, customers or other operational equipment within the substation) for each substation has changed. This is primarily due to the evolving generation needs in the region. To reflect the most accurate information, the costings for new Weston Marsh and new Walpole substation have been updated accordingly to reflect the revised number of bays. The number of bays for each substation is stated within each option appraisal section. The costs and scope reflect the current status at the time of concluding this report and will be subject to ongoing review.

## 3. Options Assessment Process

- 3.1 Each of the shortlisted options have been appraised in accordance with NGET's document 'Our Approach to Consenting'<sup>12</sup>. All options have been evaluated in respect of environmental, socioeconomic, technical, and capital and lifetime costs assessments-.
- 3.2 The assessment process considers the following areas:
- Environmental assessment topics which consider whether there are environmental constraints or issues of sufficient importance to influence decision making at a strategic level, having particular regard for internationally or nationally important receptors.
  - Socioeconomic topics which consider whether there are socioeconomic constraints or issues of sufficient importance to influence decision-making at a strategic level, having particular regard for internationally or nationally important receptors.
  - Consideration of technical benefits, including whether the option provides the required capacity to meet the needs case, whether the option has particular system benefits over alternatives, and whether the option introduces any system complexity that would cause system operability issues or compromise system resilience.
  - Capital and lifetime cost of the option based on the high-level scope of works defined for each option. Final project costs for any solution taken forward following detailed design, consenting and risk mitigation will be in excess of any high-level appraisal cost. However, all options would incur these increases proportional to initial estimate in the development of a detailed solution. This methodology ensures that all options for appraisal proposes are compared on a like for like basis. Secondary costs such as likely requirements for localised underground cabling<sup>13</sup>, associated transitional equipment, line swap overs<sup>14</sup> or existing overhead line reconfigurations have also been considered within the assessment process.
- 3.3 In this appraisal, a detailed analysis of outage requirement impacts on the delivery programme cannot be undertaken. Some high-level consideration has however been given to outage complexity and construction requirements in the options appraisal so that options which present significantly more programme risk than others due to outage requirements are assessed accordingly.
- 3.4 As detailed in Section 2, various study areas were identified to reflect potential end point locations. Study areas were identified and labelled from '1' to '3'. Potential circuit lengths were derived by taking a straight line distance between the points (assuming

---

<sup>12</sup> Our Approach to Consenting, National Grid (April 2022) <https://www.nationalgrid.com/electricity-transmission/document/142336/download>

<sup>13</sup> An insulated conductor carrying electric current designed for underground installation.

<sup>14</sup> Where the design of existing pylons is compatible and the direction of power flows across the electricity system allow it, a 'line swap over' can be considered. This is done through the removal of a length of the existing overhead line, allowing the two newly formed 'ends' of existing overhead line to be connected to two lengths of new route located on different sides of the existing line. The two resultant routes would then comprise lengths of both newly built and existing overhead line, but in a different electrical configuration.

start point at the Spalding Tee) and adding 20% to accommodate potential route deviations and adjustments in substation siting that might be required if the option proceeds forward to more detailed routing and siting.

- 3.5 The initial option lengths identified for each of the study areas do not define route corridors, and environmental appraisal is provided over a wide study area between points of connection. Any routes for circuit technologies to take would be subject to detailed routing and siting for any configuration option taken forward as a preferred option(s).

# 4. Appraisal of Options

## 4.1 Introduction

- 4.1.1 For the purposes of the appraisal, the northern elements of all short-listed options north of the B9 boundary are assumed to be common to all short-listed options. As a result, the appraisal of options focussed only on those elements in the vicinity of, and south of, the B9 boundary. This includes an area surrounding the Spalding Tee which is the likely siting area for the Weston Marsh substation.
- 4.1.2 The study areas labelled from '1' to '3' represent a sliding end point; '1' are shorter and would likely require less overhead line infrastructure compared with '2' or '3' which route further south respectively. The methodology of a sliding end point was used to provide flexibility in relation to study areas; if a shorter length presented constraints, then '2' or '3' could be explored. The study areas are presented in Appendix A.
- 4.1.3 From an environmental, socioeconomic, technical, and cost perspective it was identified that study areas which would reduce the required length of the Grimsby to Walpole overhead circuits, and EGL3 and EGL4 HVDC underground cables (from an assumed Lincolnshire landfall) would generally be preferred as they would reduce overall required infrastructure lengths and are therefore likely to reduce the scale of associated environmental impacts, technical constraints, and costs. Hence study areas labelled from '1' which are shorter were identified as generally being preferred, compared to study areas '2' or '3'. As such, this section presents the findings of the options appraisal based on study area '1' only for each option.
- 4.1.4 As noted in Section 2, new Weston Marsh substation is required in all scenarios relating to the short-listed options. As such, to ensure that options have been compared fairly, the assessment process considers Weston Marsh substation within all option appraisals. This includes an assessment of environmental, socioeconomic, technical, cost factors.

## 4.2 Option C

- 4.2.1 Option C involves the construction of a new transmission circuit connection between a new Grimsby West substation to new Lincolnshire Connection substation(s), and from new Lincolnshire Connection substation(s) to the new Walpole substation, where the new Walpole substation is located along the Burwell to Walpole circuit. EGL3 and EGL4 HVDC underground cables would connect at the new Walpole substation. This option would require a duck under of the existing 4ZM overhead line and additional Sealing End Compound infrastructure each side of the HVDC undergrounding. The study areas are presented in Appendix A, Figure A, Figure B and Figure C.



Figure 4.1 - Option C (acronym terms stated in Appendix B)

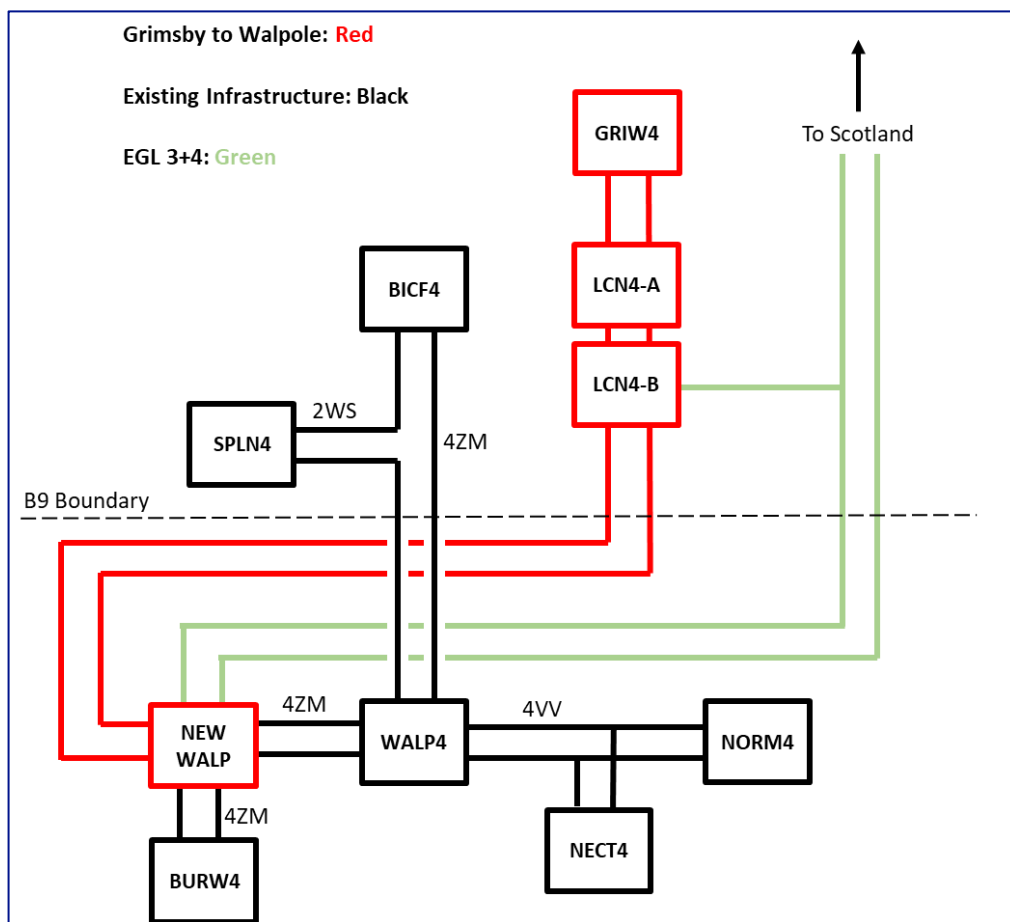

Figure 4. 1

4.2.2 Overall, Option C is relatively constrained in relation to both ecological, landscape and visual considerations. Whilst The Wash Ramsar Site, Site of Special Scientific Interest (SSSI), Special Protection Area (SPA), Important Bird Area (IBA) and National Nature Reserve and The Wash and North Norfolk Coast IBA and SAC are avoidable, there is the potential for adverse effects on the interest features (both habitats and species), for which a number of these sites are designated. If this option were to be progressed, NGET would need to demonstrate that the development would not affect the integrity of designated sites. Based on the information available at this stage of the project's development, it is considered that Option C could be progressed to the extent that it would not affect the integrity of designated ecological sites (once appropriate mitigation was taken into account). There is potential for adverse landscape and visual impacts due to the introduction of a new overhead line, new Sealing End Compound infrastructure to facilitate an underground cable (UGC) to pass the 4ZM, a new Walpole substation and two new EGL converter stations. The proposed overhead line, HVDC underground cable, substation and converter stations would need to be routed and sited to avoid settlements, visitor attractions, and long-distance open views (particularly from the high ground) as far as possible. Consideration would need to be given to the potential benefits of running the proposed overall line in close parallel to the existing 4ZM 400 kV overhead line at the routing and siting stage. Other key environmental and socioeconomic constraints are considered to be less influential with the potential to mitigate adverse impacts through careful consideration of routing and siting and the use of appropriate technologies.

- 4.2.3 Alongside the environmental and socioeconomic appraisal of the option a technical appraisal identified the following:
- The assumed overhead line length is approximately 31 km and the assumed HVDC cable route for the EGL projects is approximately 95 km.
  - A 400 kV overhead line crossing will be required.
  - Medium outage complexity - Bicker Fen-Walpole and Bicker Fen-Spalding North-Walpole circuits outages are required to facilitate the 4ZM duck-under. An outage is required on the Burwell-Walpole circuits to facilitate the new turn-in of the circuits to the new Walpole substation.
  - In this configuration, the transmission system in the region is susceptible to certain circuit faults which could severely limit the ability of the network to export generation from the East Coast Generation Group to demand centres in the south. As a result, this option is less preferred from a network resilience point of view.
- 4.2.4 A cost evaluation of the following four technologies for onshore options evaluation has been undertaken.
- 400 kV alternating current (AC) overhead line
  - 400 kV AC underground cable
  - 400 kV AC gas insulated line (GIL)
  - 525 kV HVDC underground cable and converter stations
- 4.2.5 Option C requires the following transmission works to satisfy the requirements of the Grimsby to Walpole needs case, network compliance, customer connections and SQSS compliance.
- **New circuit requirements**
    - AC connection options use double circuits (2 x 400 kV AC circuits) with a total capacity of up to 6930 mega volt amperes (MVA) or;
    - HVDC connection options use 525 kV 2 GW voltage source links, which would require a converter station at each end. To come close to matching the AC hi-capacity circuits of 6930 MVA, the option would require at least three 2 GW HVDC connections between the Tee point and the new Walpole substation, and would require three converter stations at each substation.
  - **Substation Works**
    - 28 bay new Walpole 400 kV substation to accommodate required new circuits.
    - 27 bay new Weston Marsh 400 kV to accommodate customer connection drivers
- 4.2.6 Table 4.1 below sets out the capital costs for Option C considering substation works and each technology option.

Table 4.1 – Option C capital cost for each technology option

Item	Need	Capital cost
------	------	--------------

Substation works	Facilitate generation and connect new circuits	£267.3m			
<b>New circuits</b>		<b>AC overhead line</b>	<b>AC cable</b>	<b>AC GIL</b>	<b>HVDC</b>
New circuit 31 km	New circuit across B9	£123.4m	£1,307.5m	£1,341.1m	£1,890.5m
<b>Total capital cost</b>		<b>£390.7m</b>	<b>£1,574.8m</b>	<b>£1,608.4m</b>	<b>£2,157.8m</b>

4.2.7 Table 4.2 below sets out the lifetime cost for the new circuit options, the lifetime costs are different for each circuit technology and are included as a differentiator between technologies. These costs are calculated using the methodology described in “Strategic options technical appendix 2020/2021 price base” within Appendix D of the SOR.

Table 4.2 – Option C lifetime cost for each technology option

	<b>AC overhead line</b>	<b>AC cable</b>	<b>AC GIL</b>	<b>HVDC</b>
<b>Capital cost of new circuits</b>	£123.4m	£1,307.5m	£1,341.1m	£1,890.5m
<b>NPV of cost of losses over 40 years</b>	£87m	£54.4m	£40.4m	£471.2m
<b>NPV of operation &amp; maintenance costs over 40 years</b>	£1.8m	£5.6m	£1.8m	£171.7m
<b>Lifetime cost of new circuits</b>	<b>£212m</b>	<b>£1,368m</b>	<b>£1,383m</b>	<b>£2,533m</b>

4.2.8 Secondary costs for Option C are comprised of the infrastructure required for the crossing of the existing 4ZM overhead line. It is anticipated that this will be by way of an underground cable (UGC) solution. A high level of analysis of the required infrastructure indicated an approximate total cost of £50m.

4.2.9 From the environmental and technical appraisal considered, alongside capital and circuit lifetime costs, our starting presumption for further development of this option, should it be selected, would be for a majority AC overhead line connection. This includes the consideration of the fact that the technology recommended for remainder of the Grimsby to Walpole project between Grimsby West and the Spalding Tee is also primarily AC overhead line. Any alternative technology would not only significantly increase costs but would require additional infrastructure to facilitate the interface between two different technology types. For example, switching to three HVDC 2 GW

links would require 6 additional converter stations in total, significantly increasing visual impact and complexity in routing and siting. This is a consideration for all options.

4.2.10 In summary, Option C is a 31 km primarily overhead line connection between the Spalding Tee and the new Walpole substation, with the new Walpole substation located along the Burwell to Walpole circuit and assuming the EGL3 and EGL4 HVDC underground cables would connect at the new Walpole substation.

### 4.3 Option D

4.3.1 Option D involves a new transmission circuit connection between the Spalding Tee and the new Walpole substation, with the new Walpole substation located along the Burwell to Walpole circuit assuming EGL3 and EGL4 HVDC underground cables would connect at the new Walpole substation, and a second new 400 kV substation (Weston Marsh). The Grimsby to Walpole overhead line would connect into Weston Marsh and continue to the new Walpole substation. The study areas are presented in Appendix A, Figure D, Figure E and Figure F.

Figure 4.2 - Option D (acronym terms stated in Appendix B)

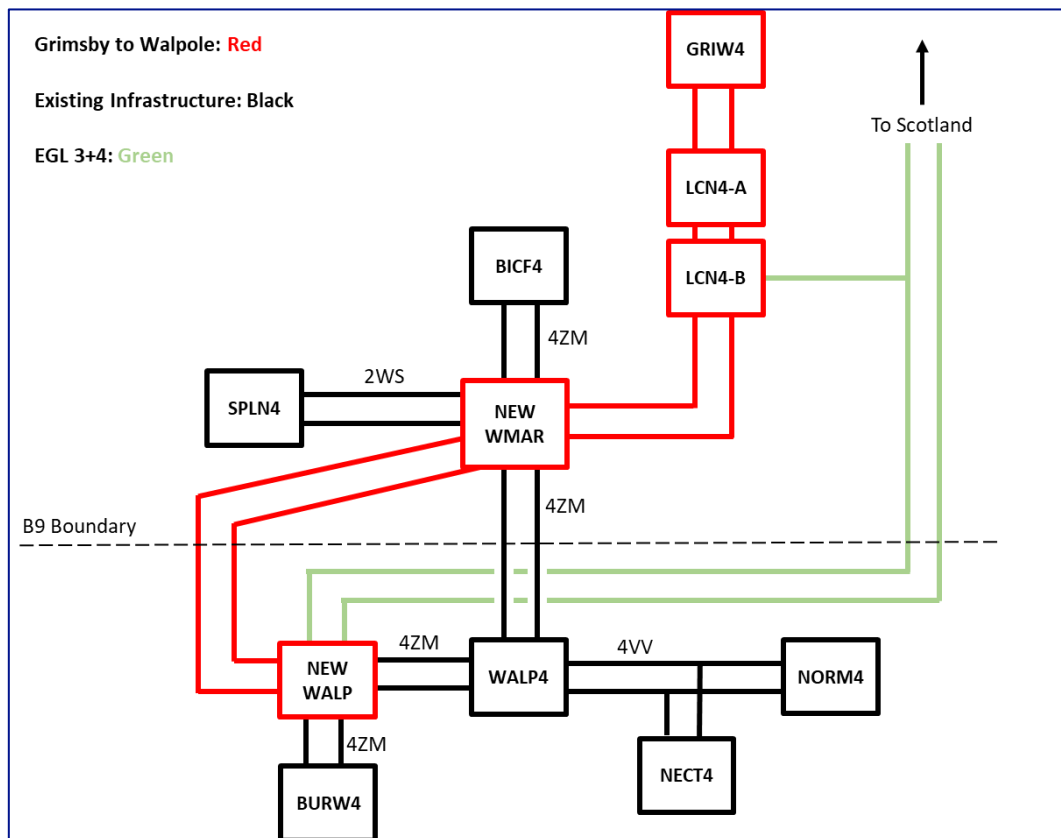

Figure 4. 2

4.3.2 The key environmental and socioeconomic constraints affecting Option D would be as reported for Option C above. However, Option D requires the associated line entry

reconfigurations (such as terminal towers<sup>15</sup>) in the vicinity of the new Weston Marsh substation to accommodate turning in existing and new circuits into the substation, with the associated landscape and visual impacts. Option D would however exclude the need for a duck under of the existing 4ZM overhead line, and therefore the associated Sealing End Compound infrastructure required to facilitate this crossing would not be required in Option D.

4.3.3 Alongside the environmental and socioeconomic appraisal of the option a technical appraisal identified the following:

- Assumed overhead line length is approximately 31 km. Assumed HVDC cable route for the EGL 3 and 4 projects is approximately 95 km.
- Line entry reconfigurations required to three double circuits at the Spalding Tee.
- High outage complexity – Bicker Fen-Walpole and Bicker Fen-Spalding North-Walpole circuits outage required to facilitate turn-in to the new Weston Marsh substation, outage required on the Burwell-Walpole circuits to facilitate new turn-in to the new Walpole substation.
- In this configuration, the additional network node at Weston Marsh means the transmission system in the region is less susceptible to the circuit faults mentioned for Option C causing significant limitations to the network capacity available to export generation from the East Coast Generation Group to demand centres in the south. As a result, this option is more preferred from a network resilience point of view.

4.3.4 A cost evaluation of the following four technologies for onshore options evaluation has been undertaken.

- 400 kV alternating current (AC) overhead line
- 400 kV AC underground cable
- 400 kV AC gas insulated line (GIL)
- 525 kV HVDC underground cable and converter stations

4.3.5 Option D requires the following transmission works to satisfy the requirements of the Grimsby to Walpole needs case, network compliance, customer connections and SQSS compliance.

- **New circuit requirements**

- AC connection options use double circuits (2 x 400 kV AC circuits) with a total capacity of up to 6930 mega volt amperes (MVA) or;
- HVDC connection options use 525 kV 2 GW voltage source links, which would require a converter station at each end. To come close to matching the AC hi-capacity circuits of 6930 MVA, the option would require at least three 2 GW HVDC connections between the Tee point and the new Walpole substation, and would require three converter stations at each substation.

- **Substation Works**

- 28 bay new Walpole 400 kV substation to accommodate required new circuits.

---

<sup>15</sup> A terminal tower is used when the overhead power line terminates, and is connected to substation equipment, or transitions to underground cable

- 27 bay new Weston Marsh 400 kV to accommodate customer connection drivers

4.3.6 Table 4.3 below sets out the capital costs for Option D considering substation works and each technology option.

**Table 4.3 – Option D capital cost for each technology option**

Item	Need	Capital cost			
Substation works	Facilitate generation and connect new circuits	£267.3m			
New circuits		AC overhead line	AC cable	AC GIL	HVDC
New circuit 31 km	New circuit across B9	£123.4m	£1,307.5m	£1,341.1m	£1,890.5m
<b>Total capital cost</b>		<b>£390.7m</b>	<b>£1,574.8m</b>	<b>£1,608.4m</b>	<b>£2,157.8m</b>

4.3.7 Table 4.4 below sets out the lifetime cost for the new circuit options, the lifetime costs are different for each circuit technology and are included as a differentiator between technologies. These costs are calculated using the methodology described in “Strategic options technical appendix 2020/2021 price base” within Appendix D of the SOR.

**Table 4.4 – Option D lifetime cost for each technology option**

	AC overhead line	AC cable	AC GIL	HVDC
<b>Capital cost of new circuits</b>	£123.4m	£1,307.5m	£1,341.1m	£1,890.5m
<b>NPV of cost of losses over 40 years</b>	£87m	£54.4m	£40.4m	£471.2m
<b>NPV of operation &amp; maintenance costs over 40 years</b>	£1.8m	£5.6m	£1.8m	£171.7m
<b>Lifetime cost of new circuits</b>	<b>£212m</b>	<b>£1,368m</b>	<b>£1,383m</b>	<b>£2,533m</b>

- 4.3.8 The additional secondary costs for Option D are comprised of the line entry modifications required for the existing overhead lines at the Spalding Tee, costing approximately £7.5m, and the additional terminal towers and line entries required on the Grimsby to Walpole overhead line, costing approximately £5m.
- 4.3.9 From the environmental and technical appraisals considered, alongside overall costs, our starting presumption for further development of this option should it be selected, would be for a majority AC overhead line connection.
- 4.3.10 In summary, Option D is a 31 km primarily AC overhead line connection between the Spalding Tee and the new Walpole substation, with the new Walpole substation located along the Burwell to Walpole circuit assuming EGL3 and EGL4 HVDC underground cables would connect at the new Walpole substation, and a new 400 kV substation (Weston Marsh). The Grimsby to Walpole overhead line would connect into Weston Marsh substation and continue to the new Walpole substation.

## 4.4 Option E

- 4.4.1 Option E involves the construction of a new transmission circuit connection between a new Grimsby West to new Lincolnshire Connection substation(s), new Lincolnshire Connection substation(s) to the existing Walpole substation (using bays vacated by a reconfiguration of the existing 4ZM circuits). The new Walpole substation is located along the Burwell to Walpole circuit, with EGL3 and EGL4 HVDC underground cables connecting at the new Walpole substation. The existing Bicker Fen-Walpole and Bicker Fen-Spalding North-Walpole circuits are diverted into the new Walpole substation. The study areas are presented in Appendix A, Figure A, Figure B and Figure C.

Figure 4.3 - Option E (acronym terms stated in Appendix B)

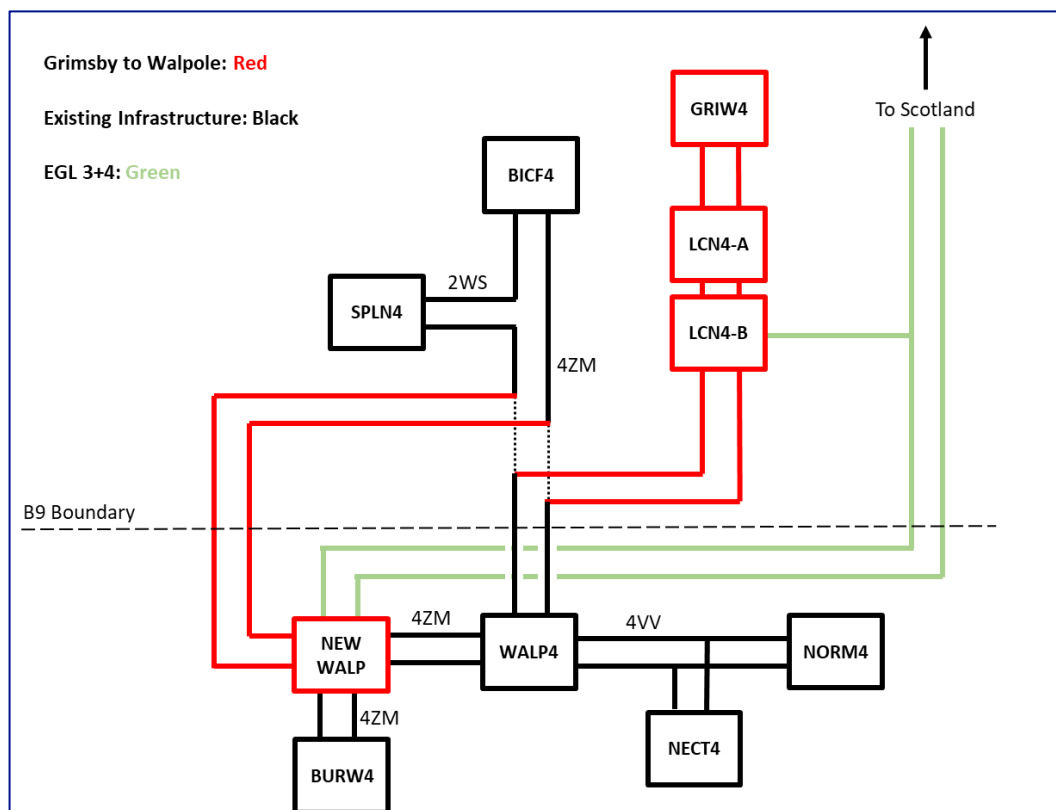

Figure 4. 3

- 4.4.2 The key environmental and socioeconomic constraints affecting Option E would be as reported for Option C above. However, Option E excludes the need for a duck under of the existing 4ZM overhead line, instead likely requiring a line swap, and therefore the associated Sealing End Compound infrastructure required to facilitate this crossing would not be required in Option E.
- 4.4.3 Alongside the environmental and socioeconomic appraisal of the option a technical appraisal identified the following:
- Assumed overhead line length is approximately 31 km. Assumed HVDC cable route for the EGL 3 and 4 projects is approximately 95 km.
  - High outage complexity - To deliver this option, the existing 4ZM tower route into Walpole would be utilised to connect in the new Grimsby to Walpole project. The 4ZM line would then be diverted and connect into the new Walpole substation. This adds extra complexity for outage planning as the Bicker Fen-Walpole and Bicker Fen Spalding North-Walpole circuits require outages to facilitate a tower swap between new and existing circuits and additional outages are required on the Burwell to Walpole circuits to facilitate new turn-in to the new Walpole substation.
  - In this configuration, the transmission system in the region is susceptible to certain circuit faults which could severely limit the ability of the network to export generation from the East Coast Generation Group to demand centres in the south. As a result, this option is less preferred from a network resilience point of view.



- 4.4.4 A cost evaluation of the following four technologies for onshore options evaluation has been undertaken.
- 400 kV alternating current (AC) overhead line
  - 400 kV AC underground cable
  - 400 kV AC gas insulated line (GIL)
  - 525 kV HVDC underground cable and converter stations
- 4.4.5 Option E requires the following transmission works to satisfy the requirements of the Grimsby to Walpole needs case, network compliance, customer connections and SQSS compliance.
- **New circuit requirements**
    - AC connection options use double circuits (2 x 400 kV AC circuits) with a total capacity of up to 6930 mega volt amperes (MVA) or;
    - HVDC connection options use 525 kV 2 GW voltage source links, which would require a converter station at each end. To come close to matching the AC hi-capacity circuits of 6930 MVA, the option would require at least three 2 GW HVDC connections between the Tee point and the new Walpole substation, and would require three converter stations at each substation.
  - **Substation Works**
    - 28 bay new Walpole 400 kV substation to accommodate required new circuits.
    - 27 bay new Weston Marsh 400 kV to accommodate customer connection drivers
- 4.4.6 Table 4.5 below sets out the capital costs for Option E considering substation works and each technology option.

**Table 4.5 – Option E capital cost for each technology option**

Item	Need	Capital cost			
Substation works	Facilitate generation and connect new circuits	£267.3m			
<b>New circuits</b>		<b>AC overhead line</b>	<b>AC cable</b>	<b>AC GIL</b>	<b>HVDC</b>
New circuit 31 km	New circuit across B9	£123.4m	£1,307.5m	£1,341.1m	£1,890.5m
<b>Total capital cost</b>		<b>£390.7m</b>	<b>£1,574.8m</b>	<b>£1,608.4m</b>	<b>£2,157.8m</b>

4.4.7 Table 4.6 below sets out the lifetime cost for the new circuit options, the lifetime costs are different for each circuit technology and are included as a differentiator between technologies. These costs are calculated using the methodology described in “Strategic options technical appendix 2020/2021 price base” in Appendix D of the SOR.

**Table 4.6 – Option E lifetime cost for each technology option**

	<b>AC overhead line</b>	<b>AC cable</b>	<b>AC GIL</b>	<b>HVDC</b>
<b>Capital cost of new circuits</b>	£123.4m	£1,307.5m	£1,341.1m	£1,890.5m
<b>NPV of cost of losses over 40 years</b>	£87m	£54.4m	£40.4m	£471.2m
<b>NPV of operation &amp; maintenance costs over 40 years</b>	£1.8m	£5.6m	£1.8m	£171.7m
<b>Lifetime cost of new circuits</b>	<b>£212m</b>	<b>£1,368m</b>	<b>£1,383m</b>	<b>£2,533m</b>

4.4.8 Secondary costs for Option E are comprised of the infrastructure works required for the line swap over between the new overhead line route and the existing 4ZM overhead line. A high-level analysis of the required infrastructure indicated an approximate total cost of £2.5m in addition to the costs in Table 4.6.

4.4.9 From the environmental and technical appraisals considered, alongside overall costs, our starting presumption for further development of this option should it be selected, would be for a majority AC overhead line connection.

4.4.10 In summary, Option E is a 31 km primarily AC overhead line connection between a new Grimsby West substation to the new Lincolnshire Connection substation(s), and from the new Lincolnshire Connection substation(s) to existing Walpole. The new Walpole substation is located along the Burwell to Walpole circuit, with EGL3 and EGL4 HVDC underground cables connecting at the new Walpole substation.

## 4.5 Option F

4.5.1 Option F involves the construction of a new transmission circuit connection between a new Grimsby West substation to new Lincolnshire Connection substation(s), and from new Lincolnshire Connection substation(s) to the new Walpole substation, where the new Walpole substation is located along the existing Walpole to Norwich Main overhead line route (4VV), with the EGL3 and EGL4 HVDC underground cables connecting at the new Walpole substation. The study areas are presented in Appendix A, Figure G, Figure H and Figure I.

Figure 4.4 - Option F (acronym terms stated in Appendix B)

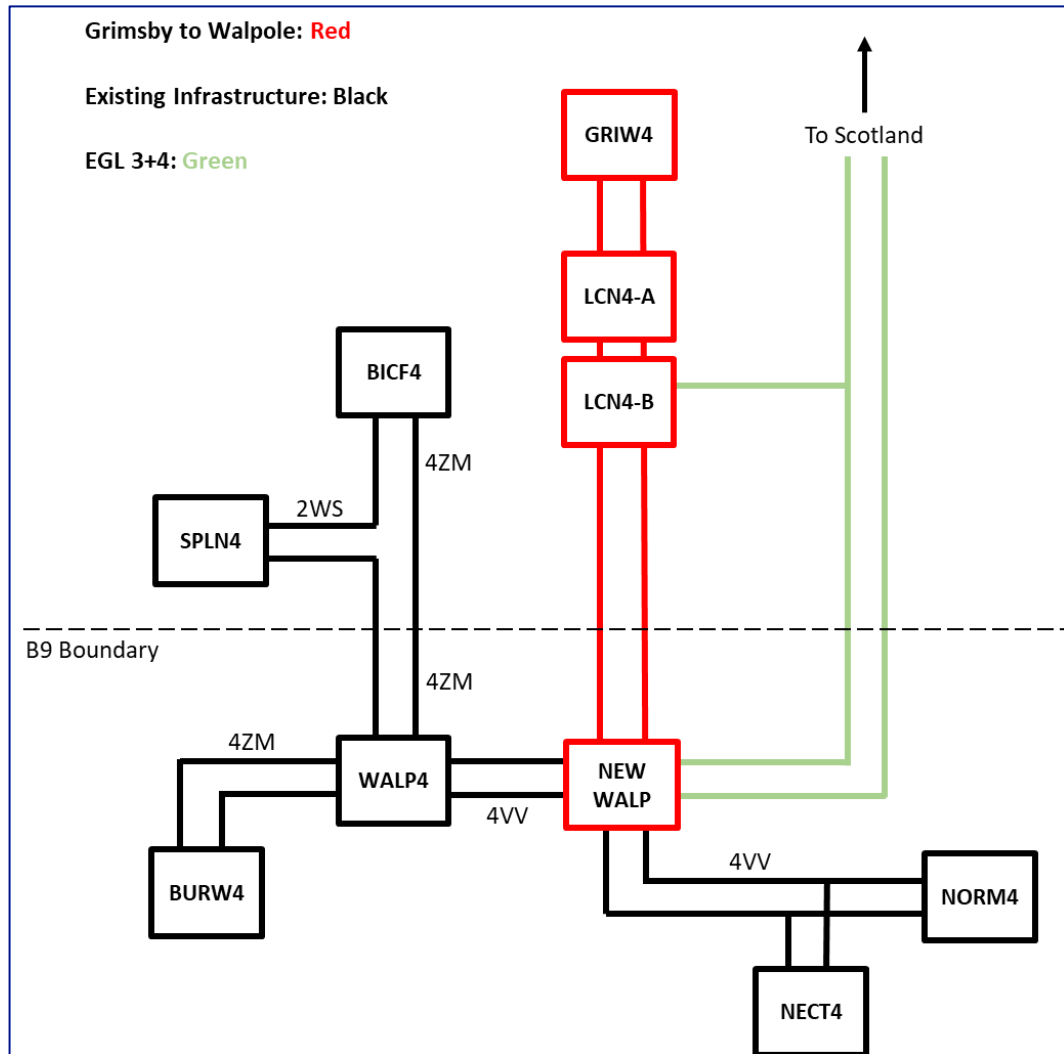

Figure 4. 4

- 4.5.2 The key environmental and socioeconomic constraints affecting Option F would be similar to those reported for Options C, D and E above, however Option F may be more likely to have adverse environmental effects which cannot be mitigated compared with all other options due to closer proximity to designated sites along the coast including The Wash SPA, Ramsar, IBA and SSSI designations.
- 4.5.3 Option F avoids the need for any direct interface with the existing 4ZM overhead line, and therefore Cable Sealing End Compound and line swap-over infrastructure would not be required in Option F.
- 4.5.4 Alongside the environmental and socioeconomic appraisal of the option a technical appraisal identified the following:
- Assumed overhead line length is approximately 32 km. Assumed HVDC cable route for the EGL 3 and 4 projects is approximately 115 km.
  - Low outage complexity - outage required only on the Walpole to Norwich Main circuits to facilitate new turn-in to the new Walpole substation.

- In this configuration, the design does not lend itself to optimal power transfer across the transmission system. As a result, this option is less preferred from a network resilience point of view.
- Situating the new Walpole substation on the Walpole to Norwich Main circuits results in poorer technical performance with respect to increasing the power transfer capability of the transmission system across B9.

4.5.5 A cost evaluation of the following four technologies for onshore options evaluation has been undertaken.

- 400 kV alternating current (AC) overhead line
- 400 kV AC underground cable
- 400 kV AC gas insulated line (GIL)
- 525 kV HVDC underground cable and converter stations

4.5.6 Option F requires the following transmission works to satisfy the requirements of the Grimsby to Walpole needs case, network compliance, customer connections and SQSS compliance.

- **New circuit requirements**

- AC connection options use double circuits (2 x 400 kV AC circuits) with a total capacity of up to 6930 mega volt amperes (MVA) or;
- HVDC connection options use 525 kV 2 GW voltage source links, which would require a converter station at each end. To come close to matching the AC hi-capacity circuits of 6930 MVA, the option would require at least three 2 GW HVDC connections between the Tee point and the new Walpole substation, and would require three converter stations at each substation.

- **Substation Works**

- 28 bay new Walpole 400 kV substation to accommodate required new circuits.
- 27 bay new Weston Marsh 400 kV to accommodate customer connection drivers

4.5.7 Table 4.7 below sets out the capital costs for Option F considering substation works and each technology option.

**Table 4.7– Option F capital cost for each technology option**

Item	Need	Capital cost			
Substation works	Facilitate generation and connect new circuits	£267.3m			
<b>New circuits</b>		<b>AC overhead line</b>	<b>AC cable</b>	<b>AC GIL</b>	<b>HVDC</b>

New circuit 32 km	New circuit across B9	£127.4m	£1,347.4m	£1,384.3m	£1,899.8m
<b>Total capital cost</b>		<b>£394.7m</b>	<b>£1,614.7m</b>	<b>£1,651.6m</b>	<b>£2,167.1m</b>

4.5.8 Table 4.8 below sets out the lifetime cost for the new circuit options, the lifetime costs are different for each circuit technology and are included as a differentiator between technologies. These costs are calculated using the methodology described in “Strategic options technical appendix 2020/2021 price base” in Appendix D of the SOR.

**Table 4.8 – Option F lifetime cost for each technology option**

	<b>AC overhead line</b>	<b>AC cable</b>	<b>AC GIL</b>	<b>HVDC</b>
<b>Capital cost of new circuits</b>	£127.4m	£1,347.4m	£1,384.3m	£1,899.8m
<b>NPV of cost of losses over 40 years</b>	£89.8m	£55.3m	£41.7m	£471.2m
<b>NPV of operation &amp; maintenance costs over 40 years</b>	£1.9m	£5.7m	£1.9m	£171.7m
<b>Lifetime cost of new circuits</b>	<b>£219m</b>	<b>£1,408m</b>	<b>£1,428m</b>	<b>£2,543m</b>

4.5.9 There were no additional secondary costs identified for Option F at this stage of option development.

4.5.10 From the environmental and technical appraisal considered, alongside capital and circuit lifetime costs, our starting presumption for further development of this option should it be selected, would be for a majority AC overhead line connection.

4.5.11 In summary, Option F is 32 km between a new Grimsby West substation to new Lincolnshire Connection substation(s), and from new Lincolnshire Connection substation(s) to the new Walpole substation, where the new Walpole substation is located along the Norwich Main to Walpole circuit, with EGL3 and EGL4 HVDC underground cables connecting at the new Walpole substation.

## 4.6 Summary of options

4.6.1 Table 4.9 below presents a summary comparison of the environmental, socioeconomic and technical constraints and cost variation for each of the options.

**Table 4.9 – Summary of options**

Criteria	Options (study area 1)			
	Option C	Option D	Option E	Option F
<b>Environmental &amp; Socioeconomic</b>	Relatively constrained in relation to both ecological, landscape and visual considerations. Option C requires a duck under of the 4ZM requiring additional Sealing End Compound infrastructure with associated landscape and visual impacts.	Relatively constrained in relation to both ecological, landscape and visual considerations. Option D requires the associated line entry reconfigurations in the vicinity of the new Weston Marsh substation to accommodate turning in existing and new circuits into the substation, with associated landscape and visual impacts.	Relatively constrained in relation to both ecological, landscape and visual considerations. Option E requires a line swap over of the existing 4ZM line with associated landscape and visual impacts.	Relatively constrained in relation to both ecological, landscape and visual considerations. Environmental constraints which are harder to mitigate due to the close proximity of designated sites along the Lincolnshire coast.
<b>Technical</b>				
Overhead line length	31 km	31 km	31 km	32 km
HVDC underground cable length	95 km	95 km	95 km	115 km
Network efficiency/benefits	Susceptible to circuit faults which could limit export capacity from the ECGG.	Less susceptible to circuit faults which could limit export capacity from the ECGG.	Susceptible to circuit faults which could limit export capacity from the ECGG.	Susceptible to circuit faults which could limit export capacity from the ECGG.
Construction programme	Medium outage complexity	High outage complexity	High outage complexity	Low outage complexity
<b>Capital cost</b>	£390.7	£390.7m	£390.7m	£394.7m
<b>Lifetime cost</b>	£212m	£212m	£212m	£219m

---

<b>Secondary Costs</b>	£50m	£12.5m	£2.5m	None identified at this stage
------------------------	------	--------	-------	-------------------------------

---

# 5. Appraisal of Options

## 5.1 Preferred Options

- 5.1.1 The assumed overhead line length for Options C, D and E is approximately 31 km, with Option F slightly longer at 32 km. The assumed HVDC cable route for the EGL projects for Options C, D and E is approximately 95km, with Option F longer at 115 km. Option D requires the associated line entry reconfigurations in the vicinity of the new Weston Marsh substation to accommodate turning in existing and new circuits into the substation. However, Option D would not need the Sealing End Compound infrastructure associated with an underground cable crossing of the 4ZM, as it is assumed the new overhead line would enter Weston Marsh from the North-East and exit the substation south of the existing 4ZM overhead line. Option E would also exclude the need for Sealing End Compound infrastructure associated with crossing the 4ZM, but would require a line swap-over. Option F would require overhead line, HVDC underground cable, substation, and converter station infrastructure to be located closer to the Wash than Options C, D and E, given the connection point would be located along the Norwich Main-Walpole circuits rather than the Burwell-Walpole circuits.
- 5.1.2 As noted in Section 2 and 4, the new Weston Marsh substation is required in all scenarios relating to the short-listed options. As such, to ensure that options have been compared fairly, the assessment process considered Weston Marsh substation within all option appraisals. The substation was not included within the appraisal of Options C, E and F. This is due to the new overhead line infrastructure of the Grimsby to Walpole project within these options not directly interfacing with the Weston Marsh substation. The key environmental and socioeconomic constraints affecting all four options are very similar. However, Option F was least preferred from an environmental and socioeconomic perspective as a result of its closer proximity to designated sites along the coast and the longer overhead line and HVDC underground cable lengths.
- 5.1.3 Option F also offered relatively poor performance in terms of network boundary capability reinforcement compared to the other four options. Options D and E have high outage complexity compared with Options C and F.
- 5.1.4 Option C has the highest cost (including capital, lifetime and secondary costs) due to the additional Sealing End Compound infrastructure, with Option E providing the lowest overall cost.
- 5.1.5 As noted within Section 2.1, the longer study areas, '2' and '3', would typically be considered as less preferred than study areas '1' as they would be expected to result to greater environmental impacts, technical constraints, and costs.
- 5.1.6 Based on the appraisal of options, and given the need for the inclusion of a new Weston Marsh substation, three options were identified as being capable of representing short list of more preferred potential configuration solutions for the Grimsby to Walpole southern connection point as follows:
- **Option C:** The new Walpole substation is located along the Burwell to Walpole circuit, with EGL3 and EGL4 HVDC underground cables connecting at the new Walpole substation. This option would require a duck under of the existing 4ZM



overhead line. Weston Marsh substation is required, but it does not directly interface with the new overhead line.

- **Option D:** The new Walpole substation is located along the Burwell to Walpole circuit, with EGL3 and EGL4 HVDC underground cables connecting at the new Walpole substation, together with a Weston Marsh substation. The Grimsby to Walpole overhead line would connect into the new Weston Marsh substation and continue to the new Walpole substation.
- **Option E:** The new Walpole substation is located along the Burwell to Walpole circuit, with EGL3 and EGL4 HVDC underground cables connecting at the new Walpole substation. The existing Bicker Fen-Walpole and Bicker Fen-Spalding North-Walpole circuits are diverted into the new Walpole substation. The Grimsby to Walpole overhead line terminates at existing Walpole (using bays vacated by a reconfiguration of the substation). Weston Marsh substation is required, however does not directly interface with the new overhead line.

5.1.7 Following the appraisal of options, Option F was discounted. This was due to the relatively poor performance in terms of network boundary capability reinforcement compared to the other four options. Furthermore, Option F was least preferred from an environmental and socioeconomic perspective as a result of its closer proximity to designated sites along the coast and the longer overhead line and HVDC underground cable lengths.

5.1.8 Discounting Option F confirms that the new Walpole substation will be situated on the Burwell Main to Walpole circuits, which serves to refine the study area for routing and siting in the Walpole region. The remaining options (C, D and E) are all electrically different, with different circuit configurations in the vicinity of the Spalding Tee, however the geographical differentiation of the options is minimal. A corridor is required between the Spalding Tee and the region south-west of the existing Walpole along the Burwell-Walpole circuits, where the new substation will be sited, regardless of which option is selected from options C, D and E. Each option involves the new circuit passing through the vicinity of the Spalding Tee. The different permutations between the options involve the interface between the new circuits and Weston Marsh: Grimsby to Walpole will either connect directly into and out of the substation, as in option D, or will bypass the substation either using an underground cable crossing or a line swap-over of the 4ZM close to Weston Marsh. The assessment work done to date in respect of options C, D and E provides sufficient geographical certainty for a study area to proceed to the routing and siting phase, and for a preferred corridor to be developed which will be presented at non-statutory consultation.

5.1.9 The option ultimately selected will depend on further technical analysis to investigate the benefits of or challenges posed by each option in terms of network resilience, fault levels, and transmission capability. This work will continue over the coming months and, in conjunction with feedback from non-statutory consultation, will inform the more detailed substation siting and overhead line alignment works which will be carried out in later design phases of the project.

# 6. Conclusion and Next Steps

## 6.1 Overview

- 6.1.1 This Report details the further work that has been undertaken in refining an appropriate study area for the routing and siting work for the proposed new Walpole substation, which was not specified in the SOR, (as amended by the SOR Addendum).
- 6.1.2 Given the evolving customer requirements in the Lincolnshire region, as detailed in the SOR Addendum, a new Weston Marsh substation is required, irrespective to the specific configuration option. It is concluded that the preferred configuration option(s) for the Grimsby to Walpole southern connection is one which includes a new 400 kV Weston Marsh substation. However, there are multiple possible options for how Grimsby to Walpole interfaces electrically with the Weston Marsh substation, which correspond with the options considered in this Report.
- 6.1.3 Situating the new Walpole substation on Walpole to Norwich Main circuits has been discounted on environmental and technical grounds, removing Option F from further consideration.
- 6.1.4 The remaining options (C, D and E) all include the new Walpole substation situated on the Burwell to Walpole circuits, however with different configurations with respect to Weston Marsh and the existing 4ZM overhead line. Following the appraisals in this Report, there is little to distinguish between the options at this stage. NGET therefore proposes to define a study area for routing and siting drawing on these three options, given that the options are geographically very similar in their requirements for routing and siting. Additional work to confirm the optimal system configuration and to assess the configuration options in more detail will continue as the project develops. The three options still under consideration are summarised below:
- **Option C:** The new Walpole substation is located along the Burwell to Walpole circuit, with EGL3 and EGL4 HVDC underground cables connecting at the new Walpole substation. This option would require an underground cable crossing of the existing 4ZM overhead line. Weston Marsh substation is required, but does not directly interface with the new overhead line.
  - **Option D:** The new Walpole substation is located along the Burwell to Walpole circuit, with EGL3 and EGL4 HVDC underground cables connecting at the new Walpole substation, together with a second new 400 kV substation (Weston Marsh). The Grimsby to Walpole overhead line would connect into Weston Marsh and continue to the new Walpole substation.
  - **Option E:** The new Walpole substation is located along the Burwell to Walpole circuit, with EGL3 and EGL4 HVDC underground cables connecting at the new Walpole substation. The existing Bicker Fen-Walpole and Bicker Fen-Spalding North-Walpole circuits are diverted into the new Walpole substation. The Grimsby to Walpole overhead line terminates at existing Walpole (using bays vacated by a reconfiguration of the substation). Weston Marsh substation is required, but does not directly interface with the new overhead line.
- 6.1.5 Whilst Options C, D and E are all similar in terms of their geographical requirements for routing and siting, they all propose different electrical configurations in the vicinity of

Weston Marsh. Grimsby to Walpole will either connect directly into and out of the substation, as in Option D, or will bypass the substation either using an underground cable crossing or a line swap-over of the 4ZM close to Weston Marsh, as in Options C or E. The difference in electrical configurations does not impact the decision-making process at this stage. The options are in the same geographical area for routing and siting purposes, and the need for a new Weston Marsh substation has been confirmed. Further technical studies are required to ascertain the feasibility of turning the Grimsby to Walpole circuits into Weston Marsh, which in turn, will confirm the electrical configuration.

Figure 6.1 - ECO 6 - new Grimsby West to new Lincolnshire Connection substation(s), new Lincolnshire Connection substation(s) via the new Weston Marsh substation to the new Walpole substation

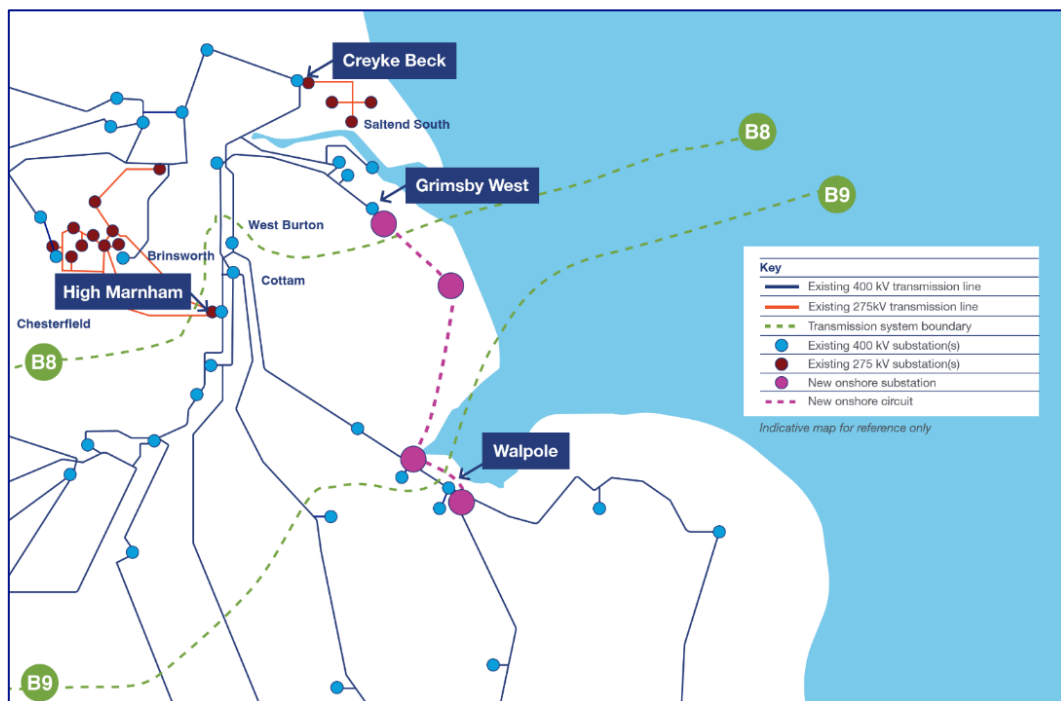

Figure 6. 1

## 6.2 Next steps

- 6.2.1 With the preference for the new Walpole substation to be situated on the Burwell-Walpole circuits confirmed and the high-level geographical search area requirements established with respect to Weston Marsh substation and the new overhead line, the Grimsby to Walpole project will now be taken forward to the next stage of development. This involves identification of a preliminary route corridor and graduated swathe, which indicates the emerging preference for where the potential infrastructure could be located the . This will be consulted on at non-statutory consultation to seek feedback from consultees and help shape the further development of the projects.
- 6.2.2 Further technical studies involving the electrical configurations of options C, D and E will be carried out regarding fault levels, network resilience, and transmission capability to confirm which is the preferred option. Whilst this work continues, the high-level routing and siting work for non-statutory consultation may proceed. The outputs of the further

technical studies, in conjunction with feedback from non-statutory consultation, will subsequently inform the alignment and configuration of infrastructure at Weston Marsh in later design phases.

# Appendices

# Appendix A

## Figure A - Option C1 & E1 Study Area

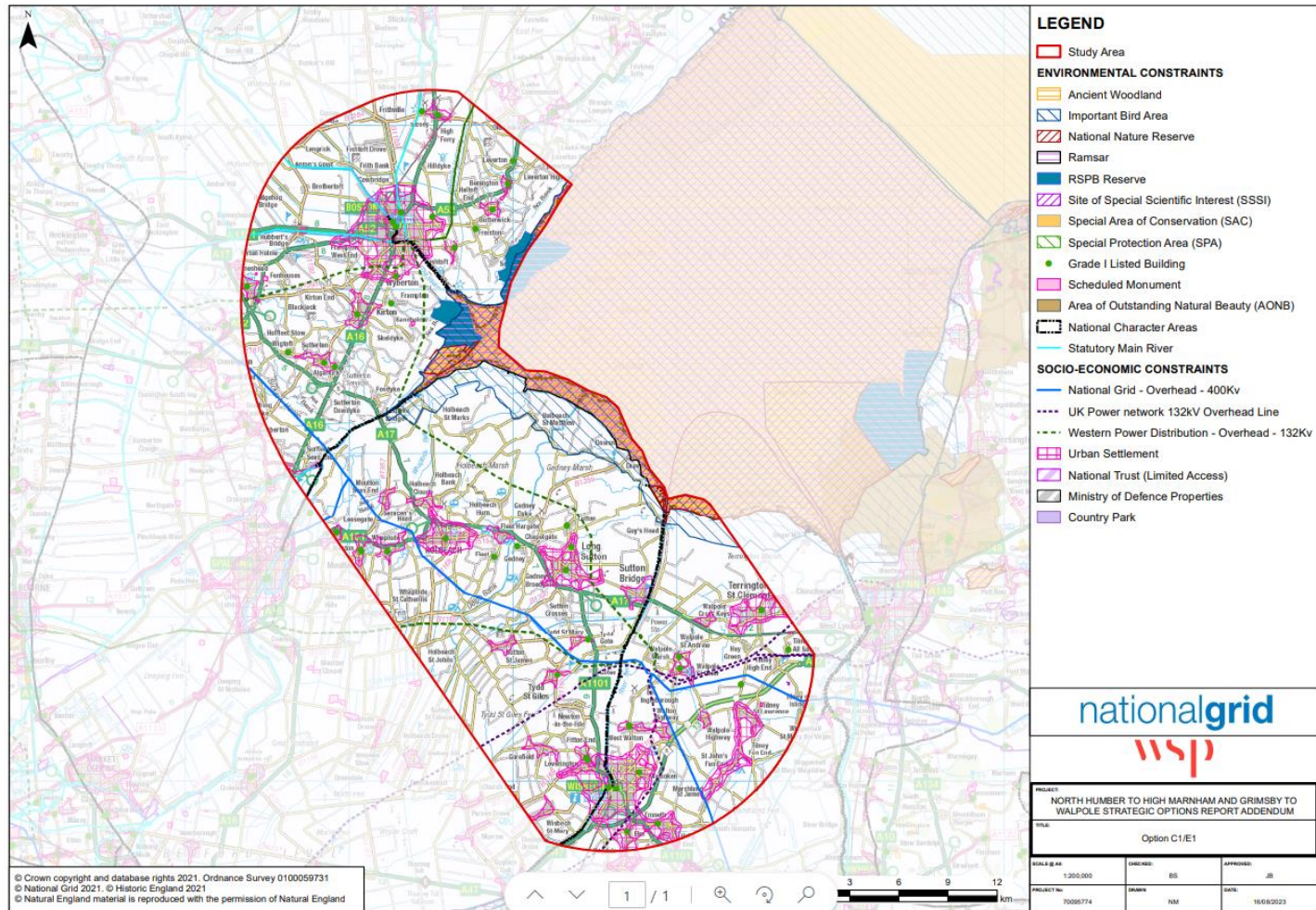

# Figure B - Option C2 & E2 Study Area

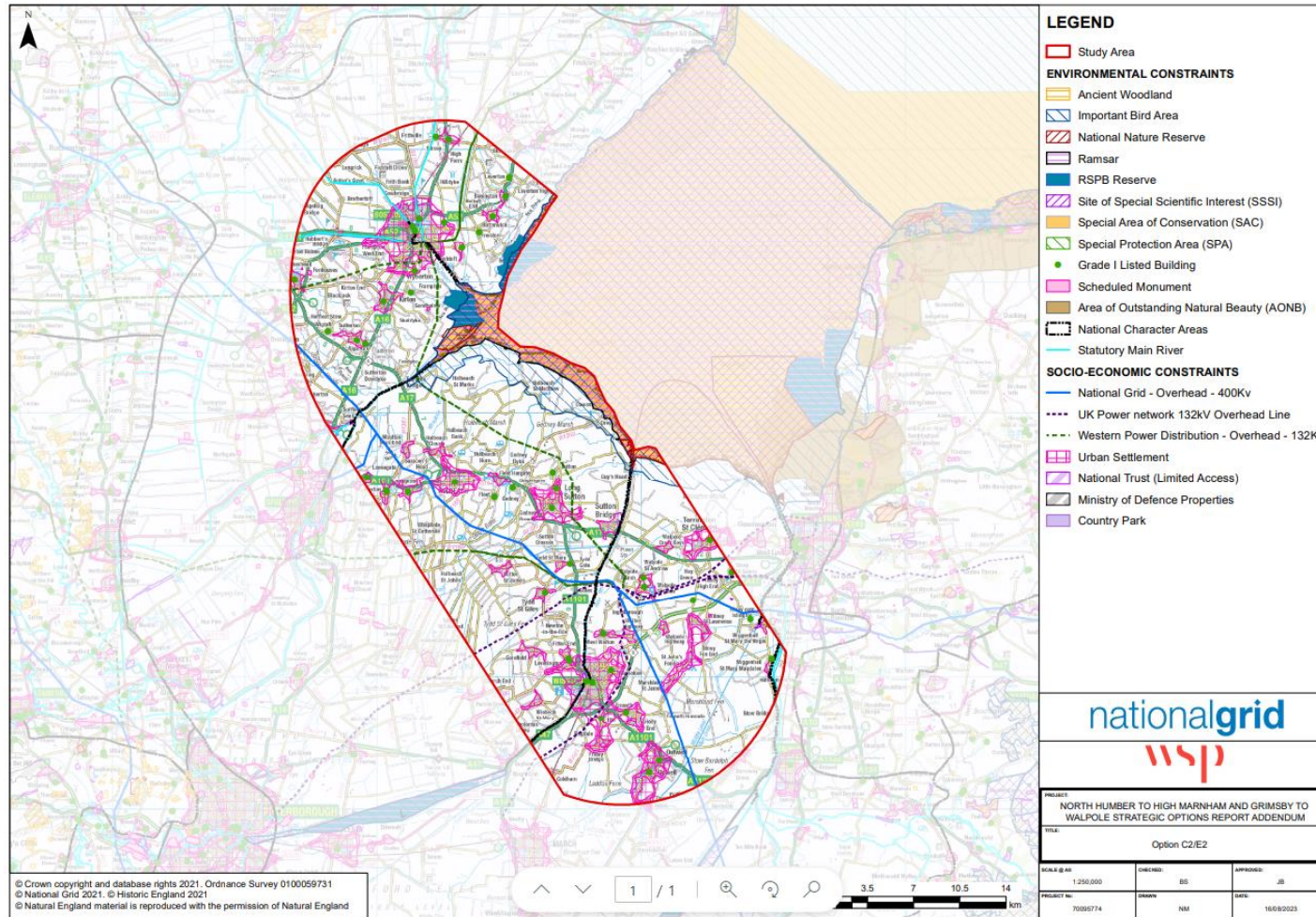

**Figure C - Option C3 & E3 Study Area**

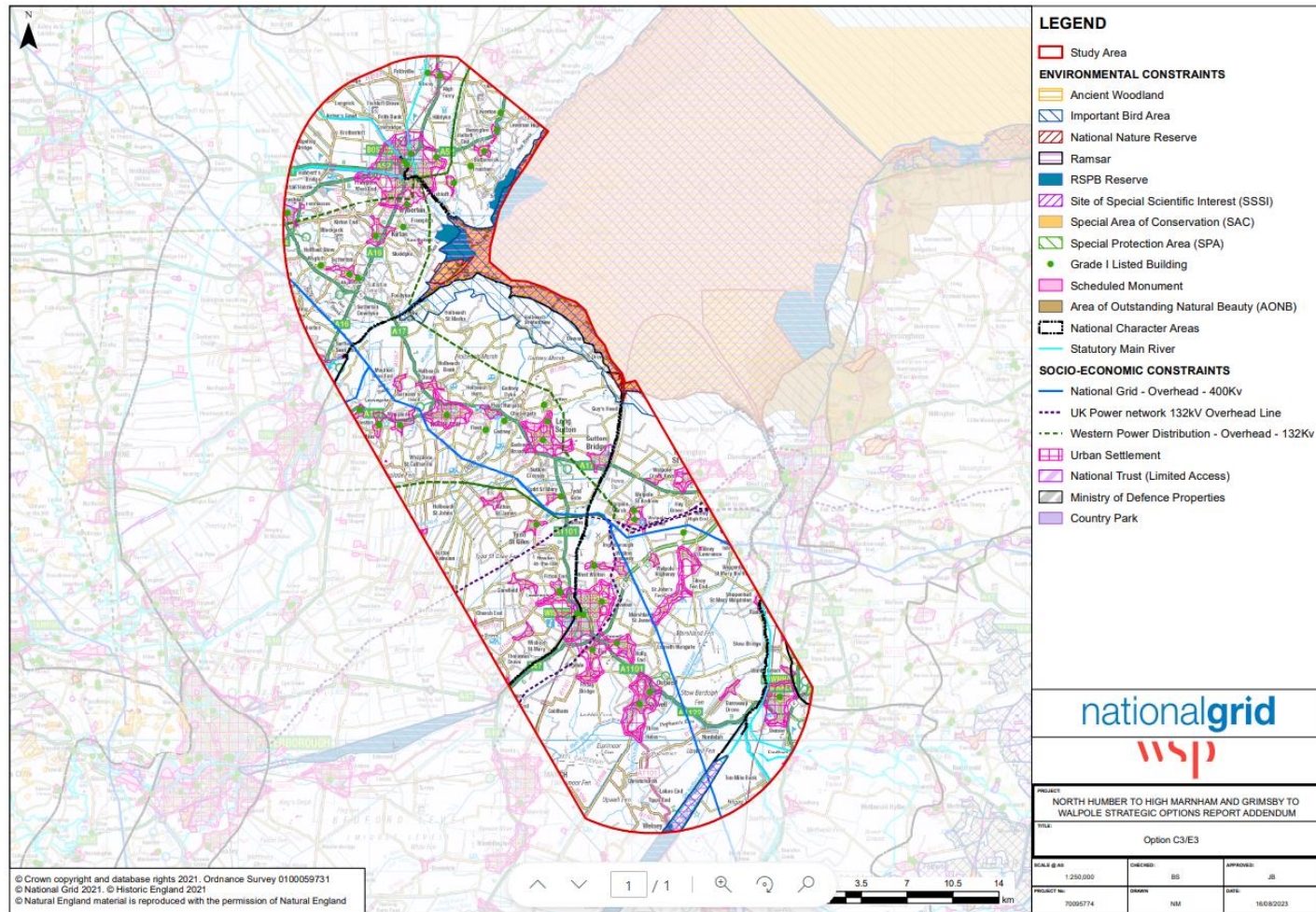
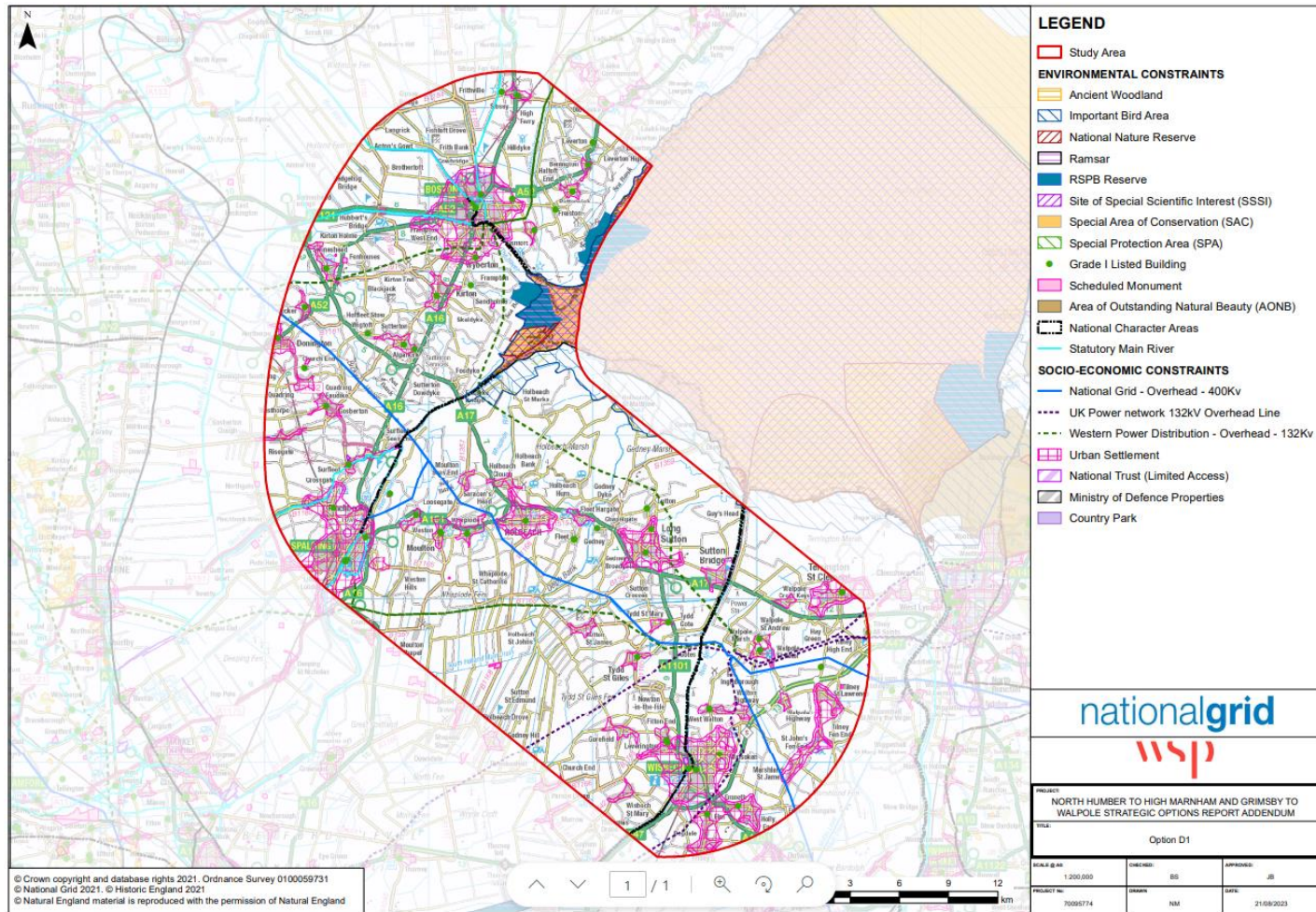
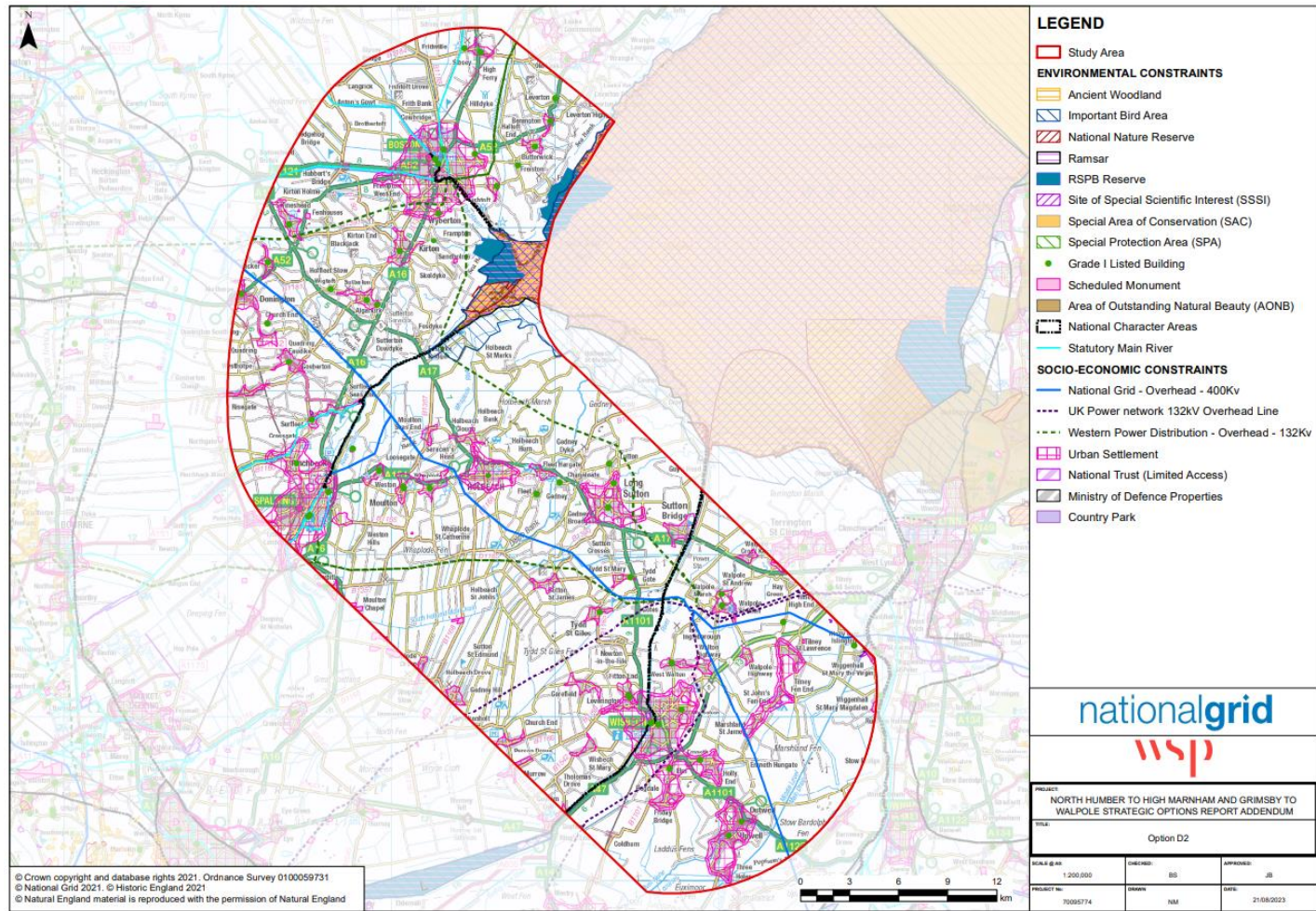



Figure D - Option D1 Study Area



# Figure E - Option D2 Study Area



# Figure F - Option D3 Study Area

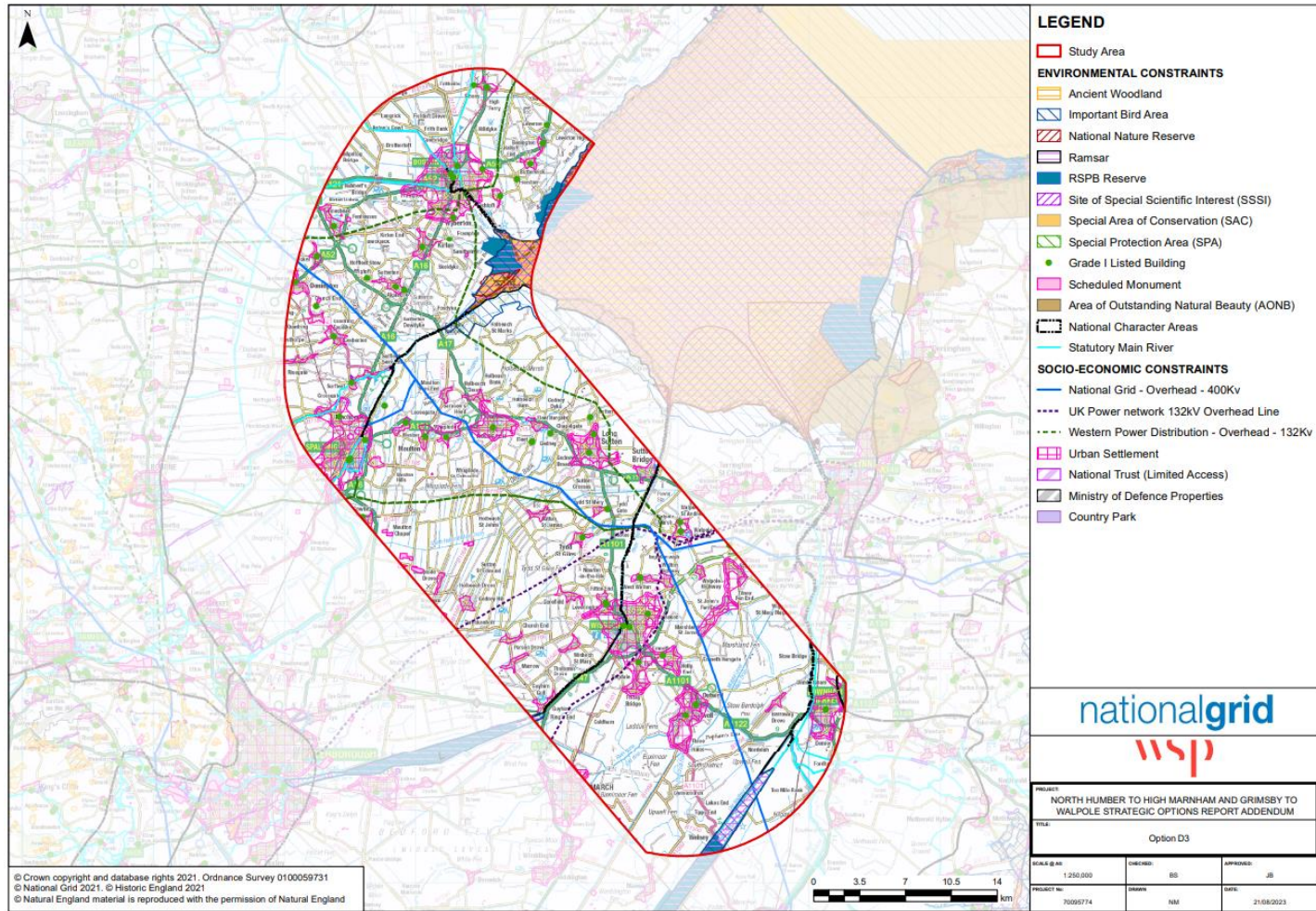

# Figure G - Option F1 Study Area

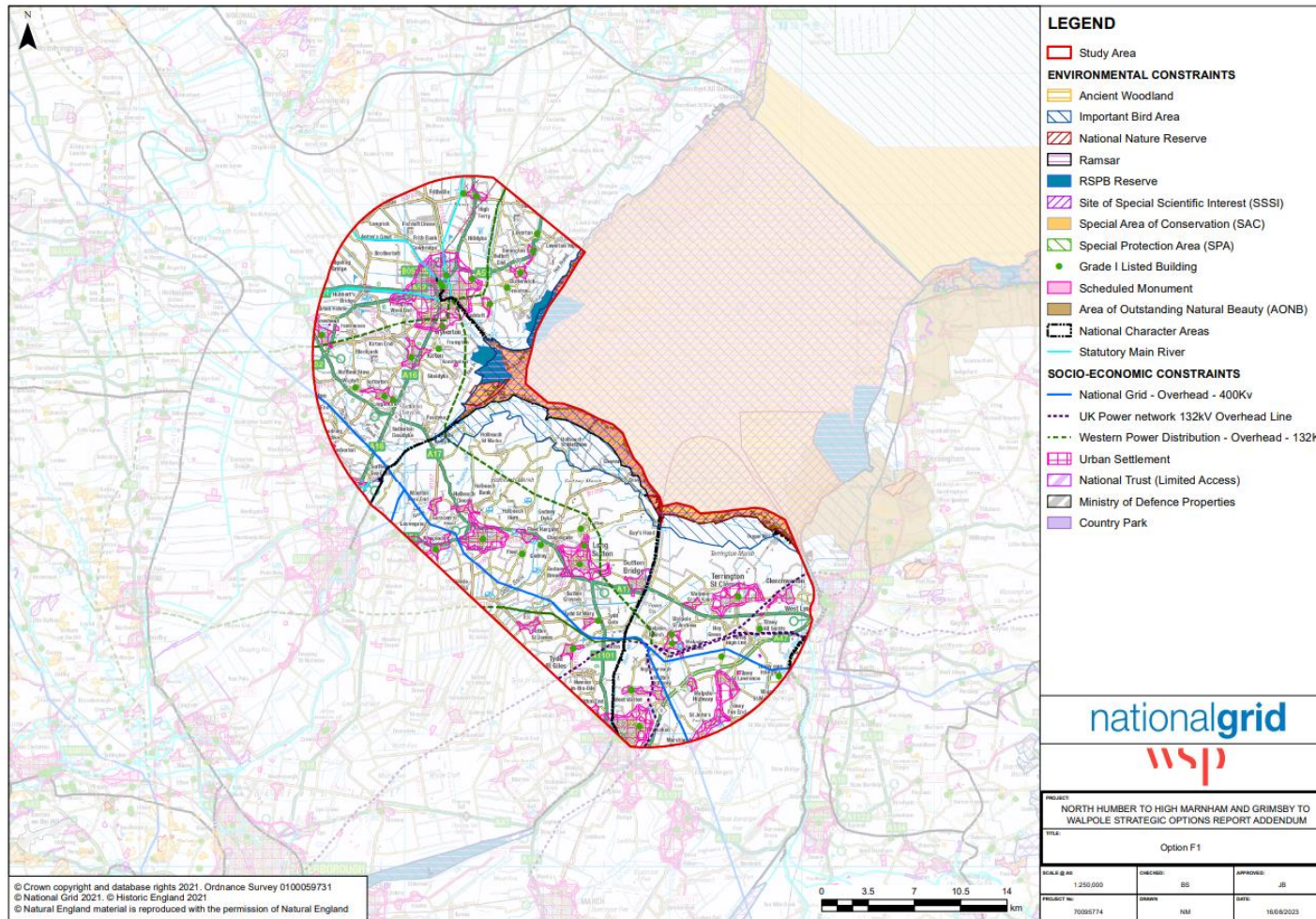

# Figure H - Option F2 Study Area

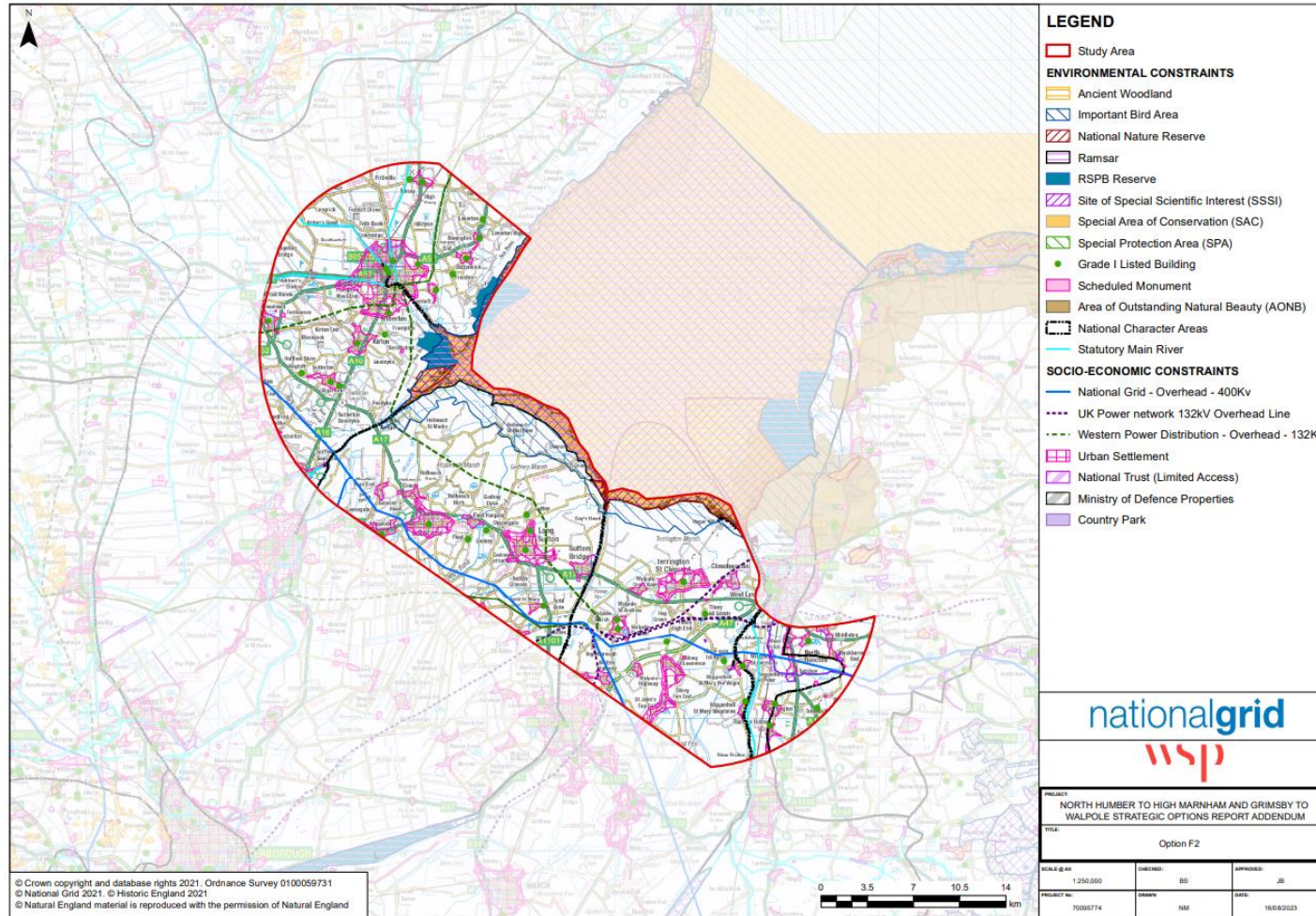

**Figure I - Option F3 Study Area**

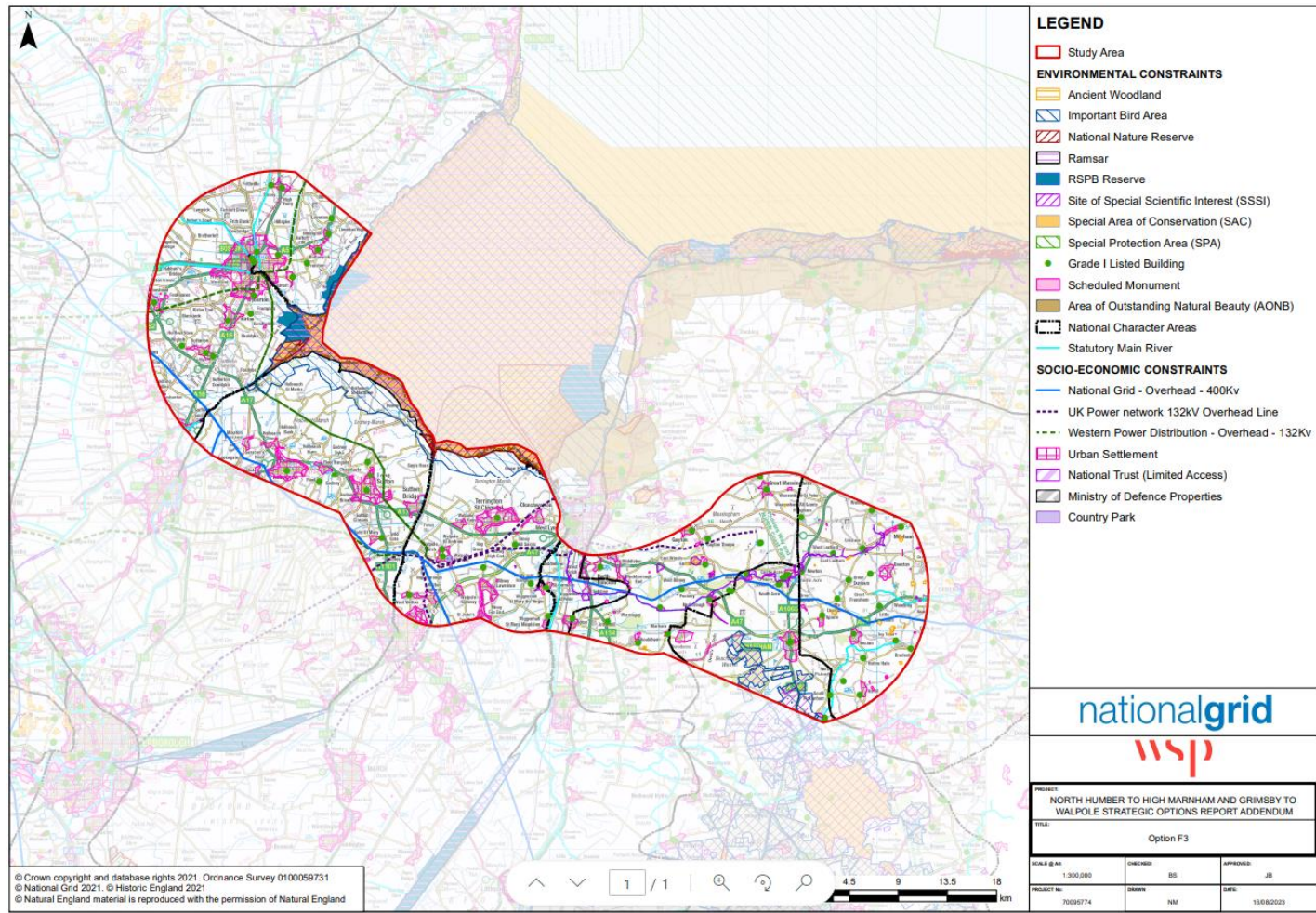

# Appendix B

<b>Key</b>	<b>Identification</b>
<b>GRIW4</b>	Existing Grimsby West 400 kV substation
<b>LCN4-A</b>	New Lincolnshire Connection 400 kV substation A
<b>LCN4-B</b>	New Lincolnshire Connection 400 kV substation B
<b>NEW WALP</b>	The new Walpole substation B 400 kV substation
<b>BICF4</b>	Existing Bicker Fen 400 kV substation
<b>SPLN4</b>	Existing Spalding North 400 kV substation
<b>WALP4</b>	Existing Walpole 400 kV substation
<b>BURW4</b>	Existing Burwell Main 400 kV substation
<b>NECT4</b>	Existing Necton 400 kV substation
<b>NORM4</b>	Existing Norwich Main 400 kV substation
<b>4ZM</b>	Existing 400 kV Overhead Line, running from West Burton to Waltham Cross
<b>4VV</b>	Existing 400 kV Overhead Line, running from Walpole to Norwich
<b>2WS</b>	Existing 400 kV Overhead Line, running from Weston Marsh to Spalding

National Grid plc  
National Grid House,  
Warwick Technology Park,  
Gallows Hill, Warwick.  
CV34 6DA United Kingdom

Registered in England and Wales  
No. 4031152  
[nationalgrid.com](http://nationalgrid.com)