

CONSULTATION APPENDICES DOCUMENT

Illustrative Revised Draft of The Statement of the Connection Charging Methodology

Incorporating:

- (i) **Change to Connection Boundary and associated removal of Land Charges and Type B Termination Charges (CCM-M-07)**
- (ii) **Change to Calculation of Site Specific Maintenance Costs (CCM-M-07)**

12 September 2003

Appendix 1 – Proposed Changes to Chapter 1: Principles

Chapter 1: Principles

Costs and their Allocation

- 1.1 Connection charges enable National Grid to recover, with a reasonable rate of return, the costs involved in providing the assets, which afford connection to the transmission system.
- 1.2 Connection charges relate to the costs of assets installed solely for use by ~~one~~ **an individual** User ~~or a specified group of Users~~.
- ~~1.3 National Grid's connection charges encourage Users to share connection sites, as this promotes efficiencies in the provision of assets and other costs which can be realised and shared between Users.~~
- ~~1.41.3~~ National Grid's connection charges are designed not to discriminate between Users or classes of User. The methodology is applied to both connections that were in existence at Vesting (30 March 1990) and those that have been provided since.

Connection/Use of System Boundary

- ~~1.51.4~~ The first step in setting charges is to define the boundary between connection assets and transmission system infrastructure assets.
- 1.5 **Originally, at Vesting, a shallow connection boundary definition including spurs was adopted. In 1996, the OFFER approved that this be amended to a "Generation-Only Spurs" approach, and subsequently in 2003, following National Grid's extensive Charging Review, Ofgem approved further change to implement a shallow single user boundary definition with no spurs retained within connection.**
- 1.6 In general, **connection assets are now defined as those assets solely required to connect an individual User to the Transmission System, which are not and could not be shared by any other connected party.** ~~National Grid substation assets fall within the connection asset category. In addition, any overhead lines or cables or other assets defined in paragraph 1.10 to 1.13 below as Generation Only Spurs will also be treated as part of the connection category.~~ For the purposes of this Statement, all connection assets at a given location shall form a connection site.
- ~~1.7 There are however occasions where assets within a connection site are providing a benefit to more than a subset of users at that site and hence are not charged fully to the connectees but instead are charged at least in part to Transmission Network Use of System (TNUoS).~~
- ~~1.81.7~~ ~~Where there is no generation only spur, a~~ Connection assets are defined as all those **single user** assets which lie between the National Grid/User ownership boundary, **such that** ~~and~~:
- a) **for Double Busbar type connections, are those single user assets lying between the user's assets and the first National Grid owned substation, up to and including the Double Busbar Bay** ~~the point at which the overhead line conductors from the terminal tower or junction tower(s) are fixed to the substation~~

~~gantries of the outgoing feeder circuit at the first transmission voltage substation beyond the ownership boundary. The substation gantry is a connection asset;~~

or

~~b) for teed or mesh connections, are those single user assets up to, but not including, the HV disconnector in the case of cabled circuit entries, the busbar side of the cable sealing end of the outgoing feeder circuit at the first transmission voltage substation beyond the ownership boundary;~~

or

~~c) the transformer side clamp of the disconnector or earth switch on the first transmission voltage substation side of an National Grid owned transformer, where the outgoing feeder circuit of the first transmission voltage substation incorporates a transformer whose lower voltage is also a transmission voltage;~~

or

~~b) where the Ownership Boundary exists at a substation which operates at a Distribution Voltage and the substation is connected to the transmission system via a transformer feeder circuit where the lower voltage side of the transformer is a Distribution Voltage and the feeder operates at a transmission voltage and is over 2km in length, the boundary shall be on the HV side of the transformer at the point described in a) and b) above.~~

1.7 Banked connection arrangements are not included within the connection boundary.

~~1.9 The design of some connection sites may not be compatible with the four basic boundary definitions above. In these instances, a connection boundary consistent with the principles above will be applied. For example, one condition to acquire Trading Site status is for a party to have contiguous connection assets. This may lead to a different connection boundary than the above definition but that boundary will follow similar principles to the above.~~

Generation Only Spurs

~~1.10 The DGES in his proposals of 3 October 1996 for National Grid's price control indicated that a "Generation Only Spurs" approach to boundary definition should be adopted by National Grid. The 1997/98 LC10 Statement of Connection Charges reflected the principles, which the DGES set out in paragraph 9.12 of the October 1996 Proposals document.~~

~~1.11 National Grid also circulated a system map on the 15 October 1996 identifying Generation Only Spurs and referenced that map in its October and November 1996 Charging Letters on the basis of charging for 1997/98. The diagram illustrating these Generation Only Spurs is available upon request from the **Charging Team**.~~

~~1.12 In addition, for new generation connections, Generation Only Spurs are identified with reference to the following principles:~~

~~2) Normally Public Distribution System Operator or directly connected customer connection charges are confined to sub-station assets, that is, they do not include overhead lines or cables (other than those which constitute substation assets or where Users forming a trading site have opted for any overhead lines and cables to continue to be treated as connection);~~

- ~~? Overhead lines and cables are excluded in the calculation of generation connection charges if such overhead lines and cables are essential to connect demand at Public Distribution System Operator exit points;~~
- ~~? Generation Only Spurs (i.e. where there is no Public Distribution System Operator exit point) are included in the connection charges of the generator(s) concerned and are allocated between generators as appropriate in accordance with the allocation procedure at shared sites;~~
- ~~? In the case of "multiple spurs" which serve to connect both generation and demand at Public Distribution System Operator exit points, where not all these circuits are required by security standard to serve the Public Distribution System Operator exit point, the more costly circuits are classed as connection. For the avoidance of doubt multiple spurs serving generation only will be treated as connection assets;~~
- ~~? Generation Only Spurs also incorporate, for the purpose of calculating connection charges, an appropriate allocation of the sub-station assets at the "system" end of the Generation Only Spurs. This allocation is carried out in accordance with the "The Allocation of Connection Assets at Shared Sites";~~
- ~~? For the avoidance of doubt overhead conductors between terminal and junction towers and substation gantries (Down Droppers or cable equivalent) which do not have intermediate overhead line towers are not considered to be overhead lines and therefore such assets cannot be defined as Generation Only Spurs for the purpose of calculating connection charges;~~
- ~~? Generation adjustments (at 400kV and/or 275kV generation sites) apportion to TNUoS Charges a share of the connection charge payable on the lowest cost Generation Only Spur circuit, including lines, cables terminating switchgear and substation assets. The lowest cost circuit is identified with reference to the associated Net Asset Values excluding the switchgear.~~

~~1.13 An updated diagram showing all the current Generation Only Spurs is available upon request from the **Charging Team**.~~

Appendix 2 – Proposed Changes to Chapter 2: The Calculation of the Basic Annual Connection Charge for an Asset

Chapter 2: The Calculation of the Basic Annual Connection Charge for an Asset

Pre and Post Vesting Connections

- 2.1 Post Vesting connection assets are those connection assets that have been commissioned since 30 March 1990. Pre Vesting connection assets are those which were commissioned on or before the 30 March 1990.
- 2.2 The basic connection charge has two components. A non-capital component, for which both pre and post vesting assets are treated in the same way and a capital component for which there are slightly different options available for pre and post vesting assets. These are detailed below.

Calculation of the Gross Asset Value

- 2.3 The GAV represents the initial total cost of an asset to National Grid. For a new asset it will be the costs incurred by National Grid for the provision of that asset. Typically the GAV is made up of the following components:

Construction Costs - Costs of bought in services
National Grid Engineering - Allocated equipment and direct engineering cost
Interest During Construction – Financing cost
National Grid Liquidated Damages Premiums - Premium required to cover Liquidated damages if applicable.

Some of these elements may be optional at the User's request and are a matter of discussion and agreement at the time the connection agreement is entered into.

- 2.4 The GAV of an asset is re-valued each year normally using one of two methods. For ease of calculation, April is used as the base month.
- In the Modern Equivalent Asset (MEA) revaluation method, the GAV is indexed each year with reference to the prevailing price level for an asset which performs the same function as the original asset;
 - In the RPI revaluation method, the original cost of an asset is indexed each year by the Retail Price Index (RPI) formula set out in paragraph 2.6;
- 2.5 In the MEA revaluation method, the MEA value is based on a typical asset. An MEA ratio is calculated to account for specific site conditions, as follows:
- The outturn GAV (as calculated in paragraph 2.3 above) is re-indexed by RPI to the April of the Financial Year the Charging Date falls within;
 - This April figure is compared with the MEA value of the asset in the Financial Year the Charging Date falls within and a ratio calculated;
 - If the asset was commissioned at a Connection Site where, due to specific conditions, the asset cost more than the standard MEA value the ratio would be greater than 1. For example, if an asset cost 10% more to construct and

commission than the typical asset the MEA ratio would be 1.1. If, however, the asset was found only to cost 90% of the typical MEA value the ratio would be 0.9;

- The MEA ratio is then used in all future revaluations of the asset. The April GAV of the asset in any year is thus the current MEA value of the asset multiplied by the ratio calculated for the Financial Year the Charging Date falls within.

2.6 The RPI revaluation method is as follows:

- The outturn GAV (as calculated in paragraph 2.3 above) is re-indexed by RPI to the April of the Financial Year the Charging Date falls within. This April GAV is thus known as the Base Amount;
- The Base Amount GAV is then indexed to the following April by using the RPI formula used in National Grid's Price Control. April GAVs for subsequent years are found using the same process of indexing by RPI.

i.e. $GAV_n = GAV_{n-1} * RPI_n$

- The RPI calculation for year n is as follows:

$$RPI_n = \frac{[\text{May to October average RPI Index}]_{n-1}}{[\text{May to October average RPI Index}]_{n-2}}$$

Calculation of Net Asset Value

2.7 The Net Asset Value (NAV) of each asset for year n, used for charge calculation, is the average (mid year) depreciated GAV of the asset. The following formula calculates the NAV of an asset, where A_n is the age of the asset (number of completed charging years old) in year n:

$$NAV_n = GAV_n * \frac{\text{Depreciation Period} - (A_n + 0.5)}{\text{Depreciation Period}}$$

2.8 In constant price terms an asset with an initial GAV of £1m and a depreciation period of 40 years will normally have a NAV in the year of its commissioning of £0.9875m (i.e. a reduction of 1.25%) and in its second year of £0.9625m (i.e. a further reduction of 2.5% or one fortieth of the initial GAV). This process will continue with an annual reduction of 2.5% for each year of the asset's life.

Capital Components of the Connection charge for Post Vesting Connection Assets

2.9 The standard terms for a connection offer will be:

- 40 year life (with straight line depreciation);
- RPI indexation

2.10 In addition a number of options exist:

- a capital contribution based on the allocated GAV at the time of commissioning will reduce capital. Typically a capital contribution will include costs to cover the

elements outlined below and charges are calculated as set out in the equations below;

- Construction costs
- National Grid Engineering costs (Engineering Charge x job hours)
- Interest During Construction (IDC)
- Return element (6%)
- National Grid Liquidated Damages Premium (LD) (if applicable)

General Formula:

Capital Contribution Charge = (Construction Costs + Engineering Charges) x (1+Return %) + IDC + LD Premium

- MEA revaluation which is combined with a 7.5% rate of return, as against 6% on the standard RPI basis;
- annual charges based on depreciation periods other than 40 years;
- annuity based charging;
- indexation of GAVs based on principles other than MEA revaluation and RPI indexation. No alternative forms of indexation have been employed to date.

2.11 For new connection assets, should a User wish to agree to one or more of the options detailed above, instead of the standard connection terms, the return elements charged by National Grid may also vary to reflect the re-balancing of risk between National Grid and the User. For example, if Users choose a different indexation method, an appropriate rate of return for such indexation method will be derived.

Capital Components of the Connection charge for Pre Vesting Connection Assets

2.12 The basis of connection charges for assets commissioned on or before 30 March 1990 is broadly the same as the standard terms for connections made since 30 March 1990. Specifically charges for pre vesting connection assets are based on the following principles:

- The GAV is the 1996/97 charging GAV (MEA re-valued from vesting) subsequently indexed by the same measure of RPI as used in National Grid's Price Control;
- 40 year life (with straight line depreciation);
- 6% rate of return

2.13 Pre-vesting 1996 MEA GAVs for User's' connection sites are available from National Grid on request from the **Charging Team**.

Non-Capital Components - Charging for Maintenance and Transmission Running Costs

2.14 The non-capital component of the connection charge is divided into two parts, as set out below. Both of these non-capital elements will normally be identified in the charging appendices of relevant Bilateral Agreements.

Part A: Site Specific Maintenance Charges

2.15 This is a maintenance only component which is calculated on a site specific basis **for assets** and also recovers a proportion of the overheads associated with **National Grid's** ~~the~~ maintenance activity **for connection assets**.

~~2.16~~ Users' site specific maintenance charges **for assets** are based on **actual forecasts of** site costs ~~derived from a three year rolling average of historic actual costs for the relevant charging year as~~ reported in National Grid's maintenance cost capture system. ~~The three years data being those reported for years t-2, t-3 and t-4, where t is defined as the year for which charges are being set. The three year average calculated from the above data would then be used to apportion the expected maintenance costs to be incurred for the charging year t to form the site specific maintenance charges.~~

~~2.17~~ Thus **for a relevant charging year** 2003/04 charges, the **user will** ~~three years of reported (i.e. actual) site cost data used is for 1999/00, 2000/01 and 2001/02. The three year average calculated from the above data is used to apportion the expected~~ **be charged for** maintenance costs ~~to be incurred for connection assets on that site for that~~ charging year 2003/04 to form the site specific maintenance charges.

2.16 **As the site specific maintenance charge is based on actual costs, initially a charge based on an average apportionment of GAV will be levied across all sites. Initially, this will be 0.5% of GAV but will be subject to review as appropriate. Subsequently, in July after the end of the relevant year, there will be a site specific adjustment made to reflect the actual costs incurred and this will be incorporated into October invoices.**

~~2.18~~ New assets that have no historic reported site cost data are subject to a surrogate charge for the missing years of data. The surrogate charge for the missing years is based on a fixed maintenance factor that is derived from a sample of costs of maintaining new sites. The fixed maintenance factor is reviewed each price control period and is currently 0.5%.

~~2.19~~ A site specific charge is thus calculated for a connection site using the methodology described above. The site specific charge per asset is apportioned based on the ratio of the asset GAV to the total site GAV.

~~2.20~~ For overhead line and cabled assets, which form part of Generation Only Spurs, separate specific components are calculated. As these assets are not specific to a substation, the specific maintenance charge is based on an appropriate proportion of the forecast maintenance costs to be incurred on all overhead lines and cables on the main transmission system respectively. The charges are derived using three years of rolling average historic costs as set out in paragraph 2.17.

Part B: Transmission Running Costs

~~2.19~~ 2.17 The Transmission Running Cost factor is calculated each year to reflect the appropriate amount of other Transmission Running Costs (rates, operation, indirect

overheads) incurred by National Grid's Transmission Owner Activity (TO) function that should be attributed to connection assets. This is calculated by taking total Transmission Running Costs for the TO function and dividing by the total transmission business GAV. This cost factor is therefore expressed as a percentage of an asset's GAV. In 2003/04, the Transmission Running Cost factor is 1.60% of GAV.

2-202.18 For overhead line routes, which form part of Generation Only Spurs, the same Transmission Running Cost component as that calculated for substation assets is used. For cabled routes forming part of Generation Only Spurs, the Transmission Running Cost component is set as 1/14th of that calculated for overhead line Generation Only Spurs. This is to reflect the fact that cabled routes are generally 14 times more expensive than overhead line routes.

The Basic Annual Connection Charge Formula

2-232.19 The final charge for each connection asset in year n can be derived from the general formula below. This is illustrated more fully by the examples in **Appendix 2: Examples of Connection Charge Calculations.**

$$\text{Annual Connection Charge}_n = D_n (\text{GAV}_n) + R_n (\text{NAV}_n) + \text{SSF}_n (\text{RPIGAV}_n) + \text{TC}_n (\text{GAV}_n)$$

Where:

For n = year to which charge relates within the Depreciation Period

n = year to which charge relates
 GAV_n = GAV for year n re-valued by relevant indexation method
 RPIGAV_n = GAV for year n re-valued by RPI indexation
 NAV_n = NAV for year n based on re-valued GAV_n
 D_n = Depreciation rate as percentage (equal to 1/Depreciation Period) (typically 1/40 = 2.5% of GAV)
 R_n = real rate of return for chosen indexation method (6% for RPI indexation, 7.5% for MEA Indexation)
 SSF_n = Site Specific Factor for year n as a % (equal to the Site Specific Cost / Total Site GAV)
 TC_n = Transmission Running cost component for year n (other Transmission Owner Activity costs).

For n = year to which charge relates beyond the Depreciation Period

n = year to which charge relates
 GAV_n = GAV for year n re-valued by relevant indexation method
 RPIGAV_n = GAV for year n re-valued by RPI indexation
 NAV_n = 0
 D_n = 0
 R_n = real rate of return for chosen indexation method (6% for RPI indexation, 7.5% for MEA Indexation)
 SSF_n = Site Specific Factor for year n as a % (equal to the Site Specific Cost / Total Site GAV)
 TC_n = Transmission Running cost component for year n (other Transmission Owner Activity costs).

2.242.20 Note that, for the purposes of deriving asset specific charges for site specific maintenance, the RPI re-valued GAV is used. This is to ensure that the exact site charges are recovered from the assets at the site. The site costs are apportioned to the assets on the basis of the ratio of the asset GAV to total Site GAV. As different Users can choose different re-valuation methods for the same asset at a shared site, the RPI GAVs are used for simplicity to ensure the correct costs are recovered.

Adjustment for Capital Contributions

2.252.21 If a User chooses to make a 100% capital contribution towards their allocation of a connection asset then no capital charges will be payable and hence the connection charges for that asset would be calculated as follows:

$$\text{Annual Connection Charge}_n = \text{SSF}_n (\text{RPIGAV}_n) + \text{TC}_n (\text{GAV}_n)$$

2.262.22 If a User chooses to make a partial capital contribution towards their allocation of a connection asset, for example PCCF = 50%, then the connection charges for that asset would be calculated as follows:

$$\text{Annual Connection Charge}_n = D_n (\text{GAV}_n * \text{PCCF}) + R_n (\text{NAV}_n * \text{PCCF}) + \text{SSF}_n (\text{RPIGAV}_n) + \text{TC}_n (\text{GAV}_n)$$

PCCF = Partial Capital Contribution Factor

Allocation/Sharing of Connection Assets

~~2.27 Where more than one User is connected at a connection site, the use of certain connection assets and charges for such connection assets will be shared as those assets benefit more than one User. The sharing of connection charges between Users at the same site is determined by the allocation procedure and the relevant connection charges are shared to accord with such asset allocation.~~

~~2.28 Unless the parties have firm price agreements with firm allocations, the allocation of connection assets and sharing of relevant connection charges may change on the arrival or departure of another User at the particular connection site or due to developments of the transmission system. Examples of such situations are shown in **Chapter 10: The Connection Asset Allocation Process.**~~

~~2.29 At certain connection sites a proportion of the connection assets' charges may be allocated to TNUoS charges. This would be the case when the connection asset is deemed to have a wider system infrastructure function. Connection sites are designed to meet National Grid's Security Standard and, if additional assets are built for wider system needs or operational complexity, they will be allocated to TNUoS charges unless the assets have been built at the request of a User. Examples of instances where assets are allocated to TNUoS are sites classified as Bussing Points as set out in **Chapter 10: The Connection Asset Allocation Process**, assets installed for wider system benefit, and a part share of multiple Generation Only Spur circuits.~~

~~2.30 If a site ceases to be Bussing Point due to National Grid infrastructure works on the wider system the User will no longer receive the Bussing Point adjustment and none of the remaining connection assets will be allocated to TNUoS charges. In this instance it is likely that the User's connection charge will increase. Conversely, if a site becomes a Bussing Point due to National Grid infrastructure works on the wider system the User will receive the Bussing Point adjustment and some of the~~

~~remaining assets will be allocated to TNUoS charges. In this instance it is likely that the User's connection charge will reduce.~~

~~2.31 If Users at the same connection site opt for different depreciation periods, the GAV of the asset will be split according to the allocation detailed in the Appendix A of the Bilateral Agreement. The depreciation charges and thus the NAV of the asset will be calculated independently for each portion of the split GAV as described in paragraphs 2.7 and 2.8.~~

~~If a User connects to a connection site at which a capital contribution has been made, the User who made the capital contribution will receive a refund from National Grid. The refund is based on the change in allocation that results, the proportion of the assets for which the capital contribution was made and the current NAV of the asset.~~

Modification of Connection Assets

~~2.33~~ **2.23** Where a modification to an existing connection occurs at the User's request or due to developments to the transmission system, their annual connection charges will ~~be based on the allocation principles described above for~~ **reflect** any additional connection assets which are required to meet the User's requirements. Charges will continue to be levied for existing assets which remain in service, ~~although the allocation of connection assets and sharing of relevant connection charges may alter where the assets are shared.~~ Termination charges as described in **Chapter 5: Termination Charges** below will be charged for any existing connection assets made redundant as a result of the modification.

Calculation of User's Connection Charge for an asset

~~2.34~~ In order to calculate a particular User's connection charge for a connection asset, the general formulas shown in paragraphs ~~2.23 to 2.26~~ are multiplied by the asset allocation factor for the User as determined with reference to the principles set out in **Chapter 10: The Connection Asset Allocation Process.**

Appendix 3 – Proposed Changes to Chapter 3: Other Charges

Chapter 3: Other Charges

3.1 In addition to the basic annual connection charges set out above, the User may pay National Grid for certain other costs related to their connection. These will be set out in the Bilateral and Construction Agreements where appropriate and are described below.

One-off Works

3.2 To provide a connection, National Grid may need to carry out works on the transmission system, which although are directly attributable to the connection, may not give rise to additional connection assets. These works are defined as “one-offs” and examples are provided below in paragraph 3.4. Where the User is liable for a one-off charge, they will pay a charge equal to the cost of the works involved, together with a reasonable return, as shown in 3.5 below.

3.3 In addition, where a connection asset is updated and where this updating does not affect the Replacement Period, the User may pay a one-off charge equal to the cost of the work involved, together with a reasonable return, as shown in 3.5 below.

3.4 Typically, the following are liable for a One-off charge:

- Diverting or relocating existing transmission lines (without a change in the functionality of the assets)
- Any transport related or removal costs involved in the relocation of assets
- Intertrip schemes are charged to the triggering User unless the benefit is shared by more than one User then the charge is shared
- ~~All new protection works (including ferroresonance quenching equipment) at sites, other than the one connecting to, are charged to the triggering User⁴~~
- Write-off (termination) of assets. One-off termination payments (incorporating the outstanding NAV) are liable for connection assets (not infrastructure assets) terminated at the site where the party is connecting. If connection assets are terminated as a result at other connection sites, these are not charged for.
- Cost of removal and making good the condition of the connection site following write off of assets
- Stand-down and remobilisation costs
- Contamination charges
- Availability charges. Charges for bringing on a connection early or before fully complete to allow customer to commission own plant
- Acceleration or Delay Costs

~~⁴ Protection works at the connection site will be included within the annual connection charge for that site, rather than being a one-off charge.~~

- 3.5 For information, the general formula for the calculation of the one-off charge for new works is outlined below.

$$\text{One-off Charge} = (\text{Construction Costs} + \text{Engineering Charges}) \times (1 + \text{Return \%}) + \text{IDC} + \text{LD Premium}$$

Where: Engineering Charges = "Engineering Charge" x job hours
 Return % = 6%
 IDC = Interest During Construction
 LD Premium = National Grid Liquidated Damages Premium (if applicable)

- 3.6 The calculation of the one-off charge for write-off of assets is outlined below:

$$\text{Write-off Charge} = 100\% \text{ of remaining NAV of redundant assets}$$

- 3.7 One-offs are normally paid on an agreed date, which is usually upon completion of the works. However, arrangements may be agreed between National Grid and the User to pay the charge over a longer period. If a one off is paid over a longer period it is termed a Transmission Charge. It is usually a depreciating finance charge or annuity based charge with a rate of return element and may include agreement on a schedule of termination payments if the agreement is terminated before the end of the annuity period. The charge is usually inflated annually by the same RPI figure that is used to inflate GAVs, though Users can request alternative indexation methods.

Land

~~3.8 Where National Grid purchases land to facilitate a connection, a Land Charge Base Amount is calculated based upon a reasonable rate of return on the purchase costs incurred. If National Grid already owns the land but did not use it for operational purposes, an open market valuation of this land will be made and a reasonable rate of return on this will form the Land Charge Base Amount.~~

~~3.9 In the Financial Year in which the User's Charging Date occurs, as set out in the User's Bilateral Agreement, a Forecast Land Charge will be calculated as the Land Charge Base Amount multiplied by the RPI Index for the calendar month of the day which is midway between the day on which the Charging Date occurs and the end of the same Financial Year divided by the RPI Index of the monthly price base in which the Land Charge Base Amount is expressed.~~

~~3.10 At the end of the Financial Year in which the Charging Date occurs, the Land Charge will be calculated based upon the Land Charge Base Amount multiplied by the actual RPI Index for the calendar month of the day which is midway between the day on which the Charging Date occurs and the end of the same Financial Year divided by the RPI Index of the monthly price base in which the Land Charge Base Amount is expressed.~~

~~3.11 The reconciliation process for any difference between amounts calculated in paragraphs 3.9 and 3.10 above is set out in the CUSC.~~

~~3.12 The default position, unless agreed otherwise, is that in all subsequent Financial Years, the Land Charge will be calculated as the Land Charge Base Amount multiplied by the average RPI Index for the months May to October inclusive of the Financial Year immediately preceding the Financial Year being charged for, divided by the average~~

~~Retail Price Index for the months May to October inclusive for the Financial Year immediately preceding the Financial Year in which the monthly price base in which the Land Charge Base Amount is expressed occurs. In this case the Forecast Land Charge equals the Land Charge. However Users have the option to agree a different indexation with National Grid. If this indexation involves using forecast values, then a reconciliation process will be undertaken once actual values are known. The indexation will be set out in the relevant Appendix to the Bilateral Connection Agreement. No alternative forms of indexation have been employed to date.~~

$$\text{For Year } n \text{ Land Charge}_n = \frac{\text{LCBA}_b \times \text{RPI}_{n-1}}{\text{RPI}_{b-1}}$$

~~Where:~~

- ~~LCBA_b = Land charge base amount in year b values~~
- ~~RPI_{n-1} = Retail Price Index (average RPI for May to October inclusive) for the preceding Financial Year~~
- ~~RPI_{b-1} = Retail Price Index (average RPI for May to October inclusive) for the Financial Year immediately preceding the Financial Year in which the LCBA value is expressed~~

~~3.13 Where National Grid leases land for a connection site, the costs of this lease is either passed through to the User directly as an annual Land Charge or if National Grid has paid a lump sum to cover a number of years the User can pay this as a one-off charge.~~

Miscellaneous Charges

~~3.143.8~~ Other contract specific charges may be payable by the User, these will be set out in the Bilateral and Construction Agreements where appropriate.

Rental sites

~~3.153.9~~ Where National Grid owns a site that is embedded within a distribution network, the connection charge to the User is based on the capital costs and overheads but does not include maintenance charges.

Final Metering Scheme (FMS)/Energy Metering Systems

~~3.163.10~~ Charges for FMS metering are paid by the registrant of the FMS metering at the connection site. It is charged on a similar basis as other National Grid Connection Assets. The electronic components of the FMS metering have a 15 year replacement and depreciation period whilst the non-electronic components normally retain a 40 year replacement and depreciation period (or a user specified depreciation period as appropriate).

Appendix 4 – Proposed Changes to Chapter 4: Connection Agreements

Chapter 4: Connection Agreements

Indicative Agreement

- 4.1 The standard connection agreement offered by National Grid is an indicative price agreement. From the Charging Date as set out in the User's Bilateral Connection Agreement, the User's initial connection charge is based on a fair and reasonable estimate of the expected costs of the connection.

Outturning the Indicative Agreement

- 4.2 Once the works required to provide a new or modified connection are completed and the costs finalised, the connection scheme is "outturned". National Grid reconciles the monies paid by the User on the indicative charge basis against the charges that would have been payable based on the actual costs incurred in delivering the project together with any relevant interest. This process involves agreeing a new charging GAV (The Base Amount) with the User in line with the elements stated in paragraph 2.3 and then calculating connection charges with this GAV.
- 4.3 In addition, for Users that have chosen MEA revaluation their MEA ratios are agreed at outturn and this ratio is used for MEA re-valuation in subsequent years.
- 4.4 ~~If there is more than one User at the site that is affected by the scheme it is the User who initiated the scheme that agrees the outturn.~~ In the case of asset replacement where there is no initiating User the outturn is agreed with the **major relevant** User at the site ~~(i.e. the one with the largest connection charge at the site).~~

Firm Price Agreement

- 4.5 In addition to the options stated in paragraph 2.10 above, firm price agreements are also available. Typically with this option, the charges to be incurred, and any indexation, are agreed between National Grid and the User and connection charges are not recalculated once outturn costs are known². A typical example of a firm price agreement is:
- Capital Contribution
 - Firm Price GAV
 - ~~Firm allocations~~
 - Running Costs (based on a firm price GAV)
 - Fixed Schedule of Termination Amounts
- 4.6 When a User selects a firm price agreement some or all of the above elements can be made firm. Any elements of the agreement that have not been made firm will be charged on an indicative basis in accordance with this statement.
- 4.7 Final Sums and Consents costs are never made firm in a Firm Price Agreement. Details of both are set out in the Construction Agreement.

Monthly Connection Charges

~~² Unless new assets triggered as a result of a new firm price agreement are shared by existing Users, in which case these assets will be outturned~~

- 4.8 If the initial Charging Date does not fall within the current Financial Year being charged for and there are no revisions to charges during the year, the monthly connection charge will equal the annual connection charge divided by twelve.
- 4.9 For the Financial Year in which the Charging Date occurs (as set out in the User's Bilateral Agreement) or for any Financial Year in which a revision to charges has occurred during the Financial Year, for each complete calendar month from the Charging Date (or effective date of any charge revision) to the end of the Financial Year in which the Charging Date (or charge revision) occurs, the monthly connection charge shall be equal to the annual connection charge divided by twelve.
- 4.10 For each part of a calendar month, the charge will be calculated as one twelfth of the annual connection charge prorated by the ratio of the number of days from and including the Charging Date to the end of the month that the Charging Date falls in and the number of days in that month.
- 4.11 For example, say the annual connection charge for Financial Year 1999/2000 is £1.2m and the Charging Date falls on the 15th November 1999, the monthly charges for the Financial Year 1999/2000 would be as follows:
- November = $£1,200,000/12 * (16/30)$ = £53,333.33
 - Dec 99, Jan 00, Feb 00, Mar 00 = $£1,200,000/12$ = £100,000.00
- 4.12 The above treatment does not apply to elements such as Miscellaneous Charges (as defined in 3.8) and Transmission Charges (annuitised one-offs, as defined in 3.7). If the Charging Date falls within a Financial Year, then the full annual charge will remain payable and will be spread evenly over the remaining months. This is because these payments are an annuitisation of charges which would normally be paid up-front as one-off payments.

Appendix 5 – Proposed Changes to Chapter 5: Termination Charges

Chapter 5: Termination Charges

Charges Liable

5.1 Where a User wholly or partially disconnects from the transmission system they will pay a termination charge. They may become liable for this ~~charge when their actions affect asset allocation factors, e.g.~~ by submitting a termination notice or a modification application. The termination charge will be calculated as follows:

- Type A assets are connection assets which can be made redundant. The User will be liable to pay an amount equal to the NAV of such assets as at the end of the financial year in which termination or modification occurs plus
- The reasonable costs of removing such assets. These costs being inclusive of the costs of making good the condition of the connection site

~~? Type B assets are shared assets that are not made redundant. For these assets the User will pay a termination charge equal to their end of year NAV multiplied by the asset allocation factor (or the difference between the current and new allocation factor for partial terminations) as set out in Appendix A of the Bilateral Agreement. This payment protects the remaining Users at the site from an increase in capital charges on shared assets not rendered redundant~~

- If a connection asset is terminated before the end of a Financial Year, the connection charge for the full year remains payable. Any remaining Use of System Charges (TNUoS and BSUoS) also remain payable
- For assets which National Grid has determined to replace upon the expiry of the relevant Replacement Period in accordance with the provisions set out in the CUSC and in respect of which a notice to Disconnect or terminate has been served in respect of the Connection Site at which the assets were located; and due to the timing of the replacement of such assets, no Connection Charges will have become payable in respect of such assets by the User by the date of termination; the termination charges will include the reasonable costs incurred by National Grid in connection with the installation of such assets
- Previous capital contributions will be taken into account

5.2 The Calculation of Termination amounts for financial year n is as follows:

$$\text{Termination Charge}_n = \text{UoS}_n + \text{C}_n + \text{NAV}_{an} + (\text{AF} \times \text{NAV}_{bn}) + \text{R} - \text{CC}$$

Where:

UoS_n = Outstanding Use of System Charge for year (TNUoS and BSUoS)

C_n = Outstanding Connection Charge for year

NAV_{an} = NAV of Type A assets as at 31 March of financial year n

~~NAV_{bn} = NAV of Type B assets as at 31 March of financial year n~~

~~AF = Asset Allocation factor (difference in Pre and Post terminated asset allocation factor)~~

R = Reasonable costs of removal of redundant assets and making good

CC = An allowance for previously paid capital contributions

~~5.3 The NAV paid on assets not rendered redundant by the departing User will be treated as a capital contribution for the remaining Users at the site. This treatment will buffer the remaining Users from increases in capital charges on shared assets as a result of the departure of another User. Remaining Users will therefore continue to pay broadly the same capital charges as before, with the only increase potentially coming from the Site Specific Charge and the Transmission Running Cost Component.~~

5.3 **An** Examples of reasonable costs of removal for terminated assets and making good the condition of the site include the following:

5.4

- If National Grid terminates a **circuit breaker**~~bus section breaker~~ as a result of a User leaving a site, ~~then it is likely that National Grid would need to replace this switch with a section of busbar to retain the integrity of the substation.~~ This ~~may~~**would** also require modifications to the ~~busbar~~ protection **systems**.
- If an asset was terminated and its associated civils had been removed to 1m below ground then the levels would have to be made up. This is a common condition of planning consent.

Repayment on Re-Use of Assets

5.5 If any assets in respect of which a termination payment was made, are re-used at the same site or elsewhere on the system, including use by National Grid as infrastructure assets, National Grid will make a payment to the original terminating User to reflect the fact that the assets are being re-used.

5.6 The arrangements for such repayments for re-use of Type A Assets are that National Grid will pay the User a sum equal to the lower of:

- i.) the Termination Amount paid in respect of such National Grid Assets; or
- ii.) the NAV attributed to such National Grid Assets for charging purposes upon their re-use

less any reasonable costs incurred by National Grid in respect of the storage of those assets.

~~5.7 The arrangements for such repayments for re-use of Type B Assets are that National Grid will pay the User a sum equal to the lower of:~~

- ~~i.) the Termination Amount paid in respect of such National Grid Assets; or~~
- ~~ii.) the NAV attributed to such National Grid Assets for charging purposes upon their re-use.~~

5.85.7 The definition of re-use is set out in the CUSC. Where National Grid decides to dispose of a terminated asset where it is capable of re-use National Grid shall pay the User an appropriate proportion of the sale proceeds received.

~~In the Decision Paper on the charging methodologies, Ofgem set out its intention to consult on issues regarding Termination Amounts that had been the subject of a referral. Following its consultation Ofgem will publish a statement on the matters originally subject to determination and explain the reasons for its thinking. In the light of such a statement, National Grid will initiate any appropriate steps to revise its charging methodology within three months of the statement's publication.~~

Termination Amounts example 1

Two Users at a site, User A and User B, have the following requirements for a particular type of asset. User A has a requirement for 4 assets of a particular type and User B has a requirement for 2 assets of a particular type. There are 4 of this type of asset in total at the site. From the allocation guide applying the left hand rule (see ~~Error! Reference source not found.~~ ~~Error! Reference source not found.~~ ~~Error! Reference source not found.~~ ~~Error! Reference source not found.~~) the allocations are as follows:

User	1	2	3	4	Allocation
A	1/2	1/2	1	1	$(\frac{1}{2} + \frac{1}{2} + 1 + 1) / 4 = \frac{3}{4}$
B	1/2	1/2			$(\frac{1}{2} + \frac{1}{2}) / 4 = \frac{1}{4}$

Within the year User B wholly disconnects.
All assets are still required for the continued connection of User A.

Assuming the end year asset NAVs are all £1m, the termination amounts payable by User B are as follows:

? For all the retained assets, their allocated share of the end year NAV = $\frac{1}{4} * (\text{£1m} + \text{£1m} + \text{£1m} + \text{£1m}) = \text{£1m};$

- ? Any removal or making good charges;
- ? Remaining Connection charges for the rest of the year;
- ? Remaining Use of System Charges for the rest of the year.

Therefore, User A's allocations change to:

User	1	2	3	4	Allocation
A	1	1	1	1	100%

The £1m payment towards the retained assets is treated as a termination contribution against those assets, hence although User A's allocation of the assets increases to 100%, the termination contribution ensures that they see no increase in the capital component (depreciation + rate of return) of their charge as a result of the termination, i.e. their effective allocation for capital purposes is $(100\% - 25\%) = 75\%$.

They will however now take a 100% share of all the site specific maintenance and transmission running cost charges, hence their overall charges will increase.

Termination Amounts example 2

Two Users at a site, User A and User B, have the following requirements for a particular type of asset. User A has a requirement for 2 assets of a particular type and User B has a requirement for 4 assets of a particular type. There are 4 of this type of asset in total at the site. From the allocation guide, applying the left hand rule (see ~~Error! Reference source not found.~~) the allocations are as follows:

User	1	2	3	4	Allocation
A	$\frac{1}{2}$	$\frac{1}{2}$	-	-	$(\frac{1}{2} + \frac{1}{2})/4 = \frac{1}{4}$
B	$\frac{1}{2}$	$\frac{1}{2}$	1	1	$(\frac{1}{2} + \frac{1}{2} + 1 + 1)/4 = \frac{3}{4}$

Within the year User B wholly disconnects.

~~Two of the assets are identified as being able to be made redundant.~~

~~Two of the assets are identified as being required for the continued connection of User A.~~

~~Assuming the end year asset NAVs are all £1m, the termination amounts payable by User B are as follows:~~

~~? For the redundant assets, the full end year NAV = £1m + £1m = £2m~~

~~? For the retained assets, their allocated share of the end year NAV = $\frac{3}{4} * (£1m + £1m) = £1.5m$~~

~~? Any removal or making good charges~~

~~? Remaining Connection charges for the rest of the year~~

~~? Remaining Use of System Charges for the rest of the year~~

User A's allocations change to:

User	1	2	Allocation
A	1	1	100%

~~The £1.5m payment towards the retained assets is treated as a termination contribution against those assets, hence although User A's allocation of the assets increases to 100%, the termination contribution ensures that they see no increase in the capital component (depreciation + rate of return) of their charge as a result of the termination, i.e. their effective allocation for capital purposes is $(100\% - 75\%) = 25\%$.~~

~~They will however now take a 100% share of all the site specific maintenance and transmission running cost charges, hence their overall charges could increase or decrease.~~

Valuation of Assets that are re-used as connection assets or existing infrastructure assets re-allocated to connection

5.95.8 If an asset is reused following termination or allocated to connection when it has previously been allocated to TNUoS, a value needs to be determined for the purposes of connection charges. In both instances the connection charge will be based on the standard formula set out in paragraph ~~2.192-192.24~~. The Gross Asset Value will be based on the original construction costs and indexed by RPI, where original costs are not known a reasonable value will be agreed between National Grid and the User based on similar types of asset in use. The Net Asset Value will be calculated as if the asset had been in continuous service as a connection asset from its original commissioning date taking into account the depreciation period.

5.405.9 Where an asset has been refurbished or updated to bring it back into service a new value and an appropriate replacement period will be agreed between National

Grid and the User. This will be based on the value of similar types of asset in service and the costs of the refurbishment.

Appendix 6 – Proposed Changes to Chapter 6: Contestability

Chapter 6: Contestability

- 6.1 Some connection activities may be undertaken by the User. The activities are the provision, or construction, of connection assets, the financing of connection assets and the ongoing maintenance of those assets. While some Users have been keen to see contestability wherever possible, many believe that contestability should not prejudice system integrity, security and safety. These concerns have shaped the terms which are offered for contestability in construction and maintenance.

Contestability in Construction

- 6.2 Users wishing to provide (construct) connection assets have been able to do so since 1990. Formal arrangements for Users exercising this choice are available. Further information on User choice in construction can be obtained from the **Charging Team**.

Contestability in the Maintenance Service

- 6.3 National Grid has identified assets which could be maintained by Users without jeopardising system integrity and thus the interests of all National Grid Users. The two diagrams in **Example 6** of **Appendix 1: Illustrative Connection Charges** identify those assets which fall into this category. In broad terms, these are supergrid transformers and associated equipment. However, as certain activities related to the maintenance of these assets can also impinge on system security, those activities which are core to system security will remain with National Grid. The division between those activities which are contestable and non-contestable is set out below:

Non-Contestable

- Safety management
- Emergency response to operational requirements
- Wayleave management
- Maintenance policy and specification
- Site access
- Outage management
- Protection Maintenance

Contestable

- Routine planned and unplanned maintenance of equipment and civil works
- Provision of Maintenance spares
- Emergency works

- 6.4 Users opting to carry out these contestable activities for themselves will have to provide the activities as a complete package. It will not be possible for Users to select certain aspects of the contestable package in isolation.

~~6.5 If a User wishes to undertake the contestable activities at a shared connection site, the full agreement of all Users at that site will be required.~~

6.66.5 The site specific maintenance service charge will be adjusted to reflect situations where Users opt to provide these maintenance activities themselves. The site specific charge for that site will reflect solely the expected costs of National Grid's maintenance activity at that site.

6.76.6 The exact reduction in charges will depend on the period of time over which the User is carrying out the Contestable Maintenance Activity.

Contestability Procedure and Connection Terms

6.86.7 Users wishing to exercise choice in maintenance provision will enter into contracts to cover the provision of the contestable maintenance activities. A contractual relationship is essential as the contestable assets will remain under National Grid ownership. The contracts will ensure that the maintenance activities on these assets are consistent with those carried out on all connection assets. Each year the following notification procedure shall apply in respect of contestable maintenance to allow time for consideration and identification of contractual terms and the identification of charge adjustments:

15 September	Deadline for formal notification to National Grid of a User's intention to provide contestable maintenance from 1 April of the next financial year
Mid-September onwards	Period for contract negotiation
30 November	Deadline for execution of contract
Week commencing 2 January	Provisional issue of connection charges as from 1 April, adjusted to reflect that the User is providing contestable maintenance

6.96.8 Where one of the dates above is not a business day, the nearest business day before that date will apply. The terms of the contract for maintenance contestability may be referred to the Authority in the case of a dispute. ~~Where a site is shared between a number of Users, all parties at that site must agree to have the contestable maintenance provided by a party other than National Grid. If they fail to agree, National Grid will remain the maintenance provider for all assets at the connection site and the site specific charges will remain.~~

Appendix 7 – Proposed Changes to Chapter 7: Asset Replacement

Chapter 7: Asset Replacement

- 7.1 Appendix A of a User's Bilateral Connection Agreement specifies the age (number of complete charging years old), for charging purposes, of each of the National Grid assets at the Connection Site for the corresponding Financial Year. Connection charges are calculated on the assumption that the assets will not need to be replaced until the charging age has reached the duration of the asset's Replacement Period.

If a connection asset is to be replaced National Grid will enter into an agreement for the replacement with the User. Where replacement occurs before the original asset's charging age has reached the duration of its Replacement Period, National Grid will continue to charge for the original asset and make no charge to the existing User(s) for the new asset until the original asset's charging age has reached the duration of its Replacement Period.

Where the replacement occurs after the original asset's charging age has reached the duration of its Replacement Period, National Grid will charge on the basis of the original asset until replaced and on the basis of the new asset on completion of the works.

- 7.2 When the original asset's charging age has reached the duration of its Replacement Period the User's charge will be calculated on the then Net Asset Value of the new asset. The new asset begins depreciating for charging purposes upon completion of the asset replacement.

The Basic Annual Connection Charge Formulae are set out in **Chapter 2: The Basic Annual Connection Charge Formula.**

Asset Replacement that includes a change of Voltage

- 7.3 There are a number of situations where an asset replacement scheme may involve a change in the voltage level of a User's connection assets. These replacement schemes can take place over a number of years and may involve a long transitory period in which connection assets are operational at both voltage levels.
- 7.4 These situations are inevitably different from case to case and hence further charging principles will need to be developed over time as more experience is gained. Set out below are some initial generic principles which have been applied to date. This methodology will be updated as experience develops.
- 7.5 The general principles used to date are to ensure that, in the transitory period of an asset replacement scheme, the User does not pay for two full transmission voltage substations and that the charges levied reflect the Replacement Period of the original connection assets. In addition, in line with paragraph 7.1 above, charges will only be levied for the new assets once the original assets would have required replacement.
- 7.6 For example, National Grid, in investing to meet a future Security Standard need on the main transmission system, may require the asset replacement of an existing 275kV substation with a 400kV substation prior to the expiry of the original assets' Replacement Period. In this case, National Grid will seek to recover the connection asset component via connection charges when the assets replaced were due for

asset replacement. Prior to this, the User should not see an increase in charges and therefore the investment costs would be recovered through TNUoS charges.

In addition, if in the interim stage the User has say one transformer connected to the 275kV substation and one transformer connected to the 400kV substation, the charge will comprise an appropriate proportion of the HV assets at each site and not the full costs of the two substations. ~~This would not be the case if the allocation rules as set out in Chapter 10: The Connection Asset Allocation Process were strictly applied as the general rule is allocation up to the first transmission voltage.~~ Note that the above described treatment is only made for transitory asset replacement and not enduring configurations where a User has connection assets connected to two different voltage substations.

Appendix 8 – Proposed Changes to Chapter 8: Data Requirements

Chapter 8: Data Requirements

~~8.1 Under the current connection charging methodology no data is required from Users. The following data is required by National Grid in order to calculate the connection charges payable by the User.~~

~~8.2 For Users who are owners or operators of a User System (e.g., Distribution companies) or Directly Connected Customers, a forecast for the following Financial Year of the Natural Demand attributable to each Grid Supply Point equal to the forecasts of Natural Demand under both Annual Average Cold Spell (ACS) Conditions and a forecast of the average metered Demand attributable to such Grid Supply Point for the National Grid triad. This data is published in Table 2.4 of the Seven Year Statement and is compiled from week 24 data submitted in accordance with the Grid Code.~~

~~8.3 This data allows National Grid to calculate the allocation of Supergrid Transformers and Main Transmission Incomers as set out in the Connection Asset Allocation Process.~~

Appendix 9 - Proposed Changes to Appendix 1: Illustrative Connection Charges

Appendix 1: Illustrative Connection Charges

2003/2004 First Year Connection Charges based on the RPI Method (6% rate of return)

The following table provides an indication of typical charges for new connection assets. Before using the table, it is important to read through the notes below as they explain the assumptions used in calculating the figures.

Calculation of Gross Asset Value (GAV)

The GAV figures in the following table were calculated using the following assumptions:

- Each asset is new
- The GAV includes estimated costs of construction, engineering, Interest During Construction and Liquidated Damages premiums

For details of the Calculation of the Gross Asset Value, see Chapter 2 of this Statement.

Calculation of first year connection charge

The first year connection charges in the following table were calculated using the following assumptions:

- The assets are new
- The assets are depreciated over 40 years
- The rate of return is assumed to be 6% for RPI indexation
- The connection charges include maintenance costs
- The connection charges include Transmission Running Costs at a rate of 1.60% of the GAV

For details of the Basic Annual Connection Charge Formula, see Chapter 2 of this Statement.

Please note that the actual charges will depend on the specific assets at a site. Agreement specific NAVs and GAVs for each User will be made available on request.

Notes on Assets

Unless specified otherwise in the notes following the table, the charges in the first section of the table include electrical and civil costs for outdoor assets.

For the assets specified as indoor, the figures provided include through wall bushing costs, although not all bays require these so a lower cost may apply.

Cable sealing end costs include test charges and other fixed items such as oil tanks, link pillars and boxes.

Cable costs include joints at the normal maximum drum length interval for the size of cable, plus auxiliary cables, bonding leads, and associated contractors' engineering and design costs.

	£000's					
	400kV		275kV		132kV	
	GAV	Charge	GAV	Charge	GAV	Charge
Double Busbar Bay	1912	201	1490	157	504	53
Bus Coupler	1553	163	1179	124	415	44
Bus Section	1365	144	1037	109	432	45
Reserve Busbar Bay	326	34	252	27	83	9
Crossover Connections¹	122	13	74	8	44	5
Single Busbar Bay	1534	161			387	41
Complete Mesh Busbar Array²	2440	257	1654	174	845	89
Supergrid Transformer Connection ³¹	309	33	233	24	111	12
Banked SGT Connection⁴	466	49	410	43	272	29
Mesh Section Breaker Bay⁵	986	104	767	81	288	30
Line Connection	761	80	640	67	256	27
Mesh Arrangement (Single Switch)⁶	1952	205	1220	128	845	89
Generator Bay (NGC Busbars only)⁷	1143	120	1006	106	420	44
Bus Section (Indoor)	4343	457	2476	261	1228	129
Reserve Busbar Bay (Indoor)	820	86	252	27	83	9
Transformer Cables 100m (incl. cable sealing ends)⁸²						
120MVA			732	77	229	24
180MVA	1097	115	732	77	237	25
240MVA	1123	118	739	78	245	26
750MVA	1138	120	851	90		
OHLs 10km Double Circuit⁸						
2 x 700 mm² L12 (All Aluminium Alloy Conductor)	6728	708				
4 x 400 mm² L6 (Aluminium Conductor Steel Reinforced)	9060	954				
2 x 400 mm² L8 (ACSR)	5382	566				
2 x 175 mm² L3 (ACSR)			3678	387	3076	324
Line Modifications¹⁰		500		350		150
Cables 1 km Urban (incl. cable sealing ends)¹⁴						
L12 (equivalent to OHL 2 x 700 mm² L12)	18404	1937				
L6 (equivalent to OHL 4 x 400 mm² L6)	24774	2607				
L8 (equivalent to OHL 2 x 400 mm² L8)	12628	1329	8705	916		
L3 (equivalent to OHL 2 x 175 mm² L3)			5590	588	2912	306
Transformers¹²³						
45MVA 132/66kV					875	92
90MVA 132/33kV					842	89
120MVA 275/33kV			1695	178		
180MVA 275/66kV			1834	193		
180MVA 275/132kV			1816	191		
240MVA 275/132kV			1381	145		
240MVA 400/132kV	1732	182				
750MVA 400/275kV	2053	216				

Notes on Assets

- ~~1 Crossover connections cross the central busbar to join the outer bars at back-to-back substations~~
- ~~2 Fixed costs for 2, 3 or 4 switch mesh arrangement~~
- ~~31 Transformer disconnector/mesh bay only?~~
- ~~4 Civil costs for banked transformer feeder are for additional connections and disconnector at an existing substation and additional protection for second transformer~~
- ~~5 Mesh line connection bay~~
- ~~6 Fixed costs for 1 switch mesh arrangement~~
- ~~7 Cost of busbar connections only, including cost of busbars and their supports, infrastructure and telecoms interface to power station~~
- ~~82 Transformer cable ratings are based on winter soil conditions~~
- ~~9 Assumes a normal route of 30km or more in length with 70% of towers of suspension type~~
- ~~10 Estimated cost of diverting or relocating existing transmission lines~~
- ~~11 Cable ratings assumed to correspond to post fault continuous winter rating of the equivalent overhead line. Route profiles taken to be reasonably flat and requiring only one stop joint bay per 2 km. Cost of minor works (e.g. diversion of services or obtaining consents over public or private property) are not included, nor are costs of railway or river crossings.~~
- ~~12~~
~~3 Charges include civil costs of plinth and noise enclosure and estimated transport costs, but not costs of oil dump tank and fire trap moat. Transport costs do not include hiring heavy load sea transportation or roll-on roll-off ships.~~

Connection Examples
Example 1

NEW 400/132kV SUPERGRID CONNECTION
SINGLE SWITCH MESH TYPE

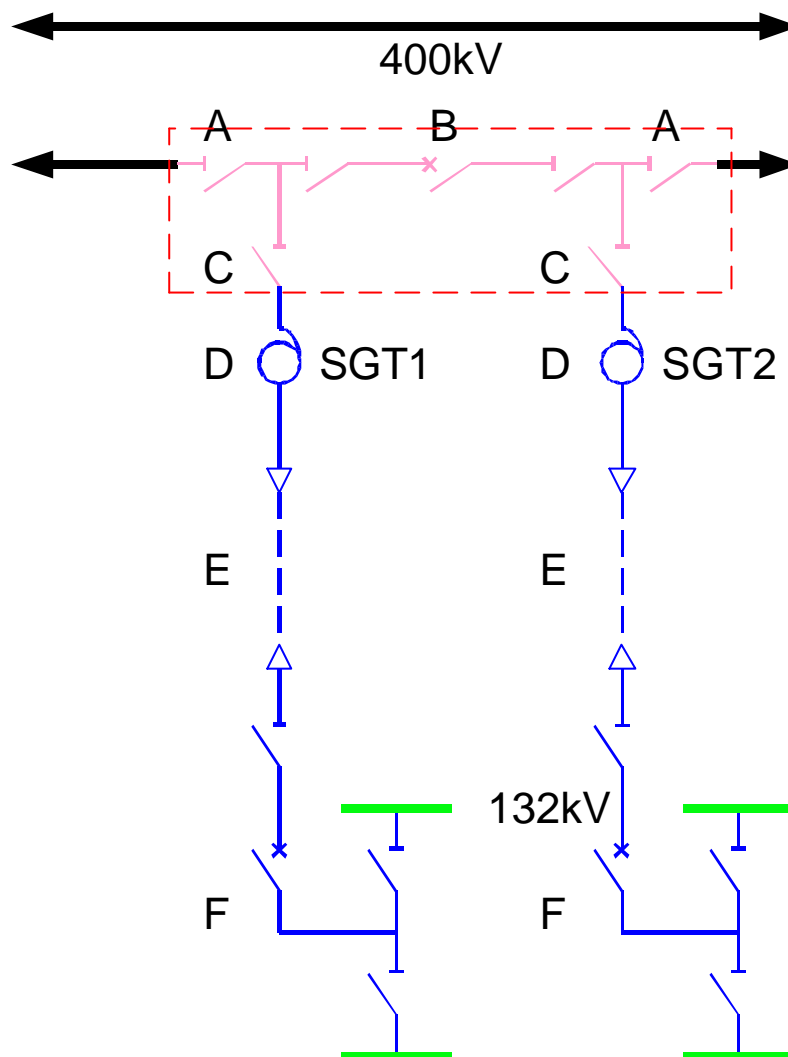

KEY:

- Existing NGC Assets
- New NGC Assets
- New NGC Assets wholly charged to customer
- Customer Assets
- - - - Change marking

SCHEDULE FOR NEW CONNECTION				
Ref	kV	No	Description	First Year Charges (£000s)
A	400	2	Line Connections	160
B	400	1	Mesh Section Breaker Bay	104
C	400	2	Supergrid Tx Connections	66
D	400/132	2	240MVA Transformers	364
E	132	2	100m(eg) 240 MVA Cables	52
F	132	2	Double Busbar Transformer Bays	106
	400	2	Mesh Busbar Arrangement (single switch mesh)	410
Total				1262 522

Example 2

EXTENSION OF SINGLE SWITCH MESH TO FOUR SWITCH MESH (extension to single user site)

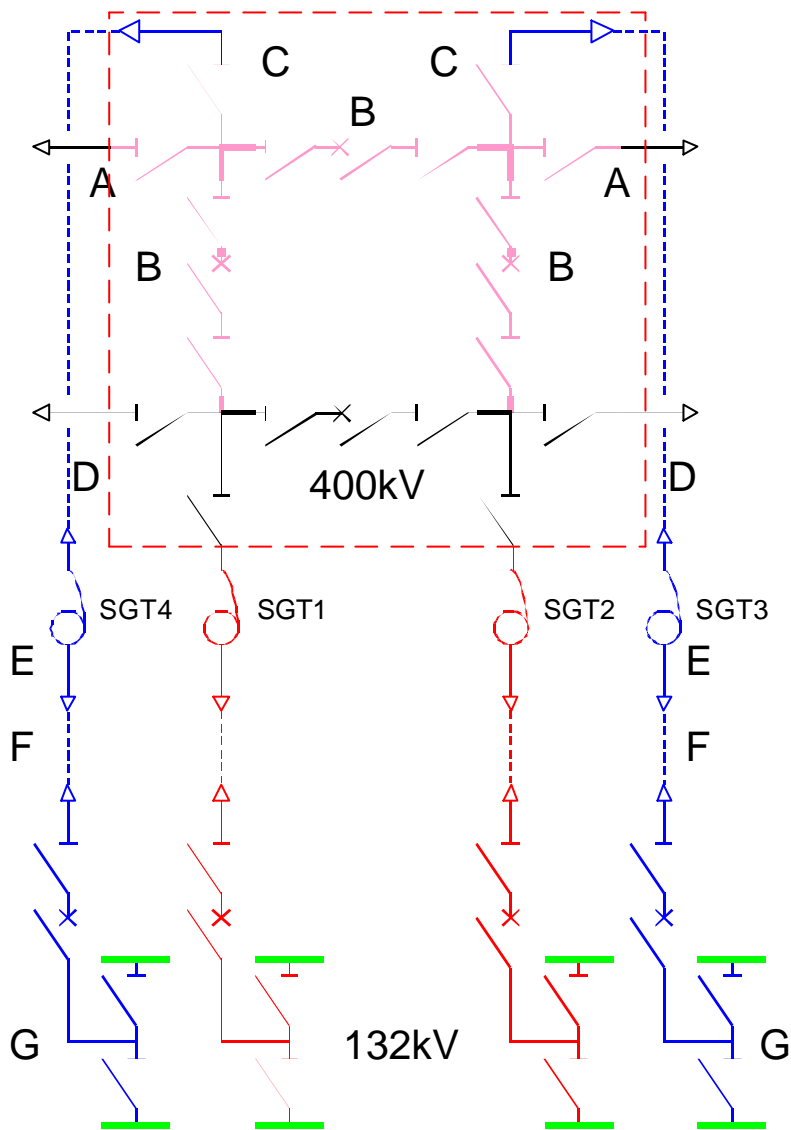

KEY:

- Existing NGC Assets
- New NGC Assets (infrastructure)
- New NGC Assets wholly charged to customer
- Existing NGC Assets wholly charged to customer
- Customer Assets
- - - Change marking

SCHEDULE FOR EXTENSION				
Ref	kV	No	Description	First Year Charges (£000s)
A	400	2	Line Connections	160
B	400	3	Mesh Section Breaker-Bay	342
C	400	2	Supergrid Tx-Connections	66
D	400	2	100M(eg) 240 MVA Cables	236
E	400/132	2	240MVA Transformers	364
F	132	2	100m (eg) 240 MVA Cables	52
G	132	2	Double Busbar Transformer Bays (inc. Breaker)	106
	400		Mesh Busbar Arrangement (2-4 Switch-Mesh)	257
Total				4553-758

Example 3

NEW 400/132KV SUPERGRID CONNECTION DOUBLE BUSBAR TYPE

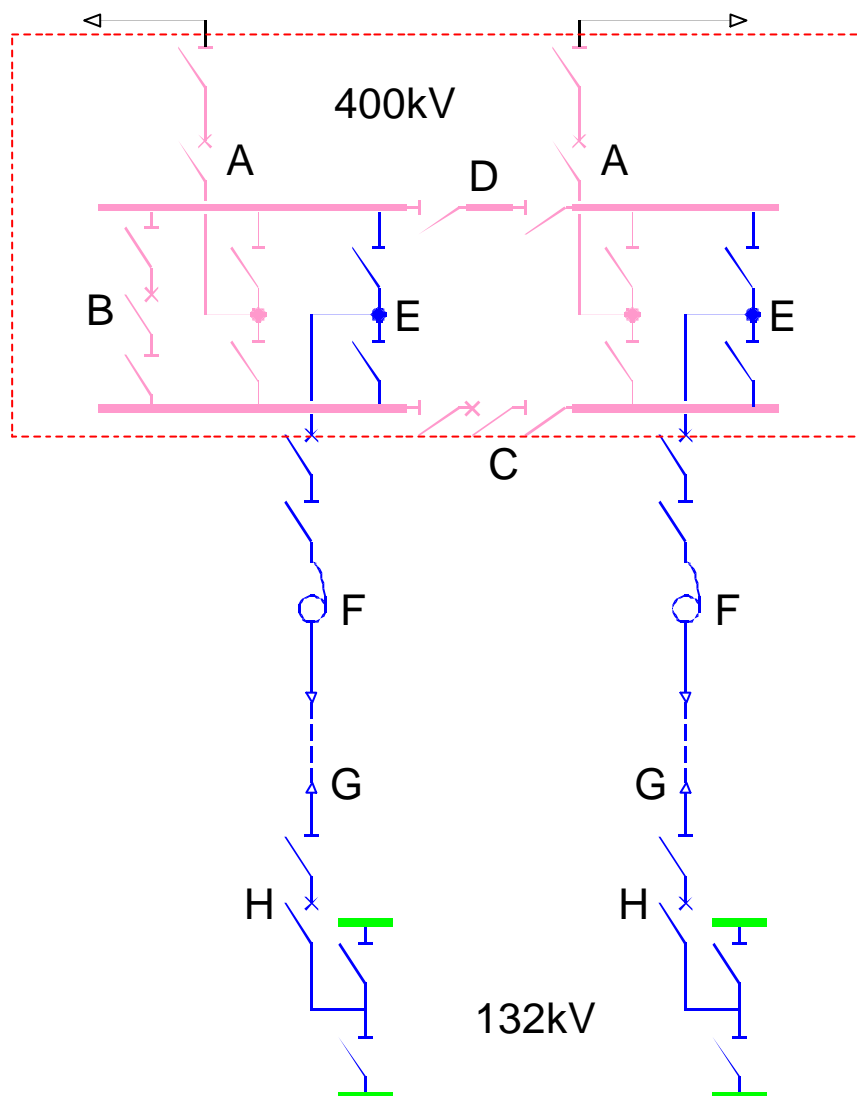

KEY:

- Existing NGC Assets
- New NGC Assets
- New NGC Assets wholly charged to customer
- Customer Assets
- - - Change marking

SCHEDULE FOR NEW CONNECTION				
Ref	kV	No	Description	First Year Charges (£000s)
A	400	2	Double Busbar Feeder Bays inc. breaker	402
B	400	4	Bus Coupler	163
C	400	4	Bus Section	144
D	400	4	Reserve Busbar Section	34
E	400	2	Double Busbar Transformer Bays inc. breaker	402
F	400/132	2	240 MVA Transformers	364
G	132	2	100m(eg) 240MVA Cables	52
H	132	2	Double Busbar Transformer Bays inc. breaker	106
Total				1667-924

Example 4

EXTENSION OF DOUBLE BUSBAR TO ACCOMMODATE THIRD TRANSFORMER (extension of single user site)

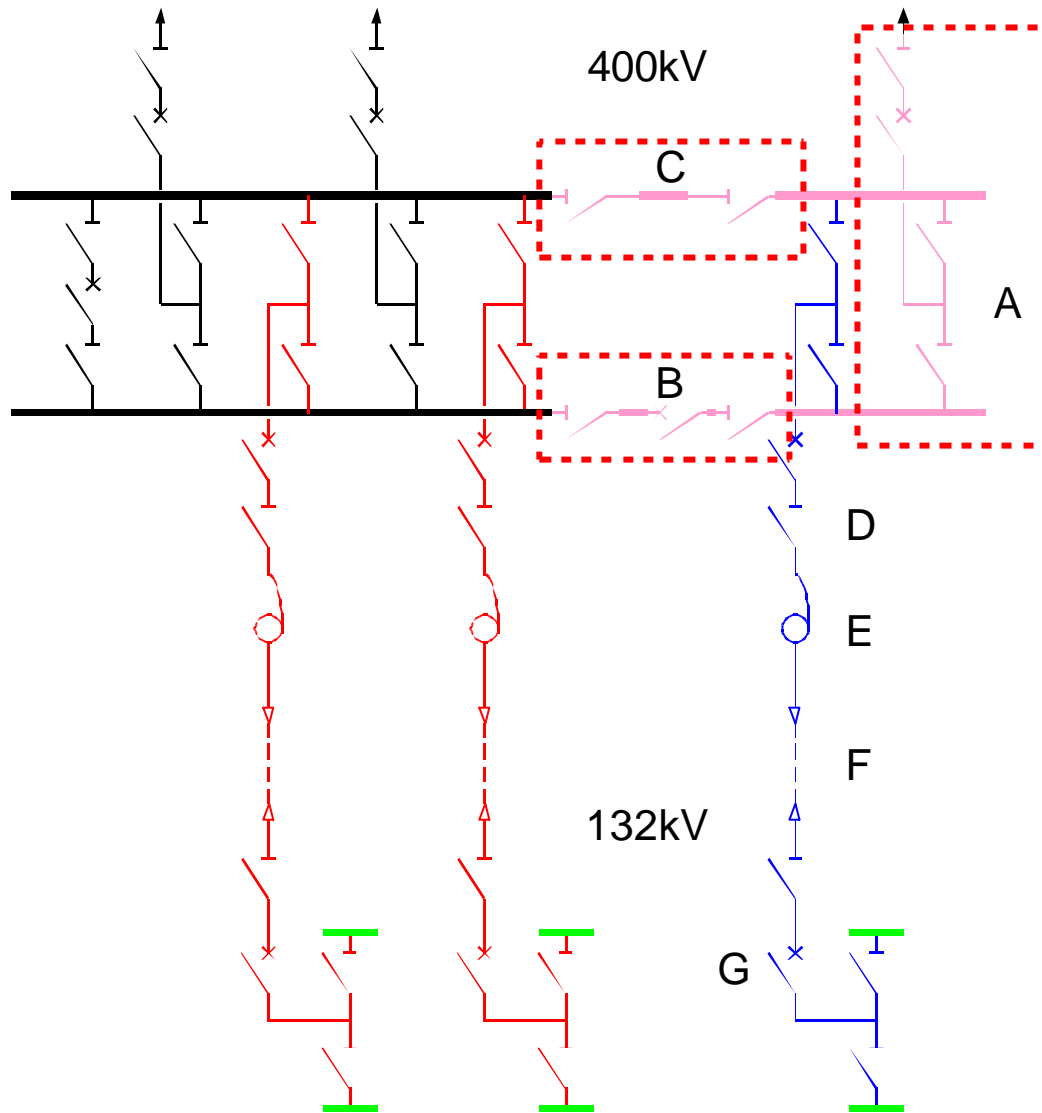

KEY:

- Existing NGC Assets (infrastructure)
- Existing NGC Assets wholly charged to customer
- New NGC Assets (infrastructure)
- New NGC Assets wholly charged to customer (plug)
- Customer Assets
- Change marking

SCHEDULE FOR EXTENSION				
Ref	kV	No	Description	First Year Charges (£000s)
A	400	4	Double Busbar Feeder Bay inc. Breaker	204
B	400	4	Bus Section	144
C	400	4	Reserve Busbar Section	34
D	400	1	Double Busbar Transformer Bay inc. breaker	201
E	400/132	1	240 MVA Transformer	182
F	132	1	100m(say) 240MVA Cable	26
G	132	1	Double Busbar Transformer Bay inc. breaker	53
Total				841 462

Example 5

NEW GENERATION CONNECTING TO AN EXISTING SUBSTATION

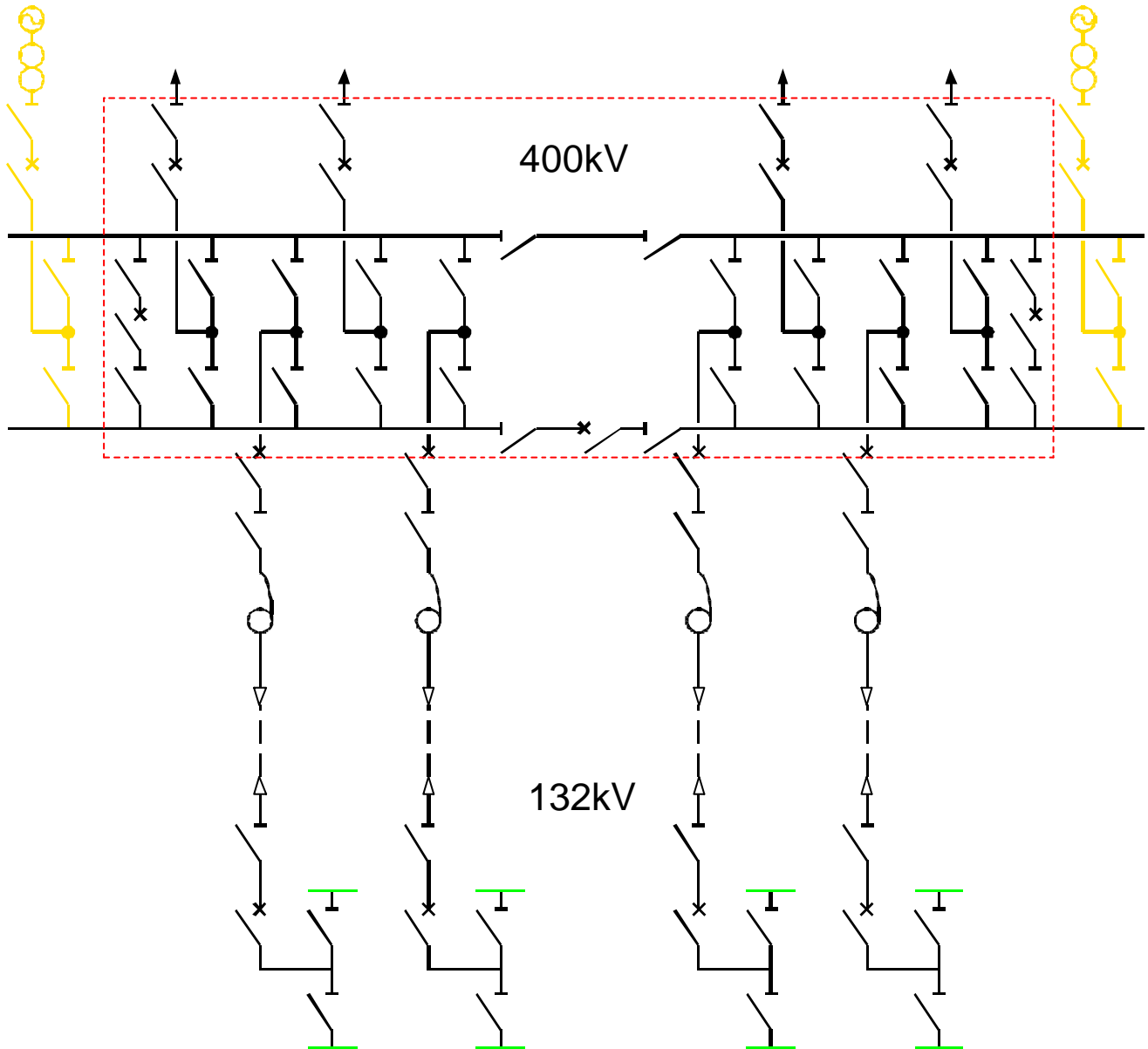

KEY:

- Existing NGC Assets
- Distribution Customer Assets
- Generation Customer Assets
- - - Change marking

SCHEDULE FOR NEW CONNECTION			
kV	No	Description	First Year Charges (£000s)
400	2	Generation Bays NGC Busbars	240

NOTE:

1. Charges to existing customers may change due to sharing of common assets with new user
2. The new customer will also take a share of the existing customer's charges if assets are shared between customers

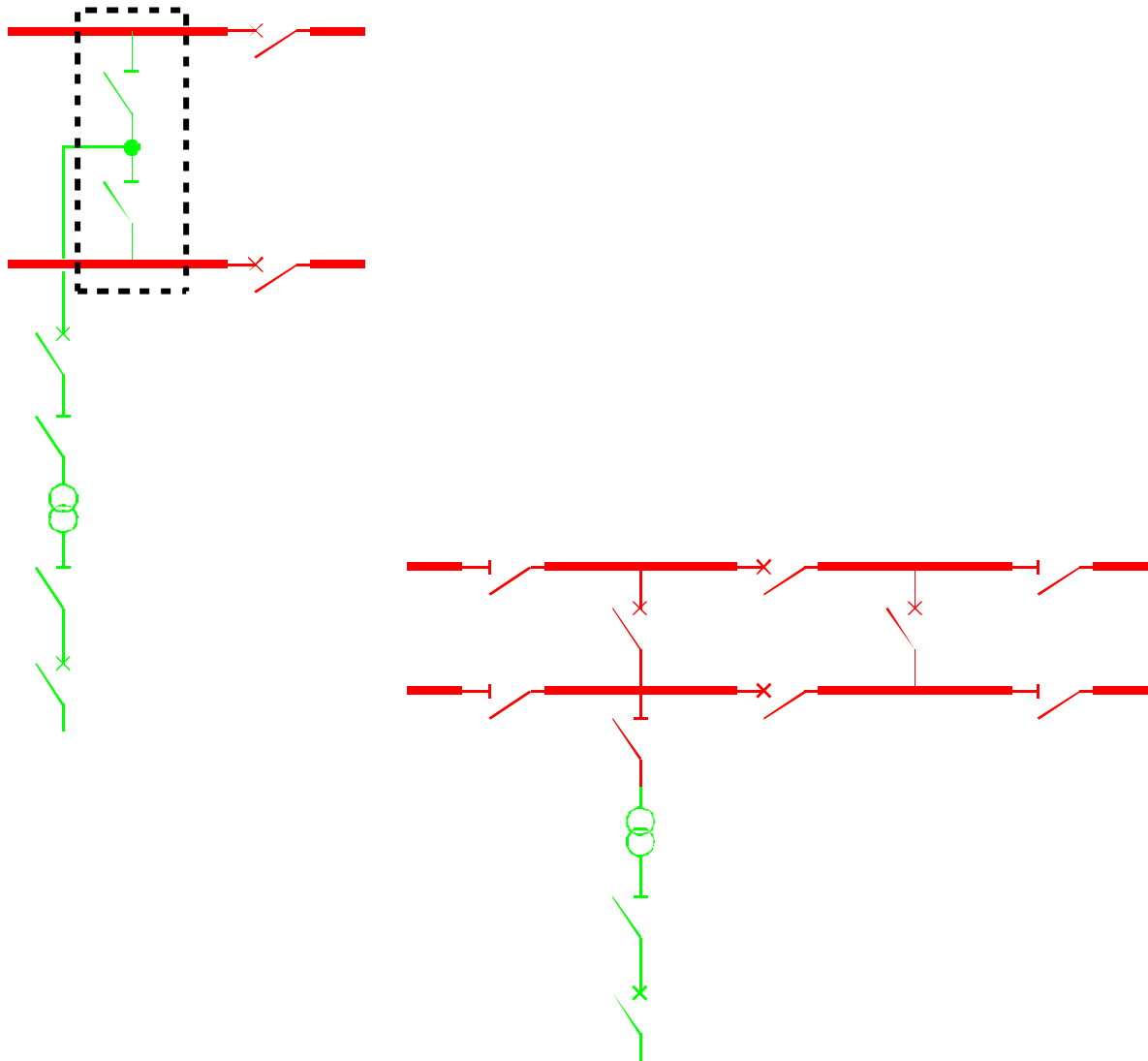

Example 6

CONTESTABLE MAINTENANCE



NON-CONTESTABLE WORK

1. Emergency Response to Operational Requirements
2. Wayleave Local Liaison
3. Maintenance Specification
4. NGC Quality Management Systems
5. Safety Management
6. Site Access

KEY:	
	Contestable maintenance package not available for these assets
	Contestable maintenance package available for these assets only
	Change marking

Appendix 10 – Proposed Changes to Chapter 10 (inc. Annexes): The Connection Asset Allocation Process

Under the proposed PLUGS connection boundary, no connection assets would be shared, hence **Chapter 10 including Annex 10A, Annex 10B and Annex 10C is completely removed.**

Appendix 11 – Proposed Changes to Glossary

Glossary

The following definitions are intended to assist the reader's understanding of this document. In the event of conflict with definitions given elsewhere, those used in the Electricity Act 1989 (as amended by the Utilities Act 2000), Transmission Licence, Grid Code, Balancing and Settlement Code and Connection and Use of System Code take precedence.

Act	The Electricity Act 1989
Authority	The Gas & Electricity Markets Authority (Ofgem)
Balancing and Settlement Code (BSC)	As defined in the Transmission Licence
Bilateral Agreement	Means, in relation to a User, a Bilateral Connection Agreement or a Bilateral Embedded Generation Agreement between National Grid and the User, as defined in Standard Condition 1 of the National Grid Transmission Licence
Bussing Point	A substation which has connected to it more than four National Grid 400 kV/275 kV circuits which are not connection assets or are not considered as Generation Only Spurs
Charging Date	As defined in the Construction Agreement of the Connection and Use of System Code (CUSC)
Commissioned	In respect of Plant and Apparatus commissioned before the Transfer Date means Plant and Apparatus recognised as having been commissioned according to the commissioning procedures current at the time of commissioning and in respect of Plant and Apparatus commissioned after the Transfer Date] means Plant and/or Apparatus certified by the Independent Engineer as having been commissioned in accordance with the relevant Commissioning Programme
Connection Entry Capacity (CEC)	As defined in the Connection and Use of System Code
Consents	In relation to any Works:- <ul style="list-style-type: none"> a) all such planning and other statutory consents; and b) all wayleaves, easements, rights over or interests in land or any other consent; or for commencement and carrying on of any activity proposed to be undertaken at or from such Works when completed c) permission of any kind as shall be necessary for the construction of the Works
Construction Agreement	An agreement entered into pursuant to Paragraph 1.3.2 of the CUSC

CUSC	The Connection and Use of System Code
Demand	Electricity consumed at sites or by equipment not owned and operated by National Grid
Depreciation Period	In relation to an NGC Asset for a particular User, the period which commences on the asset's initial effective charging date, and which expires after the appropriate duration, which unless otherwise agreed upon connection is 40 years (15 years for FMS Metering Electronics)
Directly-Connected Customer	A large, usually industrial, consumer of electricity who is directly connected to National Grid 's transmission system
Disconnect Disconnection	<p>or (a) permanent physical disconnection of the [User's Equipment] at the site of connection to the Distribution System;</p> <p>(b) permanent physical disconnection of a User's Equipment at any given Connection Site which permits removal thereof from the Connection Site or removal of all National Grid's Assets therefrom (as the case may be);</p> <p>(c) permanent physical disconnection of the User's Equipment or Equipment for which the User is responsible (as defined in Section K of the Balancing and Settlement Code) at the site of connection to the Distribution System</p>
Distribution voltage	A voltage of 132kV or below. Generally taken to be voltages lower than those defined as transmission voltages
Embedded	A direct connection to a Distribution System or the System of any other User to which Users and/or Power Stations are connected
Engineering Charge	As set out in the Statement of Use of System Charges from time to time
Exempt generator	Any generator who, under the terms of the Electricity (Class Exemptions from the Requirement for a Licence) Order 2001, is not obliged to hold a generation licence
Final Sums	As defined in the Construction Agreement
Financial Year	The period of 12 months ending on 31st March in each calendar year
Generator	A person who generates electricity under licence or exemption under the Act

Grid Code		A document prepared by National Grid in accordance with Standard Condition 7 of the Transmission Licence setting out the technical parameters for the operation and use of the transmission system and of plant and apparatus connected to the transmission system
Grid Supply Point (GSP)		A point of delivery from the National Grid Transmission System to a distribution system or Non-Embedded User
Interconnector		Means apparatus, connected to the Total System from or to an External System
Left Hand Rule		General Principle of the allocation Process (Annex 10A: Application of the Left Hand Rule)
Licence standards		Standards listed in Condition AA2 of the Transmission Licence or otherwise registered with the Authority in accordance with which National Grid is required to plan, develop, operate and maintain the transmission system
Licensable Generation		Generating plant where the party generating electricity at that generating plant is required to hold a Generation Licence
Liquidated Damages		The sums specified in the Construction agreement
Mandatory Agreement	Services	An agreement between National Grid and a User to govern the provision of and payment for Mandatory Ancillary Services
Modification		Any actual or proposed replacement, renovation, modification, alteration, or construction by or on behalf of a User or National Grid to either that CUSC Party's Plant or Apparatus or the manner of its operation which has or may have a Material Effect on another CUSC Party at a particular Connection Site
National Grid Assets		The Plant and Apparatus owned by National Grid necessary to connect the User's Equipment to the National Grid Transmission System at any particular Connection Site in respect of which National Grid charges Connection Charges (if any) as listed or identified in [Appendix A] to the Bilateral Agreement relating to each such Connection Site
National Transmission System	Grid	The system consisting (wholly or mainly) of high voltage electric lines owned or operated by National Grid and used for the transmission of electricity from one Power Station to a sub- station or to another Power Station or between sub-stations or to or from any External Interconnection and includes any Plant and Apparatus and meters owned or operated by National Grid in connection with the transmission of electricity but does not include any Remote Transmission Assets

NETA “Go-live date”	Means the date designated by the Secretary of State for the start of trading under the BSC; and unless otherwise required, means 00:00 hours on that date
Ownership boundary	Shall be the boundary defined by Paragraph 1.7 in this document
Power Station	As defined in the Grid Code as: “an installation comprising one or more Generating Units (even where sited separately) owned and/or controlled by the same Generator, which may be reasonably considered as being managed as one Power Station.”
Public Distribution System Operator	Any holder of a distribution licence who was the holder, or is a successor to a company which was the holder of a Public Electricity Supply Licence relating to the distribution activities in England and/or Wales on the CUSC Implementation Date
Reasonable Charges	Reasonable cost reflective charges comparable to charges for similar services obtainable in the open market
Replacement Period	In relation to an NGC Asset, the period commencing on the date on which such NGC Asset is or was originally Commissioned, after which it is assumed for accounting purposes such NGC Asset will need to be replaced, which shall be 40 years unless otherwise agreed between the parties to a Bilateral Agreement and recorded in the relevant Bilateral Agreement

Retail Price Index		Means the general index of retail prices published by the Office for National Statistics each month in respect of all items or: (a) if the said index for any month in any year shall not have been published on or before the last day of the third month after such month such index for such month or months as the parties hereto agree produces as nearly as possible the same result shall be substituted or in default of the parties reaching agreement within six weeks after the last day of such three month period then as determined by a sole Chartered Accountant appointed by agreement by both parties or in the absence of agreement on the application of either party by the President of the Electricity Arbitration Association who shall act as an expert and whose decision shall be final and binding on the parties; or (b) if there is a material change in the basis of the said index, such other index as the parties agree produces as nearly as possible the same result shall be substituted or in default of the parties reaching agreement within six weeks after the occurrence of the material change in the basis of the said index then as determined by the sole Chartered Accountant appointed by agreement by both parties or in the absence of agreement on the application of either party by the President of the Electricity Arbitration Association who shall act as an expert and whose decision shall be final and binding on the parties
Security Standard		National Grid's Transmission System Security and Quality of Supply Standard
Supplier		A holder of an electricity supply licence
Total System		Has the meaning given to that expression in the Electricity Generation Licence i.e. "...the transmission and distribution systems of all authorised electricity operators which are located in England and/or Wales"
Trading Party		As defined in the Balancing and Settlement Code
Transfer date		31 st March 1990
Transmission Licence		The licence granted to National Grid under Section 6(1)(b) of the Act
Transmission Activity	Owner	The function of National Grid's Transmission Business as defined in the Transmission Licence
Transmission system		The system which consists (wholly or mainly) of high voltage lines and electrical plant owned or operated by National Grid and used for the transmission of electricity from one generating station to a sub-station or to another generating station or between sub-stations or to any Interconnector

Transmission voltage	Voltages above 132kV - usually 275kV and 400kV
User	A party that connects to or makes use of the National Grid Transmission System
Utilities Act 2000	Electricity Act 1989, as amended by Utilities Act 2000