

nationalgrid

THE POWER OF ACTION

Electricity SO Incentives
Initial Proposals for 1st
April 2011

UK Electricity Transmission
November 2010

Electricity SO Incentives: Initial Proposals for 1st April 2011

Issue 1 - National Grid, 24th November 2010

Executive Summary

1. This document sets out National Grid's Initial Proposals for implementing a two-year electricity system operator incentive scheme commencing 1st April 2011.
2. A multi year scheme will, amongst other factors, incentivise National Grid to take a longer term view to SO costs, lead to greater cost transparency and reduce the ongoing administrative burden involved with the development of SO incentive schemes.
3. Following the implementation of the SO incentive scheme for 2010/11, the approach to developing electricity SO incentives was reviewed (the SO Review) to determine whether the models and modelling approach used by National Grid were suitable for application to multi-year schemes.
4. The SO Review comprises three phases. The first phase involved the review of National Grid's approach to modelling and the modelling tools employed to forecast system operator costs to determine their suitability for developing incentive schemes of greater than one year's duration. This was undertaken by Ofgem, with support from Frontier Economics (hereafter referred to as Frontier). The second phase involved National Grid acting on the recommendations from Phase 1 with regard to developments to its models, modelling approach and the design and governance structures of a multi-year incentive scheme. The third phase, currently underway, involves the assessment of National Grid's proposed changes against the recommendations from Phase 1.
5. The proposals set out in this document are based on Ofgem's key preliminary conclusions from Phase 1, which, in the light of the findings of Frontier's report was that, while developing and implementing a multi year incentive scheme is inherently difficult, significant improvements can be made to NGET's methodology (including its models and modelling approach) in order to develop a scheme that can be set for multiple years and provides incremental benefits that can be passed on to consumers.
6. The methodology being proposed takes into account the impact of unpredictable and uncontrollable external factors affecting National Grid's cost base by adjusting the incentive target at the end of the scheme period for these factors. This methodology ensures that National Grid's performance is measured by how efficiently it carried out its actions taking into account the actual external factors it faced.
7. National Grid has, as per Ofgem's preliminary conclusions, undertaken a number of improvements to its energy model, including how the inputs into the models are forecast and the relationships, within the models, between the drivers of NGET's costs and the costs themselves. National Grid is also in the process of replacing its current suite of constraints models with a single fundamentals model that considers the GB-wide system as a whole.
8. This revised approach to incentivisation does not feature the agreement of a forecast of IBC prior to the start of the scheme. Instead, it requires agreement between National Grid and Ofgem on models and model input data, so that modelled 'target costs' can be calculated on a routine basis through the scheme.
9. The proposals represent a significant expansion of the current approach to adjusting incentivised cost targets, which is based on the use of a single automatic adjuster (the Net Imbalance Adjustment, or NIA) and additional 'ad-hoc' adjusters to manage specific areas of risk as appropriate (such as the magnitude and direction of flows across the interconnector to France).

10. Whilst the proposed approach to incentivisation does not feature an agreed forecast cost target, a forecast of IBC, and an associated Balancing Services Use of System (BSUoS) cost forecast, will be issued by National Grid in early 2011.
11. National Grid has procured a new piece of software to assist it in the modelling of constraint costs. As this software is currently being implemented, the information in this document relating to constraint modelling is more conceptual than that presented for the other energy-based models. As such, an addendum to this document will be issued on 13th December once the constraint modelling detail has been finalised.
12. It should be noted that Ofgem's conclusions from phase 3 of the SO Review – which relates to the examination of National Grid's proposed methodology, including its models and modelling approach – may require further development of the proposals contained within this document if an SO incentive scheme covering multiple years is to be agreed.
13. National Grid notes the significant shift in incentivisation that these proposals represent, and encourages the industry to participate in this Initial Proposals consultation to ensure that their views can be taken into account in the Final Proposals for the next incentive scheme. This is particularly important given the changes to the approach that are being proposed.
14. Responses to this consultation will be considered by Ofgem, along with its conclusions following phase three of the SO Review, when developing Final Proposals for a two-year electricity SO incentive scheme to be implemented from 1st April 2011. These should be available by the end of February 2011.
15. **Responses to these Initial Proposals should be sent to soincentives@uk.ngrid.com by 22nd December 2010.** All responses received will be placed on our website (unless explicitly requested not to) and will be sent in full to Ofgem.

Associated Documents:

16. This Initial Proposals document should be read in conjunction with the following documents, available on the National Grid website:

<http://www.nationalgrid.com/uk/Electricity/soincentives/docs/>

- BSIS 2011/13 Initial Proposals: Appendices
- BSIS Reference Document

Contents

1. Overview	5
1.1 An Introduction to National Grid	5
1.2 The Balancing Services Incentive Scheme (BSIS)	5
1.3 The SO Incentive Review (SO Review)	5
1.4 Next Steps.....	7
2. The New Approach to Incentivisation	9
2.1 The current approach: Incentivising 'total costs'	9
2.2 The proposed approach	10
2.3 Maintaining appropriate incentivisation	11
2.4 Assessment of BSIS model inputs and drivers	14
3. Modelling.....	26
3.1 Energy Model Development.....	26
3.2 Constraints Model Development.....	57
4. Scheme Design and Governance	68
4.1 Introduction.....	68
4.2 Scheme Structure.....	68
4.3 Proposed scheme profile	71
4.4 Governance.....	71
5. Further Work.....	78
5.1 Transition to a Longer Term Scheme.....	78
6. Further Information	82
7. Contact Us	82

1. Overview

1.1 An Introduction to National Grid

17. National Grid Electricity Transmission is the National Electricity Transmission System Operator (NETSO) for England, Scotland and Wales, defined hereon in as National Grid.
18. Under the Transmission Licence, National Grid is obliged to perform Balancing Services Activities (BSA), which are defined as the operation of the transmission system and the procurement and use of Balancing Services required for reliable operation of the transmission system.
19. National Grid is obligated under the terms of its Transmission Licence to balance the system in a safe, efficient, economic and co-ordinated manner. The application of financial incentives encourages National Grid to invest in systems and resources to ensure BSA costs and risks are economically and efficiently managed and that innovative ideas and procedures are developed to reduce costs in return for a share of any savings delivered.

1.2 The Balancing Services Incentive Scheme (BSIS)

20. BSIS is designed to deliver financial benefits to the industry and consumers via reductions in the costs or minimising risk associated with operating the electricity transmission network. The current BSIS incentive format has been in place since the implementation of the New Electricity Trading Arrangements (NETA) in 2001 and has covered a one year period.
21. During the process of setting an SO incentive scheme from 1st April 2010, National Grid and Ofgem sought to agree a longer term scheme. However, following concerns regarding National Grid's analysis and modelling work, Ofgem were only able to propose a scheme of the usual duration of one year.
22. Therefore following the 2010/11 BSIS scheme consultation process, Ofgem established an electricity SO incentive review¹ with a view to implementing a more effective SO incentive scheme for a period greater than one year. The premise being that such a scheme would, amongst other factors, incentivise National Grid to take a longer term view to SO costs, lead to greater cost transparency and reduce the ongoing administrative burden involved with the development of SO incentive schemes.

1.3 The SO Incentive Review (SO Review)

23. The SO Review was proposed by Ofgem following concerns regarding the current approach to the setting of the incentive and the suitability of National Grid's analysis and modelling for the development of a longer term scheme. National Grid therefore agreed to work with Ofgem to review the scheme forecast methodology via a licence condition². The objectives of the review were to develop a methodology for a multi-year SO incentive scheme, to develop modelling tools to support the methodology and to develop a workable approach for application to an SO incentive scheme commencing 1st April 2011.
24. The SO review comprises three phases. The first phase involved the review of National Grid's approach to modelling and the modelling tools employed to forecast BSIS costs. This was undertaken by Ofgem, with support from Frontier.

¹ The text can be found in the Final Proposals for the scheme commencing 1st April 2010:
http://www.ofgem.gov.uk/Markets/WhlMkts/EffSystemOps/SystOpIncent/Documents1/SO%20Final%20Proposals%20Consultation%20Document_elec%20only.pdf

² The licence condition text can be found here:
<http://www.ofgem.gov.uk/Markets/WhlMkts/EffSystemOps/SystOpIncent/Documents1/Scan001.pdf>

25. Ofgem subsequently published its Preliminary Conclusions following Phase 1³ in July 2010, based upon Frontier's findings⁴. In its Phase 1 Report, Ofgem concluded that an appropriate BSIS methodology should ensure that NGET's performance is measured by how efficiently it carried out its actions taking into account the actual external factors it faced. Further information on the phase 1 conclusions and the outputs from phase 2 are detailed below.
26. Following publication of Ofgem's Preliminary Conclusions following Phase 1 document, National Grid published a letter on 27 July 2010⁵ setting out its broad agreement with Ofgem's proposals for a two year scheme and the SO review as a whole.

1.3.1 Summary of Phase 1 conclusions and key outcomes of Phase 2 of the SO Review

High-level conclusions of Phase 1 of the SO Review

27. In the Preliminary Conclusions following Phase 1 document, Ofgem concluded that, while developing and implementing a multi year incentive scheme is inherently difficult, significant improvements can be made to NGET's methodology (including its models and modelling approach) in order to develop a scheme that can be set for multiple years and provides incremental benefits that can be passed on to consumers.

Scheme structure

28. Ofgem concluded that the scheme to be put in place from 1st April 2011 should be of similar format to previous schemes. That is, it envisaged that the new scheme would:
 - be a bundled scheme, incentivising National Grid on energy and constraint costs⁶;
 - include a target level of external SO costs against which National Grid's performance should be measured; and
 - include risk-setting parameters (upside and downside sharing factors, a profit cap and a loss floor).

Modelling approach

29. Ofgem proposed that National Grid develop a BSIS methodology which incentivises the SO on the costs and cost drivers that are within its control. To achieve this methodology, Ofgem concluded that a number of variables which form inputs to BSIS cost forecast models should be input to those models *Ex-Post* as opposed to *Ex-Ante* as they were external factors beyond National's Grid's ability to control and/or forecast. Ofgem concluded that this approach should reduce the level of risk on National Grid and therefore reduce the need for a scheme dead-band, whilst also enabling an increased incentive to be placed on National grid through increasing the magnitude of the sharing factors, cap and floor.

Ofgem's conclusions with regard to National Grid's modelling approach

30. Ofgem concluded that National Grid's energy models need to be improved, including updating its inputs and calculations to allow their application to multi-year incentive schemes; and that National Grid's separate E&W and Scotland constraint models need to be replaced with a single GB-wide fundamentals model, to enable an unconstrained and constrained schedule, based on the merit order across GB, to be derived on an internally consistent basis. These developments, more specifically described in Section 3, are summarised below.

³ Ofgem's Phase 1 Preliminary Conclusions can be found at: <http://www.ofgem.gov.uk/Markets/WhlMkts/EffSystemOps/SystOpIncent/Documents1/Phase%201%20recomendations%20doc%204.pdf>

⁴ Frontier's findings can be found within Ofgem's Phase 1 Preliminary Conclusions document: <http://www.ofgem.gov.uk/Markets/WhlMkts/EffSystemOps/SystOpIncent/Documents1/Frontier%20final%20report.pdf>

⁵ The letter can be found at: <http://www.nationalgrid.com/NR/rdonlyres/86C9C1E9-A2EF-4637-B70A-88C8E5B85597/42402/BSISSORReviewNGETLetter27July2010.pdf>

⁶ The scheme should continue to also include black start costs and transmission losses.

Development of the Energy Model

31. The overall Energy Model and its component parts have been redeveloped and extended for application to a 2 year scheme. To deal with potential future schemes of longer than 2 years, National Grid has ensured that all the component models have been designed with enough flexibility to cope with the additional data requirements.
32. National Grid reviewed each component model in turn:
 - Energy Imbalance
 - Margin Volume
 - Margin Price
 - Fast Reserve
 - Frequency Response
 - Footroom
33. To maximise the benefit of the model review during phase 2, National Grid has focused its investigations on cost drivers that are known to have an impact on modelled costs.

Procurement of a new Constraints Model

34. National Grid has procured a new software tool, Plexos, which in addition to replacing its current suite of in-house constraint models, also enables the modelling of generation despatch decisions using plant characteristics and market fundamentals. For the purposes of developing an incentive from 1st April 2011, a boundary-based approach to modelling the transmission network has been adopted. This boundary-based approach is intended to represent the transmission network as a series of zones corresponding to existing and potential future constraint boundaries.
35. The implementation of Plexos that will be used to support the scheme from 1st April 2011 is known as the 'interim solution' – in the longer-term, it is anticipated that the 'enduring solution' Plexos implementation will feature a full modelled representation of the transmission network.
36. To guard against the risk that the procured software will not be available in time to support the operation of the scheme, National Grid has also developed a 'contingency' model based on a full boundary model representation of the GB transmission network.

1.3.2 Phase 3 of the SO Review

37. Phase 3 of the SO Review relates to the examination of National Grid's proposed methodology produced in Phase 2, including its models and modelling approach, to determine its appropriateness for application to an SO incentive scheme covering at least two years.
38. The proposals developed by National Grid during Phase 2 of the SO Review have been summarised in a report to Ofgem and Frontier, for consideration during Phase 3. Phase 3 is being led by Ofgem, with support from Frontier. Frontier will provide its views to Ofgem and National Grid on National Grid's Phase 2 proposals and, where necessary, suggest further developments to support the delivery of a multi-year incentive scheme starting on 1st April 2011.
39. It should be noted that, while the Phase 2 report explored numerous issues associated with National Grid's proposed approach to its energy model, the report did not fully explore National Grid's proposed approach to constraints. Work continues with regard to the implementation of the constraints modelling solution as highlighted above. Accordingly, whilst Phase 3 of the SO Review for energy is currently underway, Phase 3 for constraints won't commence until 6th December when National Grid's constraint modelling solution is handed over to Ofgem. An addendum to this document will be issued on 13th December to allow for industry comment on the constraint proposals within the Initial Proposals consultation period.

1.4 Next Steps

40. Unlike previous years, this Initial Proposals document does not include proposals for the parameters of the incentive scheme or a forecast of the Incentivised Balancing Cost (IBC). Instead, it seeks views on National Grid's proposals for a two-year incentive scheme in terms of

Section 1 Overview

the scheme design and governance; models; modelling approach and the appropriate treatment of model inputs that will be required to support the delivery of such a scheme.

41. Work continues to develop constraint modelling capability using the Plexos model. Accordingly, the constraint modelling section of this report sets out the principles we will apply in our constraints modelling process. An addendum to this document, which presents National Grid's constraint modelling proposals in more detail, will therefore be published on 13th December following submission of our constraint modelling proposals to Ofgem.
42. A workshop is being planned on 8th December 2010 in London (for a 14:30 hours start), focusing on key themes within this Initial Proposals document. To register to attend the workshop, please e-mail soincentives@uk.ngrid.com. Additionally, National Grid will be offering the opportunity to discuss the proposals on a bilateral basis for interested parties.
43. National Grid seeks and values industry engagement in the Initial Proposals consultation process and encourages interested parties to offer their views, particularly given the changes to the scheme that are being proposed. Feedback from the consultation process will be used, in conjunction with the conclusions and further developments enacted under Phase 3 of the review, to inform Ofgem's Final Proposals for an SO incentive scheme starting 1st April 2011.
44. **Responses to these Initial Proposals should be sent to: soincentives@uk.ngrid.com by 22nd December 2010.**

2. The New Approach to Incentivisation

2.1 The current approach: Incentivising ‘total costs’

45. The current approach to incentivising National Grid’s system operator performance involves the agreement of a forecast target level for bundled energy and constraint costs, along with transmission losses and black start. This is done almost entirely on an Ex-Ante basis, although an automatic adjustment mechanism (the Net Imbalance Adjustment; or NIA) is employed to recognise that National Grid has no influence over the sum of individual parties’ imbalance that it has to resolve. The forecast cost (the IBC) is the target against which National Grid’s out-turn costs are compared.
46. National Grid prepares a forecast of IBC for the following Financial Year, for inclusion in its Initial Proposals process, around November of each year. This forecast can be subject to a number of iterations through the process of agreeing the incentive scheme prior to formal agreement being enshrined in its transmission licence, usually during the March prior to scheme start (at which point it becomes fixed for the duration of the scheme).
47. The table below shows the scheme parameters for 2010/11 alongside those for previous schemes back to the implementation of the New Electricity Trading Arrangements (NETA) in 2001. For the 2010/11 scheme, National Grid will receive no payment when outturn Incentivised Balancing Costs are within the dead band between £550m and £605m. These cost levels are subject to downward adjustment for two pre-specified areas of uncertainty – firstly regarding the level of new generation capacity connecting in Scotland; and secondly regarding the magnitude and direction of flows across the interconnector to France during a specific transmission outage. When outturn costs are below (or above) the dead band then NGET will receive (or pay) 15% of the difference, subject to a maximum of £15m. Information regarding the level of adjustment to be made will be sent to Ofgem by 30th November 2010.

	Target £m	Sharing factors		Cap £m	Floor £m	Actual Costs £m	NIA ⁷ £m	National Grid share £m
		Upside %	Downside %					
2001/02	382	40	12	46.3	-15.4	263.0	58.2	46.3
2002/03	367	60	50	60	-45	285.6	-51.7	48.6
2003/04	340	50	50	40	-40	280.8	0.43	32.2
2004/05	320	40	40	40	-40	289.2	-11.4	12.2
2005/06	378	40	20	40	-20	427.2	-104	-4.0
2006/07	n/a	n/a	n/a	n/a	n/a	495	n/a	n/a
2007/08	430-445	20	20	10	-10	451	-128	-1.2
2008/09	530-545	25	25	15	-15	827	-94	-15
2009/10	571.43- 601.43	25	15	15	-15	416	-261	15
2010/11	550-605	15	15	15	-15			

Table 1: Summary of historic BSIS parameters

48. A glance at both the target and outturn values highlights the relative stability of SO costs between 2001/02 and 2004/05. Since the introduction of the British Electricity Transmission and Trading Arrangements (BETTA) in 2005, SO costs have exhibited more volatility. This volatility has often been due to factors beyond National Grid’s control such as changes in the wholesale price for electricity relative to that which was assumed when the final scheme target Incentivised Balancing Cost was set. Whilst NIA has served to limit National Grid’s exposure to some of the volatility with regard to energy imbalance costs, there is currently no similar mechanism to adjust other cost components to manage similar volatility.

⁷ The NIA calculation changed in 2009/10

Section 2 The New Approach to Incentivisation

49. This volatility has been witnessed between the Initial Proposals and Final Proposals stages of previous incentive schemes, as well as during the schemes themselves, making agreement of Ex-Ante scheme targets more difficult. To try and manage the impact of this volatility, recent incentive schemes have featured dead-bands around a cost target and lower sharing factors to mitigate some of the risk presented by the increasing uncertainty surrounding the forecast level of IBC.
50. Further, recent schemes have also seen the introduction of additional adjustment mechanisms to deal with specific issues, such as those established for the 2010/11 BSIS to deal with uncertainty surrounding the additional level of generation connecting in Scotland⁸ and flows across the Interconnexion France-Angletère (IFA)⁹.

2.2 The proposed approach

51. The proposed approach to setting an incentive scheme is to place appropriate incentives on National Grid to deliver efficiencies in areas over which it has some control. It is also designed to avoid the need to form a view of volatile, difficult to forecast parameters prior to the scheme commencing.
52. Under the proposed approach, no target is agreed prior to scheme start, however, the relationships between the model inputs are defined and agreed at this stage. By adjusting the incentive target at the end of the scheme, the scheme takes into account the impact of unpredictable and uncontrollable external factors affecting National Grid's cost base.
53. Unpredictable and uncontrollable external factors affecting National Grid's cost base include those volatile, difficult to forecast parameters, such as fuel prices, wholesale electricity prices and Net Imbalance Volume (NIV), which is then combined with relevant forecast (Ex-Ante) data for other model inputs and run through National Grid's models to give an Ex-Post target cost calculation for Incentivised Balancing Costs.
54. This moving target approach is illustrated graphically below:

		Scheme duration (months)							
		1	2	3	4	5	6	...	24
Month	0	Yellow	Yellow	Yellow	Yellow	Yellow	Yellow	White	Yellow
	1	Blue	Yellow	Yellow	Yellow	Yellow	Yellow	White	Yellow
	2	Blue	Blue	Yellow	Yellow	Yellow	Yellow	White	Yellow
	3	Blue	Blue	Blue	Yellow	Yellow	Yellow	White	Yellow
	...	White	White	White	White	White	White	White	Yellow
	24	Blue	Blue	Blue	Blue	Blue	Blue	Blue	Blue

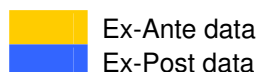

Table 2: Overview of Ex-Post timings

55. The diagram shows a scheme of 24 months' duration along the x-axis; and 24 months of reporting down the y-axis. Month 0 represents the period prior to scheme start. At this point, National Grid would have a full set of data required to model Incentivised Balancing Costs for the duration of the proposed incentive scheme, and so would be able to produce a forecast cost for the duration of the scheme (and importantly a

⁸<http://www.ofgem.gov.uk/Markets/WhIMkts/EffSystemOps/SystOpIncent/Documents1/Ian%20Marlee%20Generation%20Sideletter%20250310%20Updated.pdf>

⁹<http://www.ofgem.gov.uk/Markets/WhIMkts/EffSystemOps/SystOpIncent/Documents1/Ian%20Marlee%20IFA%20SideLetter%20250310.pdf>

Section 2

The New Approach to Incentivisation

forecast BSUoS cost). However, unlike the current scheme, the forecast cost target at this point would not be a defining parameter of the scheme.

56. Each month, the forecast data for the volatile, difficult to forecast parameters would be overwritten with out-turn data, then the combined forecast/out-turn data would be fed through the models to derive a modelled 'target' level of Incentivised Balancing Costs. The actual costs incurred by National Grid will be compared against this target cost to determine scheme performance.
57. National Grid's forecast of its out-turn costs and the end-of-scheme target will be updated on a monthly basis, with the overall scheme cost target known after the end of month 24. At this point, comparison with out-turn costs will give National Grid's final performance under the scheme.
58. As the methodology being proposed takes into account the impact of unpredictable and uncontrollable external factors affecting National Grid's cost base by adjusting the incentive target at the end of the scheme period for these factors, it should be possible to put stronger incentives on National Grid to reduce SO costs and also to ensure that National Grid's performance is measured by how efficiently it carried out its actions taking into account the actual external factors it faced.

Question 1: To what extent do you think that the proposed approach to incentivisation, with the use of Ex-Post data for volatile, difficult to forecast parameters, will result in more appropriate incentivisation of National Grid's system operator activities?

2.3 Maintaining appropriate incentivisation

59. Critical to the success of the approach outlined in section 2.2 is determining the relationships between the various factors that influence costs and then categorising the inputs as those that can (or can not) be reasonably be forecast, as well as determining which of these inputs are (or are not) under National Grid's control. Where National Grid does not have any control of the inputs it may still be able to take actions that result in reduced costs.
60. It is important to strike an appropriate balance between insulating National Grid from volatile parameters over which it has little or no control over (using 'Ex-Post' out-turn data in models), and incentivising it to deliver efficiencies where it does have a measure of control (using 'Ex-Ante' forecast data in models). The remainder of section 1 considers this in detail.

2.3.1 Categorisation of inputs

61. The extent to which the drivers of system operation costs can be controlled or forecast to enable effective incentivisation as part of a system operator incentive scheme is fundamental to whether they should be considered as Ex-Ante or Ex-Post inputs to BSIS models.
 - **Ex-ante inputs** will be set prior to scheme start in the same way as the current scheme. The same dataset will be used whenever the models are run throughout the scheme and would not normally be updated as the scheme progresses (except under specific agreed circumstances); and
 - **Ex-post inputs** will be collated on a monthly basis and combined with the Ex-Ante dataset, to be run through the models to determine the target level of costs that National Grid should be incentivised against.

2.3.2 Criteria to assess the treatment of modelled parameters

62. To investigate the extent to which National Grid can be appropriately incentivised, National Grid's ability to forecast or control cost drivers is considered, with particular

Section 2

The New Approach to Incentivisation

reference to the potential mechanisms it can use to influence them. The process of determining the extent to which National Grid can both forecast and control existing cost drivers will also be important when determining whether a new cost driver should be treated on an Ex-Ante or Ex-Post basis in BSIS models.

National Grid's ability to forecast inputs to BSIS models

63. National Grid's ability to forecast inputs at lead times of up to 24 months (and potentially beyond) depends on a number of factors. For each input, National Grid's ability to forecast will be considered as follows:

Measure	Detail
Availability of data	Inputs may be based on submitted data (which is likely to have a range of certainty associated with it) or on collected data from other sources (including out-turn data). It is assumed that data is already available to National Grid – where additional data is required, the potential cost of procuring such data is not explicitly considered.
Volatility of drivers	Inputs may be based on plant parameters, and hence be reasonably stable, or they may be based on economic fundamentals/market behaviour (such as fuel prices), with the potential to exhibit significant volatility. Assessment of volatility is assumed to apply for 24 months unless otherwise stated.
Applicability of historic data trend analysis	Inputs may be driven by known behaviours studied over a period of time, such as demand forecasts, and hence be forecast with a good degree of certainty. Alternatively, they may be driven or influenced by one-off/exceptional events, such as significant prolonged plant failure, which might not normally be considered as part of a 'reasonable' forecast.

Table 3: Generic assessment criteria for National Grid's ability to forecast inputs

64. The extent to which each measure contributes to National Grid's ability to forecast an input is assessed to give an overall forecast confidence, as follows:
- **None:** National Grid has no ability to forecast the input
 - **Low:** National Grid's ability to forecast the input is limited, for example due to lack of data, volatility of the input or lack of historic trends
 - **Medium:** National Grid's ability to forecast the input is reasonable, through a combination of data availability and either low volatility or the presence of usable historic trend analysis
 - **High:** National Grid's ability to forecast the input is good, through availability of data and known behaviours

National Grid's ability to control inputs to BSIS models

65. National Grid has a number of tools at its disposal to manage or influence the requirement for, and cost of, the actions it takes for system operation purposes. The greater the degree of control, the more suitable a tool is likely to be for incentivisation. However, not all tools are applicable to all model inputs. Depending on the model input, there may be sub-components that have varying degrees of control, and hence varying suitability for incentivisation. Key tools that National Grid considers it can use are as follows:

Tool	Extent of National Grid control	Areas for incentivisation
Balancing Mechanism (BM)	National Grid could be seen as a price taker in the BM, although its actions as sole counter-party can influence submitted prices in subsequent settlement periods. Also, it can trade-off delivery of required volume of actions between pre-	Trading strategy

Section 2

The New Approach to Incentivisation

	and post-gate closure to deliver value.	
Trades	National Grid can enter into forward trades with counterparties to buy or sell energy for 'energy' or 'system' reasons.	Trading strategy; Contracting approach
Balancing Services contracts	National Grid can enter into agreements with counterparties for the provision of ancillary services or to manage power station output levels.	Trading strategy; Contracting approach; Development of ancillary services; Enhancing pool of available service providers
Transmission system planning/ operation	National Grid can keep its approach to planning and operating the national electricity transmission system under review.	Innovation in planning and operating the national electricity transmission system; Development of relationship with other Transmission Owners
Changes to operating policy	National Grid can refine its approach to determining operational requirements (such as reserve holding) by changing its modelling approach or in light of experience	Development of operating policy
Changes to industry codes	National Grid can propose changes to industry codes where it believes such change would better facilitate their aims.	Increased co-ordination and efficiency between code parties
Information provision	National Grid can work with the industry to identify information that could be made available to participants which might deliver more effective market information.	More effective functioning of market with regard to system operator actions

Table 4: Generic assessment criteria for National Grid's ability to control inputs

66. The extent to which National Grid can use the tools available to influence the input is considered and given a rating, as follows:
- **None:** National Grid has no ability to use the tool to influence the input
 - **Low:** National Grid's ability to use the tool to influence the input is restricted in timeframe and scope
 - **Medium:** National Grid's ability to use the tool to influence the input is good in some areas (e.g. required volume) but limited in others (e.g. small pool of available service providers impacting price)
 - **High:** National Grid's ability to use the tool to influence the input is good in most areas (e.g. required volume and range of available service providers)

2.3.3 Approach to assessment

67. The assessment of BSIS drivers against National Grid's ability to control and forecast those drivers, as outlined above, is structured in the following way:
- Generation availability (whether generation is not on outage, and can be included in a 'fundamentals' model to determine how it would run in a particular period);
 - Generation running (how available generation would run in light of market fundamentals);
 - Demand level (factors which feed into the overall demand);
 - Demand volatility (factors which drive rapid changes in the demand profile);
 - Transmission availability (the extent to which transmission equipment is available to transport power – i.e. not on outage); and

Section 2

The New Approach to Incentivisation

- Transmission capability (the physical capability of available transmission equipment to transport power).
68. These six categories have been chosen to provide a framework within which drivers of BSIS costs can be considered based on their overall effect, rather than considering individual BSIS cost components; the aim being to minimise duplication where cost drivers influence multiple BSIS components.
 69. The six categories allow for an assessment of the drivers behind BSIS model inputs to be undertaken and a conclusion reached regarding how they should be treated. Where an input is recommended for Ex-Ante input to models, it will contribute to the target costs against which National Grid is incentivised. Where an input is recommended for Ex-Post input to models, it will remove the potential for windfall gains/losses associated with the inability to accurately forecast that input.
 70. The assessment is structured such that new drivers behind the six categories can be incorporated and the assessment re-done to determine appropriate treatment of those drivers.
 71. National Grid considers that inputs should only be treated on an Ex-Post basis where the confidence with which it may be forecast is either 'low' or 'none'. Similarly, National Grid does not consider that inputs are suitable for incentivisation where it has no ability to control them.

Question 2: Do you agree with the criteria used by National Grid to assess the extent to which it can forecast or control BSIS drivers? Are there other criteria that you think National Grid should consider?

2.4 Assessment of BSIS model inputs and drivers

This section presents National Grid's conclusions following assessment of its ability to forecast and control the drivers behind BSIS costs. Detailed information supporting the conclusions drawn can be found in Appendix B.

2.4.1 Generation Availability

Overview

72. Generation availability is a key driver for constraint and margin costs.

Section 2 The New Approach to Incentivisation

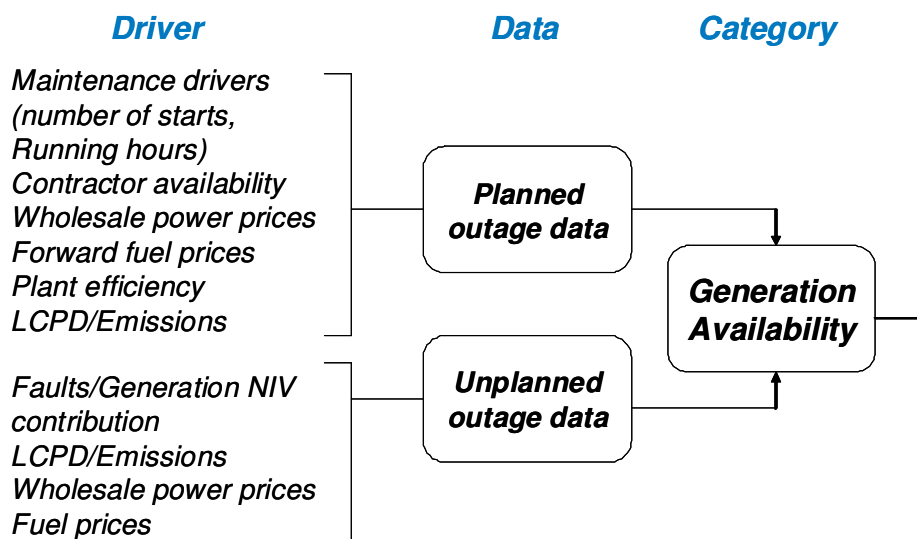

Figure 1: Cost drivers for generation availability

73. Generation availability is a binary input into the 'generation running' model input. If a generator is not on outage, it is available for its running to be modelled in accordance with market fundamentals.
74. Generation availability depends on generation outages (planned and unplanned). Long-term planned outage data is notified to National Grid under the provisions of Grid Code Operating Code 2 (OC2)¹⁰, and is a key input to the process of alignment of generation outages with transmission system outages.
75. An additional factor when considering generator OC2 submissions is the extent to which they interact with demand forecasts and the Short Term Operating Reserve Requirement to give an indication of plant margin, and hence the potential need for National Grid to undertake additional actions to create margin. It should also be noted that the reliability of OC2 data decreases the further ahead of real-time it is for, due to the continual process for optimising outage placement¹¹.
76. Unplanned (fault) outages and delays to generator commissioning schedules have the potential to significantly impact National Grid's performance against agreed scheme targets where they persist for a significant period of time. Unplanned outages will contribute to the Net Imbalance Volume (NIV) to the extent that the generator is unable to adjust its portfolio or procure replacement energy from the market.

National Grid's ability to forecast and control drivers

77. The extent to which National Grid considers the drivers of generation availability can be forecast and controlled; and hence the extent to which it can be incentivised to have an impact on those drivers, is set out in Appendix B, tables 34 and 35.
78. Generator availability tends to be driven by the need to take, and logistics surrounding, maintenance outages. Additionally, long-term adverse movements spark/dark spreads¹² can influence generators' decisions to mothball or regime the running of certain power stations.

¹⁰ National grid is currently considering ways in which the provisions of OC2 might be developed to enhance the outage planning process. Further information can be found in section 5.1.3.

¹¹ This will have implications for the transition to an incentive scheme duration of longer than two years, and is considered further in section 3.2.

¹² The spark spread (dark spread) is the theoretical gross margin of a gas-fired (coal fired) power plant from selling a unit of electricity, having bought the fuel required to produce this unit of electricity. All other costs (operation and maintenance, capital and other financial costs) must be covered from the spark (dark) spread.

Section 2

The New Approach to Incentivisation

79. In the first instance, the processes set out under OC2 should facilitate the efficient co-ordination of outages between generation outages and outages on the National Electricity Transmission System. However there remains the potential for either generation outages or transmission outages to move (for example due to unavailability of contractors or for economic reasons), which creates the possibility of outage misalignment and the potential for constraints to arise.
80. There is also the possibility that fault outages can influence other system operation costs, for example:
 - benefiting export constraints/exacerbating import constraints; and
 - lessening the requirement to take 'footroom' actions (for example where a baseload nuclear generator suffers a persistent fault).
81. It should be noted that the impact of such faults depends on the generator's position in the merit order and the duration of the persistent fault.

Conclusions for Generation Availability

82. In the context of determining generator availability, it is the extent to which drivers behind OC2 and MEL data can be influenced by National Grid that is important, as this determines whether or not they are suitable for incentivisation. If they are, they will be treated on an Ex-Ante basis, whereas if they aren't, they will be treated on an Ex-Post basis.

OC2 data:

83. National Grid uses generator OC2 data within its outage planning processes and has a reasonable confidence in the accuracy of that data in the near-term. National Grid can use mechanisms such as Balancing Services contracts to try to influence the timing of planned generation outages, for example by making a payment to cover costs incurred through movement of outage dates (for example contractor costs or 'lost opportunity' costs). Any subsequent changes to outage dates should then be reflected in revised OC2 submissions. Hence National Grid can be incentivised to have an impact on planned outages and considers it appropriate that the OC2 data that describes them forms an Ex-Ante input to BSIS models. However, it should also be noted that the reliability of OC2 data decreases the further ahead of real-time it is for, as the drivers behind the timing of such outages become more fluid. The impact of this on the proposed approach to incentivisation is discussed further in section 3.2.

MEL data:

84. National Grid is unable to forecast when short-term generation faults will occur (and hence their impact on a party's imbalance position, which contributes to NIV). However, they have the potential to impact National Grid's scheme performance, so they are an important consideration from a BSIS modelling perspective. Whilst such faults will be modelled Ex-Ante using stochastic techniques, National Grid considers that there are situations which may cause significant impact on scheme performance, such as:
 - Where short-term faults persist and have a material impact on a transmission constraint (for example exacerbating an import constraint or ameliorating an export constraint); and
 - Where they remove the need to take actions to manage footroom or have an impact on the need to reschedule generation to increase high frequency response holding.
85. National Grid considers that the issues outlined above give rise to the potential for windfall profit or loss, if such unplanned availability is not appropriately represented when modelled costs are determined. Accordingly, it is proposed that unplanned generator outages should be treated on an Ex-Post basis boarding BSIS models

Question 3: What are your views on National Grid's conclusions regarding the treatment of Generation Availability in BSIS models?

Section 2 The New Approach to Incentivisation

2.4.2 Generation Running

Overview

86. Generation running is a key driver for constraint and margin costs. It is a modelled parameter that forms an input into other BSIS models, such as constraints and margin.

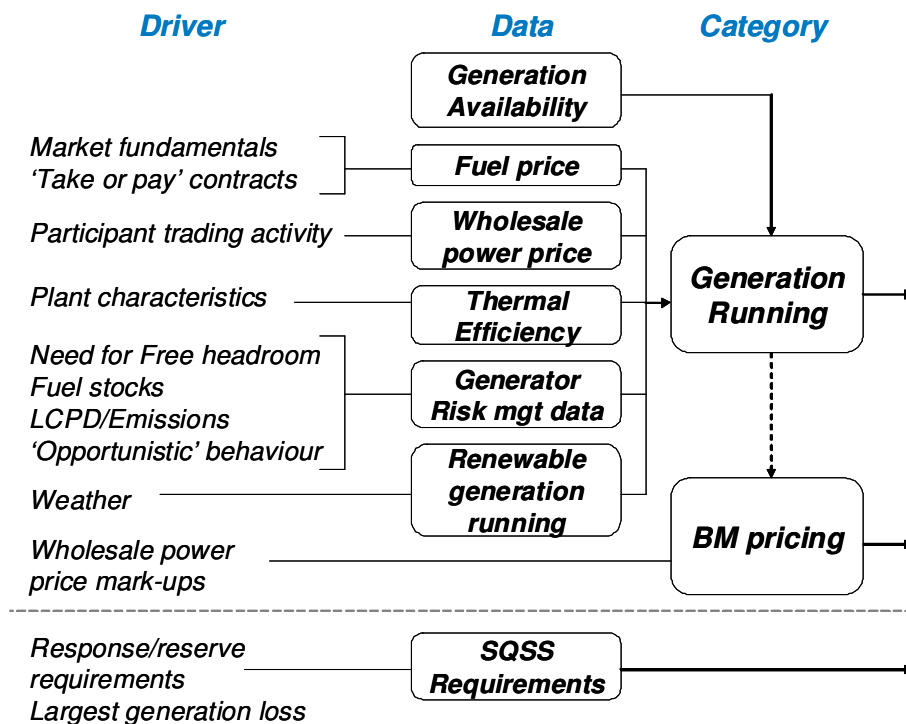

Figure 2: Cost drivers for Generation Running

87. For a generator to be able to run, it needs to not be on outage. For available generation, whether or not it will run depends primarily on the interaction between fuel prices, wholesale power prices and generator efficiency factors. However, there are additional considerations, such as generators' approach to portfolio risk management (which, for example, will influence the amount of 'free headroom' available on their plant); and from a wider system operator perspective (shown in parallel to the 'generation running' drivers above), the need to consider the requirements of the Security and Quality of Supply Standards.
88. Generation running is notified to National Grid via physical notification submissions through the timescales, becoming fixed at gate-closure (one and a half hours ahead of real-time). Generators submit prices at which National Grid may instruct them to deviate from physical notification levels – these tend to be at a 'mark-up' from general wholesale price levels.

National Grid's ability to forecast and control drivers

89. The extent to which National Grid considers the drivers of generation running can be forecast and controlled; and hence the extent to which it can be incentivised to have an impact on those drivers, is set out in Appendix B, tables 36 and 37.
90. Whether or not a generator will be running depends primarily on the differential between its fuel prices and the wholesale power price, taking into account the efficiency of the generator. National Grid has a number of tools at its disposal which it can try to use to manage generation running. The price National Grid pays for the various tools

Section 2

The New Approach to Incentivisation

will generally be based on a view of what would be paid for alternatives (e.g. whether to enter into a contract or use the BM). Hence from an incentive viewpoint it is important that a 'fundamentals' model for determining generation running paints a reasonable picture of what will actually happen, as this forms the basis upon which National Grid's use of the various tools is incentivised.

Conclusions for Generation Running

91. In the context of determining generator running, the drivers behind generator running are direct inputs to BSIS models; hence it is necessary to consider whether or not they are explicitly treated on an Ex-Ante or Ex-Post basis:

Generation Availability:

92. For the reasons set out in section 2.4.1, Generation Availability data, with the exception of faults on nuclear power stations should be an Ex-Ante input to the Generation Running model.

Fuel Price, Wholesale Power Price:

93. Whilst data for fuel prices and wholesale power prices are available, their associated volatility and National Grid's inability to influence them suggests that Ex-Post treatment in BSIS models is appropriate.

Generator Efficiency Factors:

94. Once known, generator efficiency factors vary little. Hence they should be treated as an Ex-Ante input.

Generator Risk Management Data:

95. Generator risk management data feeds into BSIS models primarily in the form of 'free headroom', although other elements, such as the need to manage fuel stocks, can be an influence on balancing services contracts. The inability to derive suitable data relating to how generator risk management activities manifest themselves, in the form of 'free headroom' presented to National Grid at gate closure, suggests that it should be fed into BSIS models as an Ex-Post input.

Renewable Generation Running:

96. The volatility associated with wind generation in particular, the difficulty in forecasting wind speed accurately as lead-time increases and the ability of wind generation to have a significant impact on SO costs such as constraints, suggests that it should form an Ex-Post input to BSIS models.

Frequency Response/Reserve Requirements/Largest generation loss:

97. Frequency response/reserve requirements and the largest generation loss are known and vary little. Hence they should be treated as an Ex-Ante input.

BM Pricing:

98. Bid-offer prices are a key driver behind the costs National Grid faces and its contracting and risk management strategies focus on trying to deliver value against expectations of submitted bid-offer price levels. Hence National Grid should be incentivised to deliver value in this area and wholesale power price mark-ups should be treated as an Ex-Ante input.

Question 4: What are your views on National Grid's conclusions regarding the treatment of Generation Running in BSIS models?

Section 2

The New Approach to Incentivisation

2.4.3 Demand Level

Overview

99. The level of demand on the transmission system is a key driver for frequency response, footroom and constraint costs, and is a direct input to BSIS models.

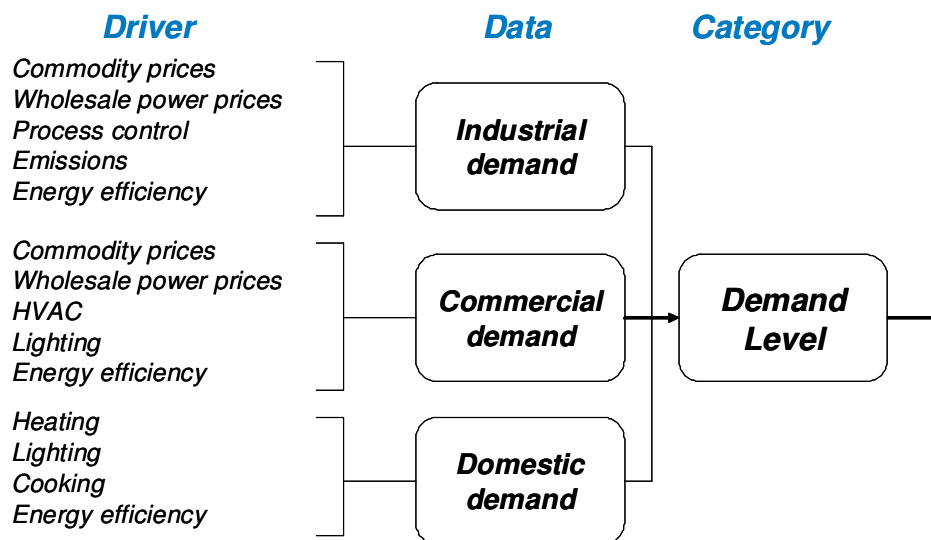

Figure 3: Cost drivers for Demand Level

100. The demand level depends on a range of factors linked to the behaviour of industrial, commercial and domestic consumers. Whilst in the context of current BSIS the demand level is generally accepted as an Ex-Ante forecast input, there are few things that National Grid can do to influence the demand level. The need for the SO to be able to influence demand is likely to become increasingly important into the future, for example as the need to charge electric vehicles increases and following the introduction of smart meters.

National Grid's ability to forecast drivers

101. National Grid's ability to forecast demand is well established, and it is appropriate to treat demand as an Ex-Ante input to BSIS models.
102. Currently, National Grid seeks to identify suitable industrial, commercial and domestic load types that can provide demand deferral services to assist with provision of frequency response/reserve services. In the future, changes in the volume and type of demand, for example through increased penetration of electric vehicle use or the introduction of smart meters, might have a short-term impact on National Grid's ability to forecast demand whilst new behaviours are understood. However they may also provide additional scope for system operator service provision.

2.4.4 Demand Volatility

Overview

103. The level of demand volatility on the transmission system is a key driver for frequency response, footroom and constraint costs.

Section 2 The New Approach to Incentivisation

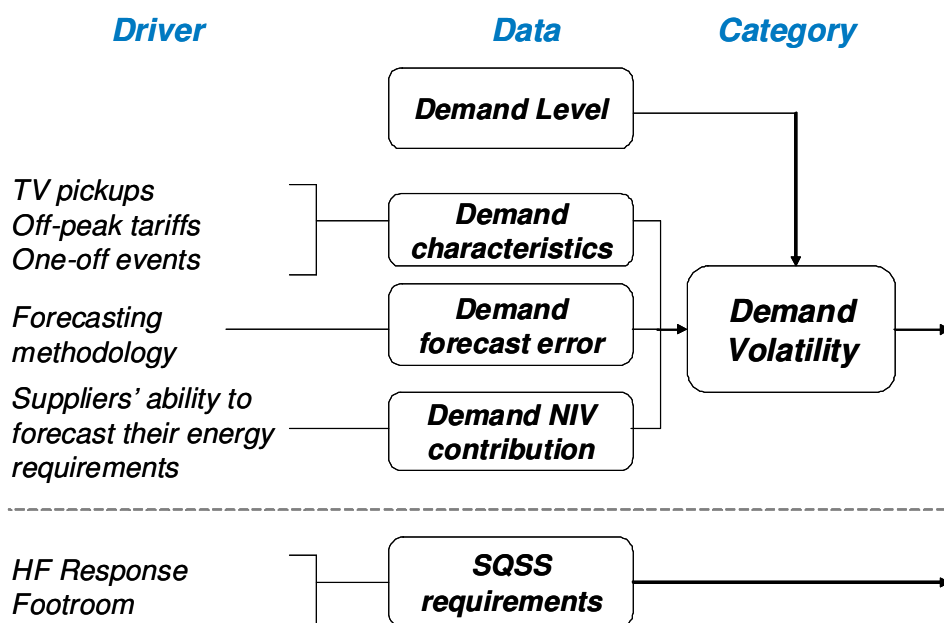

Figure 4: Cost drivers for Demand Volatility

104. Demand volatility depends on a range of factors linked to the behaviour of industrial, commercial and domestic consumers. Rapid demand changes, such as those caused by TV pickups and the incidence of off-peak heating tariffs, are of particular interest when considering the effective management of the demand profile.
105. The accuracy of individual supplier's estimates of their energy requirements, and their appetite for risk, will dictate their contracting strategy and, to the extent that they are over- or under-contracted, drive the demand NIV contribution.

National Grid's ability to forecast and control drivers

106. The extent to which National Grid considers the drivers of demand volatility can be forecast and controlled; and hence the extent to which it can be incentivised to have an impact on those drivers, is set out in Appendix B, tables 38 and 39.
107. National Grid forecasts demand using established techniques and a wealth of historic data; and has a number of mechanisms which it can try to use to respond to rapid changes in demand. Most are enacted close to real time, although there exists the possibility to re-schedule or defer demand ahead of time.

Conclusions for Demand Volatility

108. In the context of determining demand volatility, the drivers behind demand characteristics, demand forecast error and SQSS requirements are direct inputs into BSIS models.
109. As National Grid has a high degree of control over the drivers behind those inputs, due to its demand forecasting ability and Balancing Services contracting capability, it is clear that the management of demand volatility should be incentivised; and associated data required by BSIS models should be treated on an Ex-Ante basis.
110. However, as National Grid is unable to forecast or influence the demand contribution to NIV, National Grid considers (as with generation contribution to NIV) that it be treated on an Ex-Post basis when determining the NIV to be used in models.

Section 2

The New Approach to Incentivisation

Question 5: What are your views on National Grid's conclusions regarding the treatment of Demand Volatility in BSIS models?

2.4.5 Transmission Availability

Overview

111. Transmission availability is a key driver for constraint costs and is a direct input to the power system studies that feed into BSIS models.

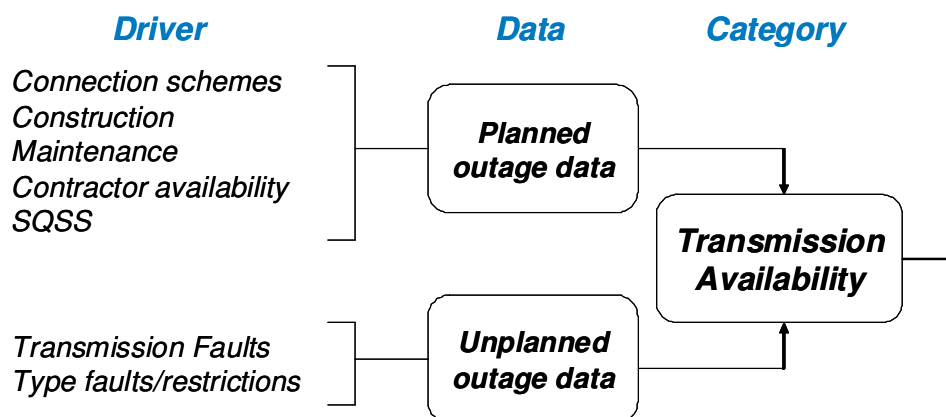

Figure 5: Cost drivers for Transmission Availability

112. Transmission availability is a function of the number of outages required to be taken on transmission equipment, and is linked to construction (new generation and load) and maintenance (non-load) activities.

National Grid's ability to forecast and control drivers

113. The extent to which National Grid considers the drivers of transmission availability can be forecast and controlled; and hence the extent to which it can be incentivised to have an impact on those drivers, is set out in Appendix B, tables 40 and 41.

114. National Grid builds outage plans based on information from its own transmission owner function and the other transmission owners under the provisions of OC2 and the System Operator – Transmission Owner (SO-TO) Code. The processes set out in OC2 are dynamic in nature and allow for outages to be changed and notified accordingly, which means that taking a view ahead of time is always going to be subject to an element of risk.

115. The system operator has to balance the release of transmission equipment for outage with the need to maintain pre- and post-fault system security in accordance with standards prescribed in the SQSS.

Conclusions for transmission availability

116. In the context of determining transmission availability, the drivers behind planned and unplanned outages are direct inputs into BSIS models. Hence it is necessary to consider whether or not they are explicitly treated on an Ex-Ante or Ex-Post basis:

Section 2

The New Approach to Incentivisation

Connection scheme outages, Construction/maintenance outages and Contractor Availability:

117. National Grid has a high degree of control over the outage planning processes and should be incentivised to deliver efficiencies in the planning and execution of outages.
118. National Grid has a reasonable degree of control over the planning of contractor availability for its own outages. Whilst it has little control over the availability of contractors for other TOs' outages it should be incentivised to deliver efficiencies in the overall planning and execution of transmission system outages. Hence National Grid can be incentivised to have an impact on it and considers it appropriate that OC2 data forms an Ex-Ante input to BSIS models. However, as with generation outage data, it should also be noted that the reliability of OC2 data decreases the further ahead of real-time it is for – this is discussed further in section 3.2.

SQSS:

119. Transmission planning/operational requirements as specified in the SQSS are known and vary little. Hence factors such as the largest credible generation loss to be catered for should be treated as an Ex-Ante input. It should be noted however that there exists the potential for an SQSS change to introduce a material change in the way the system is operated, which could bring with it a step-change in SO costs unforeseen at the time an incentive is set. Under such circumstances it may be appropriate to consider a mechanism to allow the parameters of such scheme to be revisited.

Transmission equipment faults and Type faults/restrictions:

120. Whilst National Grid is unable to forecast the incidence of transmission faults, it is incentivised to minimise the likelihood and impact of such faults under its Transmission Network Reliability Incentive. Hence it would not be appropriate to afford them Ex-Post treatment under BSIS.

Question 6: What are your views on National Grid's conclusions regarding the treatment of Transmission Availability in BSIS models?

2.4.6 Transmission Capability

Overview

121. Transmission capability is a key driver for constraint costs and is a direct input to the power system studies that feed into BSIS models.

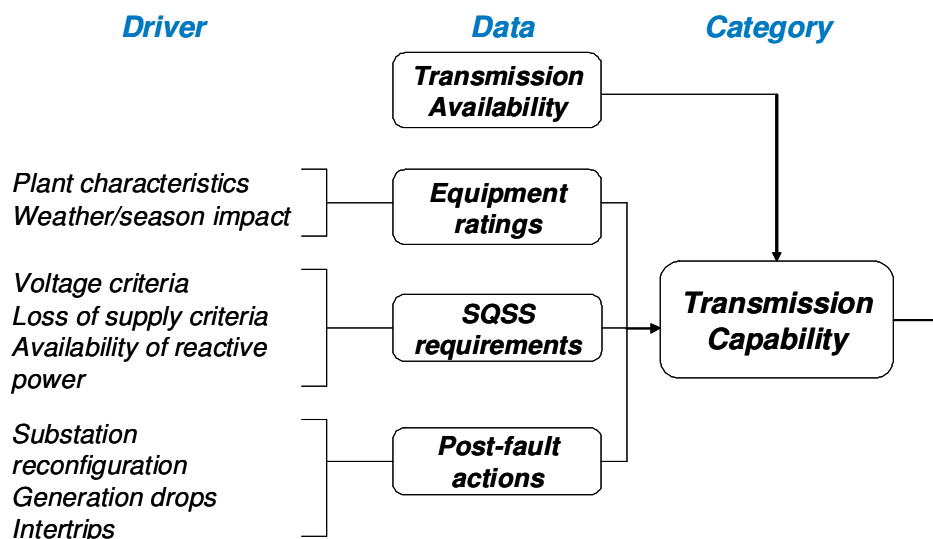

Figure 6: Cost drivers for Transmission Capability

122. Transmission capacity is a function of the initially identified requirement for capacity when the transmission equipment was installed and the ability of that equipment to be able to cope with short-term overloads (for example following faults on other transmission equipment).

National Grid’s ability to forecast and control drivers

123. The extent to which National Grid considers the drivers of transmission capability can be forecast and controlled; and hence the extent to which it can be incentivised to have an impact on those drivers, is set out in Appendix B, tables 42 and 43.

124. Operation of the transmission system is one of National Grid’s key roles and it has a range of tools available to assist it in the management of transmission capability.

Conclusions for transmission capability

125. In the context of determining transmission capability, the drivers behind equipment ratings, SQSS requirements and Post-fault actions are direct inputs into BSIS models.

126. However, as National Grid has a high degree of control over the drivers behind those inputs, either because it owns the equipment, has the ability to use SO tools to manage them or can influence them using policy/code routes, it is clear that the maximisation of transmission capability should be incentivised. Where associated data is required by BSIS models, it should be treated on an Ex-Ante basis.

Question 7: What are your views on National Grid’s conclusions regarding the treatment of Transmission Capability in BSIS models?

Section 2

The New Approach to Incentivisation

Treatment of the retail price index (RPI)

127. A range of inputs to BSIS models are specifically impacted by changes in the RPI, for example:
- Reactive power default payment arrangements
 - Black start
 - Operational intertrips
 - Other multi-year balancing services contracts
128. The prices associated with these services are based on a range of factors and RPI. National Grid should be incentivised to develop and procure services that deliver value against what currently exists; hence their expected cost should be considered as an Ex-Ante input to models. However National Grid notes that RPI is beyond its sphere of influence and difficult to accurately forecast; and so should be treated as an Ex-Post input to BSIS models.

Section 2

The New Approach to Incentivisation

2.4.7 Summary of treatment of inputs

129. Table 5 summarises the conclusions drawn in section 1.

Generation:	Forecast Confidence:	Treatment in models:	Degree of Control:	Suitable for incentivisation?
Long Term Generation Availability (OC2)	Low - medium	Ex-Ante	Low - medium	Yes
Short Term Generation Availability (MEL)	None	Ex-Post	None	No
Generation Contribution to NIV	Low	Ex-Post	None	No
Generator Fuel Prices	Low	Ex-Post	None	No
Wholesale Power Prices	Low	Ex-Post	None	No
Generator Efficiency Factors	Medium	Ex-Ante	None	No
Free headroom	Low	Ex-Post	None	No
Renewable generation running	Low	Ex-Post	None	No
Frequency response/reserve requirements	High	Ex-Ante	Low	Yes
Largest generation loss	High	Ex-Ante	Low	Yes
BM Pricing/wholesale power price mark-ups	Low - medium	Ex-Ante	Low	Yes
Demand:				
Demand Level	High	Ex-Ante	None - Low	Yes
Demand volatility	Medium	Ex-Ante	Low - medium	Yes
Demand contribution to NIV	Low	Ex-Post	None	No
Largest demand loss	High	Ex-Ante	Low	Yes
Transmission:				
Transmission availability (OC2)	Medium	Ex-Ante	Medium	Yes
Transmission capability	Medium - high	Ex-Ante	Medium	Yes
Other:				
RPI	Low	Ex-Post	None	No

Table 5: Summary of proposed treatment of cost drivers.

3. Modelling

3.1 Energy Model Development

3.1.1 Introduction

130. During Phase 2 of the SO Incentive Review National Grid reviewed the approach to BSIS cost forecast modelling and the Energy and Constraint models themselves in light of Ofgem's Phase 1 conclusions. As set out in Section 1 above, the methodology proposed by Ofgem and adopted by National Grid involves the agreement of the models and some model inputs ex-ante i.e. prior to scheme start. Other inputs, which are not within National Grid's control as System Operator or are unpredictable, are to be input ex-post to the models using actual data.
131. Having re-assessed the various relationships represented by the models and determined the criteria by which to assess whether inputs should be ex-ante or ex-post, the models have been developed to facilitate and incorporate both types of datasets. This was achieved by, for example, examining and modelling the statistical relationships between these variables so that these relationships form part of the models themselves. The result of this is that ex-post data can be fed into the pre-determined (and agreed) model in combination with ex-ante datasets.
132. During this model review period, National Grid focused on developing and extending the existing BSIS cost forecasting models in order that they be applicable to, and representative of, a 24 month period; facilitated the introduction of ex-post variables; and undertook investigations on improving the modelling of cost drivers that have shown, as indicated by previous analysis undertaken, to have a noticeable impact on modelled costs. Consistent with the recommendations from Phase 1 of the SO review, the analysis has been focused on the following actions:
 - Improvements to the Energy Imbalance forecast model, in particular in the relationship between wholesale power price and prices in the Balancing Mechanism
 - Improvements to the Margin volume forecast model
 - Investigation of a new Margin price forecast model
 - Simplification of the following forecast models:
 - Frequency Response
 - Fast Reserve
 - Footroom
133. Following recommendations from Phase 1 of the SO Review, National Grid undertook a procurement exercise for a constraint cost forecasting model. As a result of this competitive tender process Plexos, an 'off-the-shelf' model developed by Energy Exemplar, was selected as the candidate that best met the immediate and longer term requirements for constraint cost forecasting.
134. This section therefore sets out each model within the Energy model, and the [expected inputs to and operation of the] Constraints model, used to forecast the various elements of BSIS costs, given the treatment of model inputs as set out in Section 1. In most instances, regression analysis has been used in order to represent the variables and model the relationships between BSIS cost drivers and the costs themselves.
135. Regression Analysis is used to determine the type and strength of relationship between two or more variables. This type of analysis has been employed to model BSIS forecast costs because it facilitates an understanding of how a dependent variable changes when independent variables are altered (e.g. the extent to which BM Prices are affected by wholesale power price). The impact of introducing different variables may also be assessed using regression analysis in order to determine which bears the greatest relation to the dependent variable (or BSIS cost) in question.

136. Once a regression model has been constructed in this way, it is important to confirm how well it represents the data used which is also known as the level of fitness. Appropriate statistical methods have therefore been employed to undertake this test of fitness where the closer the resultant number is to 1, the better the level of fitness. More information on the techniques employed can be found in Appendix A.
137. The result of this process is therefore that each model consists of a number of variables (which produce the best level of fit) and each variable has a coefficient in the regression which ultimately defines the regression equation.
138. Having established and statistically tested a model in this way, historical outturn data is then used along with modelled data to show that the model reflects, as closely as possible, the real cost of system operation. This process is called 'back testing'.
139. Historically these cost forecasting models have been used to derive BSIS forecast costs which are then agreed with Ofgem as part of a total scheme forecast cost target. The revised ex-post/ex-ante methodology, however, means that the relationships between the chosen variables within the models (regressions) will actually form part of the agreed scheme (ex-ante). Thus, each model will include an ex-ante defined relationship - these defined relationships will be used throughout the duration of the scheme to calculate an ongoing scheme target with use of both ex-ante and ex-post inputs.
140. Each model within the Energy Model will therefore (typically¹³) comprise:
 - An ex-ante defined relationship between a number of variables
 - A number of ex-ante inputs
 - A number of ex-post inputs
141. This section will therefore detail what the model regressions are and the variables to be used within each regression. In order to illustrate the robustness of the analysis and to demonstrate accuracy of modelled costs versus actual costs, the back testing of these models is presented in Appendix A. The coefficients for all model regression variables are also set out in Appendix A.
142. Although each model typically comprises of some regression analysis, not every model will use both ex-ante and ex-post inputs. Therefore, where applicable, the ex-ante inputs to, and source of ex-post datasets for, these models are also set out within this section as these will similarly be agreed prior to scheme commencement.
143. Finally, given the ex-ante/ ex-post approach to modelling the various BSIS cost elements, the specific areas upon which National Grid is incentivised to achieve cost efficiencies are highlighted following the explanation of each model.

3.1.2 Energy Imbalance

144. The volume of energy imbalance actions is also known as Net Imbalance Volume (NIV) and is often referred to as market length. The price of energy imbalance actions is largely dependant on the submitted (and accepted) prices in the BM (due to the large number of actions taken in the BM) and pre-gate closure energy trades, which hold a relationship with the prevailing wholesale power price.
145. Previously, the Energy Imbalance model used a forecast level of wholesale power price (herein referred to as Single Price Net Imbalance Reference Price or SPNIRP), in accordance with possible Net Imbalance Volume (NIV) outcomes and estimated BM prices, to determine the cost of resolving the NIV i.e. Energy Imbalance cost.
146. In order to forecast BM prices relative to the level of SPNIRP, the model used to assume mark-ups or mark-downs to SPNIRP according to whether the market was long (negative NIV) or short (positive NIV). Two multipliers were applied to SPNIRP to determine the BM price: a multiplier of 0.8 being applied in a long market and a multiplier of 1.4 being applied in

¹³ Some models will not include both ex-ante and ex-post inputs (e.g. the Energy Imbalance model does not consist of any ex-ante inputs) however all models will include an ex-ante relationship

Section 3 Modelling

a short market. Those multipliers had been determined on the basis of a long-term average, as illustrated in Figure 7 below.

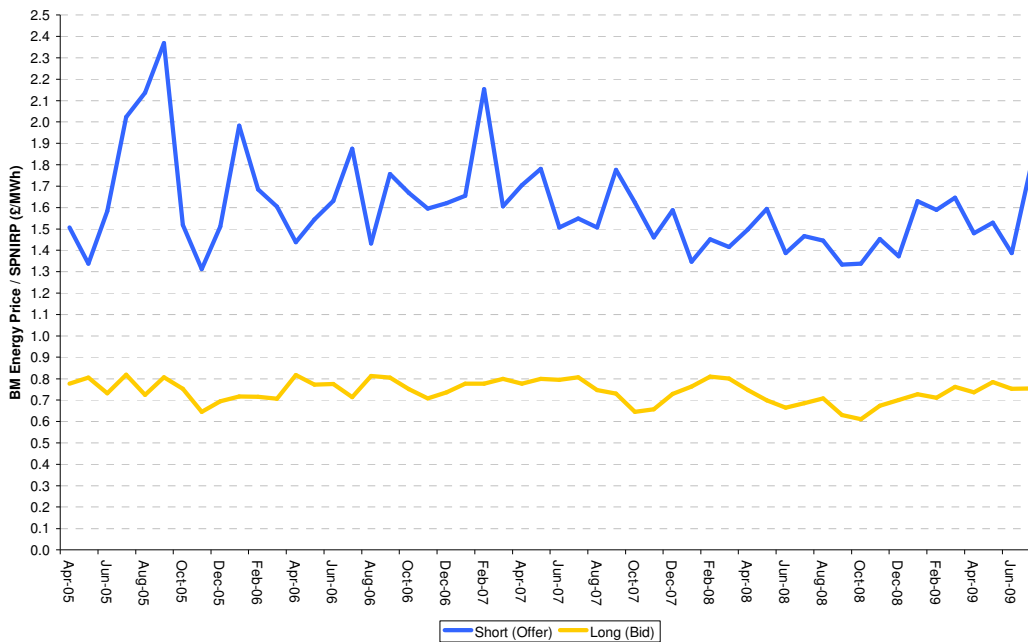

Figure 7: BM Prices to SPNIRP Ratios

Energy Imbalance Model Overview

147. Following the review of cost drivers described in Section 1, two inputs to the Energy Imbalance model, namely Net Imbalance Volume (NIV) and wholesale power price (SPNIRP) are to be input ex-post to the model using outturn data. This eliminates the requirement for the model to estimate, firstly, possible NIV outcomes and, secondly, SPNIRP values for those NIV outcomes.
148. The revised Energy Imbalance model, to be discussed in the following section, is demonstrated by the diagram in Figure 8 below:

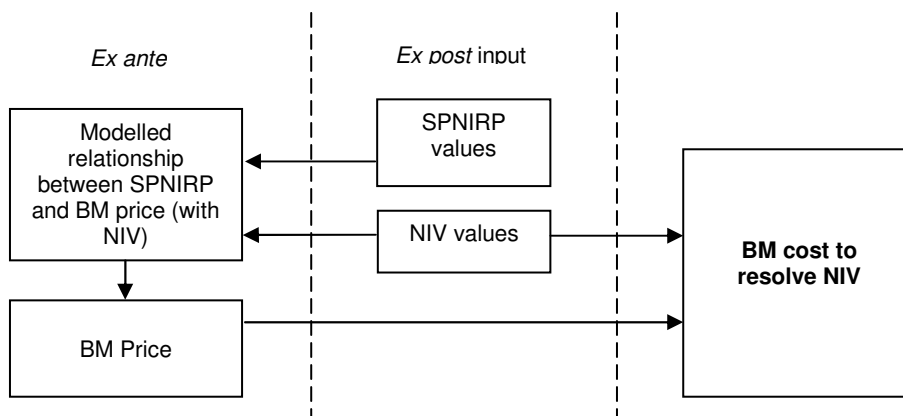

Figure 8: The Energy Imbalance cost forecast model

Energy Imbalance Model Parameters

149. The relationship between the variables SPNIRP and BM Price was firstly reviewed to provide a more accurate methodology for forecasting BM prices given the level of SPNIRP. The new proposed model is based on a non-linear regression of observed BM Prices given SPNIRP and NIV.

Section 3 Modelling

150. In order to arrive at this result, an initial regression analysis, using 5 year historical SPNIRP and BM Price data, was carried out using two types of regression curves, namely *Log* and *Log + Linear*, as shown in Figure 9. Figure 9 shows that the *Log + Linear* regression curve on the right-hand side (i.e. a straighter curve) better fits the modelled data.

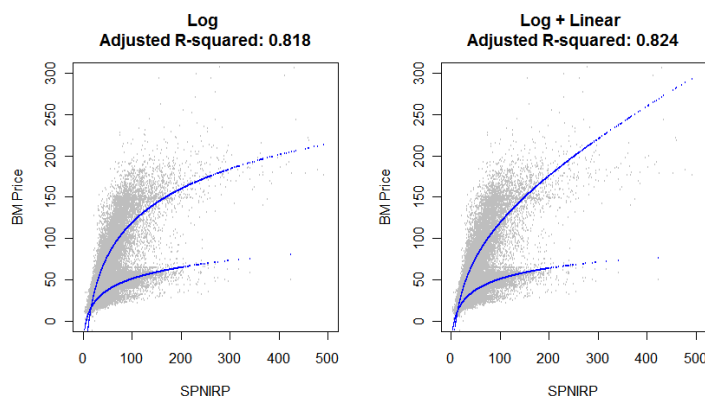

Figure 9: Initial regression analysis using Log (left) and Log + Linear (right) regression curves

151. Having modelled the relationship between SPNIRP and BM Price, NIV was then introduced to the regression as a further variable. NIV was expected to further explain the relationship between SPNIRP and BM Price because as the market becomes increasingly short, there is lower availability of generation in order to meet demand and therefore BM prices will be higher. Further analysis was therefore carried out by taking into account the historical value of NIV (illustrated in Figure 10). Figure 10 shows that the *Log + Linear* regression curve (i.e. a straighter curve), with the value of NIV taken into account, gives the best level of fit to the modelled data.

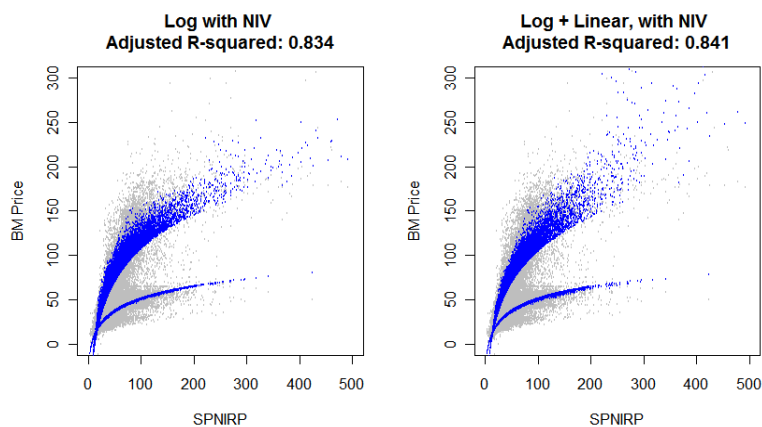

Figure 10: Non-linear regression analysis, with NIV as extra variable

152. The variable coefficients and back testing for this regression can be found in Appendix A.

Energy Imbalance Ex-ante Inputs

153. There are no direct ex-ante inputs to the Energy Imbalance model, however, the SPNIRP/ BM Price relationship (with NIV) will need to be agreed prior to the start of the scheme and is therefore considered ex-ante.

Energy Imbalance Ex-post Inputs

154. The ex-post inputs to the Energy Imbalance model are SPNIRP and NIV values:
- NIV values are to be obtained from the National Grid Economic Data warehouse (NED), a system that stores and aggregates operational and half-hourly Settlement Data.
 - SPNIRP is the single price net imbalance volume reference price for each settlement period and is calculated in accordance with the Transmission Licence¹⁴

Energy Imbalance Model Summary

155. The combined effect of the developments made to the Energy Imbalance model, as described above, are that the model has been simplified to a function of a BM price/ SPNIRP (with NIV) relationship which is determined ex-ante, and two ex-post inputs (NIV and SPNIRP). The revised model can be demonstrated via the following formula:

$$\text{Energy Imbalance cost scheme target} = \text{NIV (ex post)} \times \text{BM Price (ex ante regression using ex post SPNIRP and NIV)}$$

Energy Imbalance Incentive

156. The above proposed model means that the incentive on National Grid with regard to Energy Imbalance lies in trying to improve the efficiency of the prices accepted in the Balancing Mechanism i.e. trying to match or beat the historic BM price premium over wholesale power prices.

Question 8: To what extent do you think that National Grid's proposed approach to delivering a modelled target cost for Energy Imbalance will act as an appropriate incentive to deliver cost efficiencies?

3.1.3 Margin

157. Margin costs are incurred when National Grid synchronises additional units onto the system in order to ensure that the Short Term Operating Reserve Requirement (STORR) is met. The STORR is set such that there is a risk of only 1 in 365 days that total demand will not be able to be met. Setting the STORR is a careful balance:
- A reduction in the requirement implies less expensive system operation;
 - Achieving cost reduction through the reduction of this requirement, without detailed understanding through improved modelling, implies an acceptance of higher risk of demand disconnection.
158. The margin model is separated into volume, price and total cost elements.. These three elements (the margin volume model, the margin price model and the resultant margin cost model) are detailed in turn in the following sections.
159. Margin has been modelled on the basis of the following equation/ variables (please refer to the Margin model section within Appendix A for further explanation as to why these variables form the basis of the model):

$$\text{Margin} = \text{STORR} + \text{NIV} - \text{Headroom}$$

160. Headroom created by reduced output from self-despatched generation units, coupled with a longer market, reduces the need of the system operator to create margin by taking actions (and therefore the cost associated with those actions). Such actions, for example, would be to reduce the output on a generating unit from its maximum export level and synchronising a

¹⁴ The SPNIRP calculation can be found in Schedule A to Special Condition AA, part B paragraph B4 of the National Grid Electricity Transmission Licence.

generation unit to maintain energy balance. For this reason, headroom is also known as ‘free reserve’.

Margin Volume

Margin Volume Model Overview

161. In previous years the margin volume model firstly estimated the level of free headroom on the system given the length of the market (NIV) at particular times of the day/ year. However, as set out in Section 1, both NIV and headroom are to be input ex-post to the models which eliminates the requirement for the margin volume model to estimate these values. Instead, an ex-ante margin volume/ NIV/ headroom relationship uses ex-post headroom and NIV values to determine a margin volume forecast.
162. The Margin Volume model also includes additional ex-ante elements which are as follows:
- A reserve volume for wind uncertainty;
 - A forecast contracted STOR volume;
 - A static frequency response/ Firm Frequency Response (FFR) volume¹⁵; and
 - A Constrained Margin Management volume
163. The revised Margin Volume model, to be discussed in more detail in the following section, is demonstrated by the diagram in Figure 11 below which shows which elements and inputs are to be ex-ante and which inputs are to be ex-post.

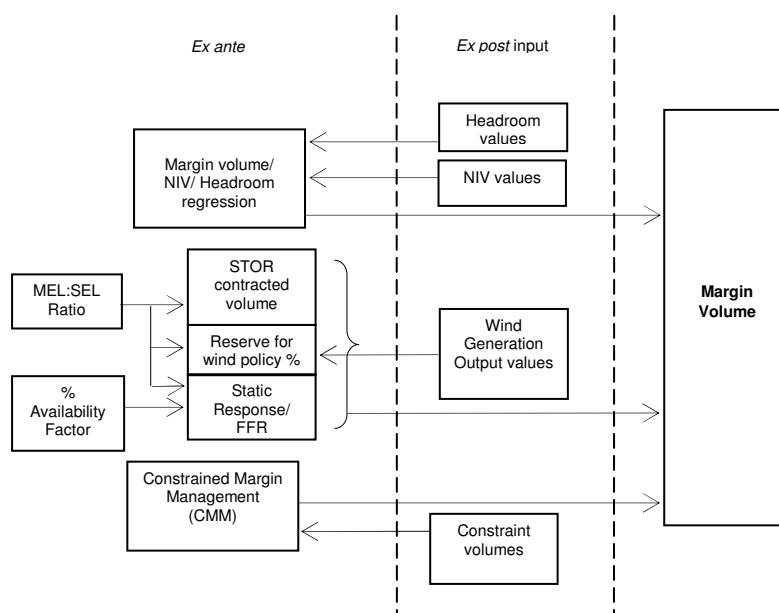

Figure 11: The Margin Volume Model

Margin Volume Model Parameters

164. On the basis of the rationale above, the first element of the margin volume model consists of an ex-ante regression with margin volume, NIV and headroom variables depending on

¹⁵ This volume captures all frequency response provision other than that provided by the mandatory frequency response market.

season (Summer/ Winter) and time of the day (Peak/ Extended Peaks). The output of this regression is a half-hourly forecast of margin volume which is subsequently aggregated to give a monthly forecast volume. There is an additional level of sophistication in this model whereby the calculation takes into account that no negative values can exist in the model because, by definition, margin actions must be positive. This is achieved using a censored regression¹⁶.

165. Although this margin volume/NIV/headroom relationship is an ex-ante element of the model, headroom and NIV values are to be input ex-post to the model using actual data. The model variables, with their coefficients, are set out in Appendix A..
166. Back testing has been performed to compare the actual and modelled values of margin volume using the above regression. The results can be found in Appendix A.

Short Term Operating Reserve Requirement (STORR)

167. As set out above, margin volume is also modelled using the STORR. The STORR level comprises a number of elements which have an effect on the volume of margin actions required and therefore the total cost of margin. These elements are:
 - Wind generation output
 - Contracted Short Term Operating Reserve (STOR)
 - Availability of static frequency response/ FFR providers
168. An alternative treatment is being proposed in the margin model for these parameters rather than regression analysis. The reasons for alternative treatment, along with the proposed methodology for how the margin volume model will incorporate these elements, are as follows:

Wind Generation Output

169. The total reserve requirement level is set, in part, by the size of the largest forecast errors. Currently those largest errors are driven by demand forecast and generation loss as wind capacity on the system is relatively small. As more wind connects to the system the wind capacity will be large enough that the single biggest driver behind the reserve requirement level will be wind capacity. This is discussed in more detail in a paper published by National Grid entitled 'Future Balancing Service Requirements: Reserve'¹⁷.
170. During the incentive period it is anticipated that wind capacity will have increased to such a level that the wind forecast error will also be significant. National Grid has made historic policy decisions (described further below) as to the percentage of forecast wind output required to be held on conventional generating units in the event that forecast wind output is not realised. This policy decision has varied over time as more has been learnt about the effects of wind generation forecasting errors and a greater understanding obtained of the relationship between forecasting error, market length and free headroom.
171. National Grid does not currently consider that this variable is suitable for regression, given the variation in this policy percentage over time.
172. It should be noted at this point that wind generation output is to be considered as an ex-post input to this model (as set out in Section 1). The percentage of forecast wind output to be held as reserve, however, will continue to exist within the model as a variable which will be set ex-ante. Further information on how the reserve for wind requirement is proposed to be set can be found in paragraph 185 below.

STOR and Static Frequency Response

¹⁶ A regression model where the variable of interest is only observable under certain conditions - in this case when it is a positive number.

¹⁷ This document can be found on the National Grid website using the following link:
http://www.nationalgrid.com/NR/rdonlyres/55610D9A-C53A-4E28-88C6-29AE5DF72EF2/42697/Future_Balancing_Services_Requirements_Reserve1.pdf

Section 3 Modelling

173. National Grid currently believe that both historic contracted STOR and static frequency response levels/ FFR provider availability are unsuitable for regression because historical data for these elements present a low variance level on a half hourly basis (or indeed on a monthly basis – as illustrated below in Table 6. This low variance is as a result of contracting strategies and therefore is a factor of the tenders received for these services and the reserve requirement to be contracted ahead of real time. It is however still important that any increases or decreases to these two elements be captured within the Margin Volume model as they offset the STORR.

STOR Contracts		Apr	May	Jun	Jul	Aug	Sep	Oct	Nov	Dec	Jan	Feb	Mar
Financial Year	2005/6	2,098	2,048	2,098	2,258	2,258	2,258	2,178	2,317	2,317	2,023	2,317	2,312
	2006/7	2,611	2,552	2,611	2,683	2,683	2,683	2,631	2,515	2,515	2,539	2,515	2,586
	2007/8	2,364	2,394	2,394	2,394	2,394	2,300	2,342	2,388	2,388	2,388	2,388	2,391
	2008/9	2,305	2,526	2,526	2,526	2,526	2,381	2,362	2,305	2,305	2,305	2,355	2,355
	2009/10	2,597	2,712	2,712	2,712	2,712	2,125	2,333	2,751	2,751	2,751	2,745	2,745

Response Providers		Apr	May	Jun	Jul	Aug	Sep	Oct	Nov	Dec	Jan	Feb	Mar
Financial Year	2005/6	495	630	638	638	638	638	553	673	787	811	811	811
	2006/7	766	761	811	811	811	811	811	811	811	811	811	811
	2007/8	811	811	811	811	811	811	811	641	641	811	811	565
	2008/9	518	518	518	554	415	569	569	463	463	455	703	703
	2009/10	363	703	703	703	803	804	540	540	540	540	567	567

Table 6: STOR and static frequency response contracted volumes 2005-2010

174. Based on the above rationale, wind generation, static frequency response and STOR will be treated within the margin forecast model as follows (this methodology does not differ from the 2010/11 BSIS):
- On a monthly basis, the volume weighted average of each of the above parameters will be calculated. The weighted averages are used to ensure that this baseline level is consistent with the margin volume regression model.
 - The ex-ante forecast level of STOR and static frequency response/ FFR contracts will be compared with their respective historic volume weighted average (or baseline).
 - Average wind for reserve level for the month is calculated in accordance with the policy percentage figures as set out in paragraph 187 below (using ex-post wind generation output values).
 - The forecast (aggregated) monthly margin volume is increased or decreased (adjusted) by the difference between the forecast (or ex-post) data and the volume weighted average (for each element).

Margin Volume Ex-ante Inputs

175. In order to facilitate the above treatment of STOR, static frequency response/ FFR and wind generation within the margin volume model the following ex-ante model inputs are required:
- STOR Contracted Volume Forecast
176. A forecast volume of contracted STOR volume is determined by examining the historical trend of contracted volumes since the commencement of the STOR service in 2007 and projecting this trend forward.
- Stable Export Limit (SEL) to Maximum Export Limit (MEL) Ratio
177. A SEL to MEL ratio is included in the margin model calculations because when National Grid requires a certain level of margin, as described by the total synchronised MEL in the system, it synchronises a machine in the system by only buying the equivalent to its minimum output level (SEL). This relationship is based on the physical characteristics of the generating units connected to the system and, therefore, is not forecast to change over the duration of the incentive scheme. This ratio is calculated as a function of the units that National Grid typically selects for margin.

Section 3 Modelling

178. The graph in Figure 12 below illustrates how this number has changed since BETTA and shows that the number has remained relatively stable. It is proposed that the 12 month volume weighted average of 0.572 be used as an ex-ante input to the margin model (as opposed to 0.619 which was used for the current scheme as indicated by the red line on the graph below). It is likely that this number has been influenced by recently-commissioned CCGT plant – updating the analysis ensures that the most recent trend in system operation decisions and plant mix typically used for margin actions are reflected in the model.

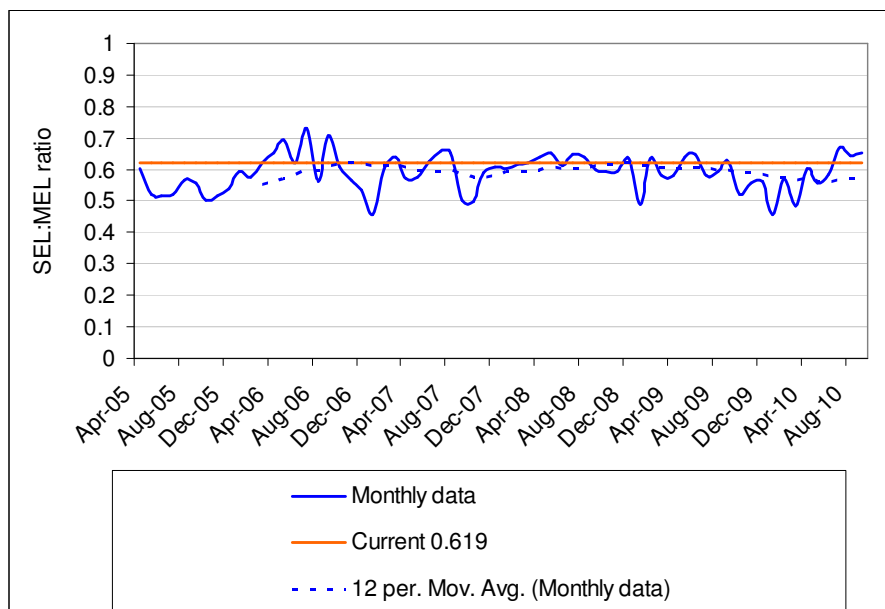

Figure 12: Historic SEL: MEL Ratio

- Static frequency response/ FFR

Forecast Volume

179. Frequency Response can be provided by either static (e.g. triggered at a set frequency level) or dynamic (constantly varying to the frequency level) providers. The volume of static and dynamic response providers for the next few years is assumed to be materially the same as the ones currently available. National Grid is working with new providers however the volumes expected from these in the next two years are unlikely to be significant. The forecast assumes that all current providers remain available as we have no information to indicate otherwise.

Response Multiplier

180. The response requirement to meet NETSSQSS requirements is converted to a volume of BM response actions using a multiplier, based on the response capability of the GB generation fleet, taking account of historical performance according to the following formula:

$$\text{Response Volume} = \text{Response Requirement} / \text{Response Multiplier}$$

181. The multiplier used for low frequency response is 0.55. This is the average response delivered per MW of headroom across the GB generation fleet and therefore a mathematical function of generation unit frequency response capabilities. For example if the largest loss of generation on a day gives rise to a response requirement of 1320MW then, based upon the multiplier of 0.55, 2400 MW of responsive generation headroom will be needed to cover this loss.
182. As this 0.55 parameter is based on the physical characteristics of the generating units connected to the system, it is not forecast to change materially during the two year incentive scheme period and is proposed as an ex-ante input to the margin volume model.

Section 3 Modelling

Static Frequency Response/ FFR Availability

183. An 80% availability percentage for response providers is to be employed in the margin model which reflects the historical average declared availability of contracted static response providers as a percentage of the contracted level. This figure is based on an empirical observation and only applies to the static response providers. It is forecast to remain at this level for the duration of the 2011/13 BSIS.
184. Therefore, in the case of static Frequency Response/ FFR, any contracted MW above historic levels should decrease the forecast margin volume by a function of the response multiplier, the SEL:MEL ratio and the static provider availability percentage.
- Reserve for Wind Requirement (%)
185. Reserve for wind requirements is currently set at every clock change alongside reserve levels required for conventional generation losses and demand forecast errors and is reviewed constantly. Reserve levels are determined to cover for demand forecast errors and generation losses and any wind component volatility is part of an additional wind reserve requirement to cover wind forecast errors. The reserve requirement is set so that there is a 1 in 365 chance that the demand could exceed available generation. As the generation mix changes, the risks change and therefore the reserve level changes.
186. Historically wind reserve levels have been set to a % of the forecast wind output which means that the normal level of reserve is increased by this % of wind forecast. At present, given current connected capacity, the wind forecast error is managed by free market headroom and margin actions taken near to real time as it is, in practice, dominated by demand forecast error and plant loss.
187. Given the uncertainty around reserve requirements over the next two years, the wind reserve factor to manage potential errors that are going to increase as the installed capacity increase is broken down in Table 7 below based on the forecast NIV expectations, 1 in 365 wind error % expectation across all forecast wind levels and the capacity that is expected to be visible to National Grid:-

Period From	Average Transmission Connected Wind Capacity MW	Ex-ante Wind Reserve Policy %
Summer 2010	1872	0
Winter 2010-11	2800	28
Summer 2011	3800	35
Winter 2011-12	4500	35
Summer 2012	5800	45
Winter 2012-13	6500	45

Table 7: Ex-ante Reserve for Wind Policy % for 2011-13 (and current %)

188. Therefore, to cater for the expected increase in wind capacity over the incentive period, the percentages in the right-hand column of the above table are proposed as ex- ante inputs to the Margin Volume model.
189. As explained above, the mechanism for wind is based on the current policy for increasing the reserve requirement according to the real time forecast of wind output, so that 1 additional MW of mean wind output in a month would increase the margin volume by α (the additional

Section 3 Modelling

reserve for wind policy percentage as set out above) x 12 hours of actual margin increase¹⁸ x 30 days of actual margin increase x 0.572 SEL to MEL ratio = α x 206¹⁹ MWh per month.

Constrained Margin Management

190. In addition to the above elements, a volume of margin actions related to the volume of sterilised headroom behind export constraints is taken into account (Constraint Margin Management or CMM). This element is included in the margin model in order to reflect the interaction between constraints volumes and margin cost. For example, margin actions (and therefore the cost of such actions) would not be required to replace sterilised headroom behind an export constraint if that constraint did not exist.
191. Historically this CMM volume was forecast based on a linear regression of the volume of Scotland export constraints (the same analysis showed a very weak relationship with volume of export constraints in England & Wales).
192. Following revision of this analysis it is proposed that a cubic regression model (as opposed to a linear model) be employed for CMM in order to better reflect unprecedented high levels of Scotland export constraint volumes observed during July, August and September 2010 respectively. The graph in Figure 13 displays the cubic regression along with the coefficients which are to be agreed as an ex-ante element of the margin volume model.

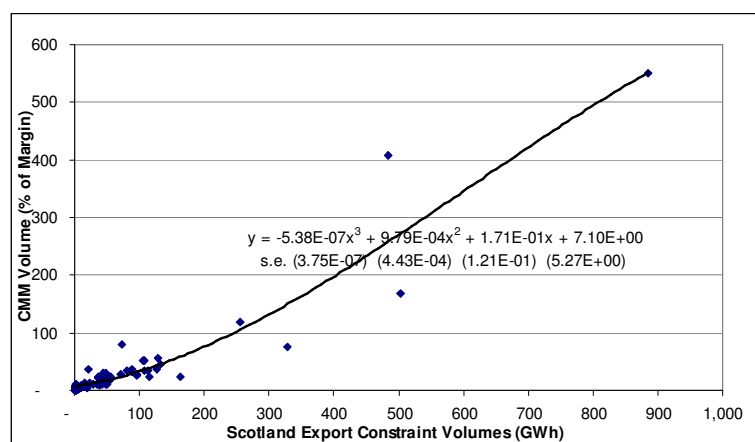

Figure 13: Cubic CMM and Scotland export constraints volume regression

193. The graphs below in Figure 14 illustrate the improvement (i.e. a better fit of the data) that the cubic regression makes over the linear regression where the lower section of the graph has been magnified (left-hand side is linear and right-hand side is cubic). It is therefore proposed that this ex-ante relationship between historic Scotland export constraint volumes and CMM volume is incorporated into the Margin Volume model.
194. Thus in order to derive a monthly volume for CMM, the above regression is used in conjunction with an ex-post assessment of constraint volumes which then gives an overall percentage of margin for CMM. This percentage is applied to the total margin volume forecast (i.e. the aggregated monthly outcome of the margin volume regression as adjusted by the monthly wind, STOR and static frequency response/ FFR elements) to determine a monthly CMM volume forecast.

¹⁸ Although the policy is applicable through the whole day, it is expected that in reality the requirement would bite during peak (or extended peak) hours. This parameter is defined as part of the normal reserve setting exercise undertaken by National Grid and is continuously reviewed to ensure appropriate levels of system security.

¹⁹ E.g. if $\alpha = 15\%$ then 30.9 MWh per month.

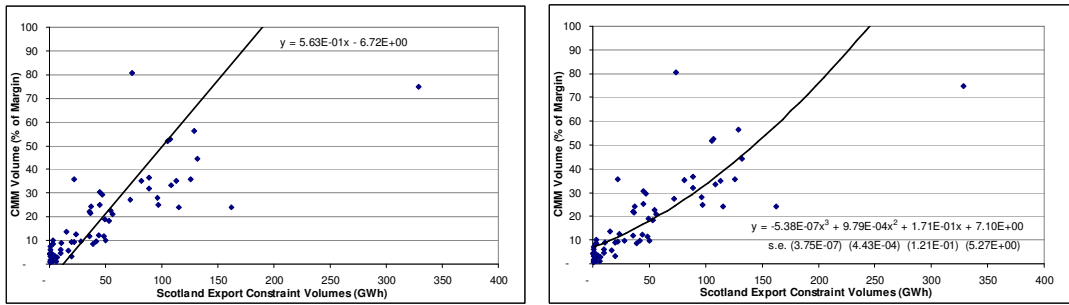

Figure 14: CMM regressions – linear (left) versus cubic (right)

Margin Volume Model Ex-post Inputs

195. The ex-post inputs to the margin volume model are NIV, Headroom and wind generation output, which are all extracted from NED.

Margin Volume Model Summary

196. The margin volume model therefore comprises the following sub-elements:
- An ex-ante relationship using margin volume, NIV and Headroom where NIV and Headroom values are input ex-post usual actual data
 - Contracted STOR volumes, Static frequency response/ FFR volumes and a reserve for wind percentage policy which are all ex-ante in the model (in combination with wind generation output which is to be input ex-post)
 - An ex-ante relationship between constraint volumes and the CMM volume (as a percentage of margin)

Margin Price

Margin Price Model Overview

197. The proposed Margin Price model is illustrated in Figure 15 below where an ex-ante relationship is employed using a number of ex-post inputs to determine a half-hourly forecast margin price. The model is described in more detail in the following section.

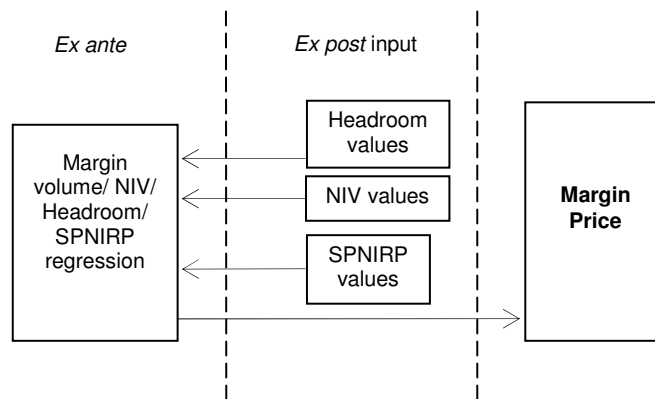

Figure 15: Margin Price Model

Margin Price Model Parameters

198. In order to reflect that lower margin volumes (i.e. longer markets combined with high levels of headroom) do not require National Grid to move so far up the generation price stack (i.e. do not need to run more expensive oil plant), margin price was originally modelled as a function of power price and historical margin volume. However, this approach has not provided satisfactory back testing results against actual historical data (which are shown in the graph in

Figure 16 below). The poor performance of the model over Winter 2008/9 and from April 2010 onwards is particularly worthy of note.

199. Further work is therefore being undertaken to see if a more appropriate margin price regression can be found. One potential option being considered, in the event that a satisfactory regression can not be found, is to look at ex-post treatment of margin price.

5 year regression back test

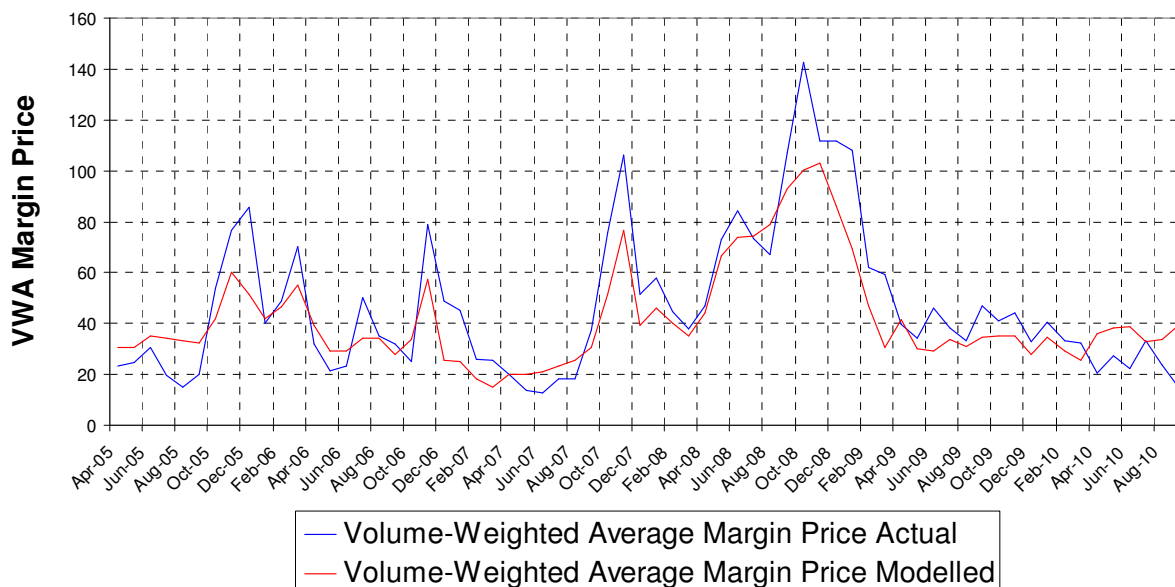

Figure 16: Margin Price Regression back testing using SPNIRP

200. In the meantime, however, in the same way as the margin volume model, the margin price model currently consists of a proposed regression of NIV, headroom and margin volume with power price (SPNIRP) included into the regression. This is because, for example, in times of market stress (shorter markets and low levels of headroom) the price of margin will be higher.

Margin Price Model Ex-ante inputs

201. There are no direct ex-ante inputs to the margin price model. However, the margin volume/ NIV/ Headroom/ SPNIRP regression will need to be agreed prior to the start of the scheme and is therefore considered to be ex-ante.

Margin Price Model Ex-post inputs

202. The ex-post inputs to the margin price model are:
- NIV and headroom values which are to be obtained from the NED
 - SPNIRP (the single price net imbalance volume reference price for each settlement period and is calculated in accordance with the Transmission Licence)

Margin Price Model Summary

203. The Margin Price model therefore comprises an ex-ante modelled relationship between historic margin volume, NIV, Headroom and SPNIRP where NIV, Headroom and SPNIRP are input ex-post to the model using actual data.

Margin Cost

Margin Cost Model Overview

204. In order to determine a total forecast cost for margin, the half-hourly outcome from the margin volume regression is firstly multiplied with the half-hourly outcome of the margin price regression. The result of this calculation is then aggregated to achieve a monthly cost of

Section 3 Modelling

margin. Following this calculation, further contract costs are included to achieve a total margin cost. These additional margin cost elements are detailed in the following sections.

205. A diagram illustrating the Margin Cost model is illustrated in Figure 17 below:

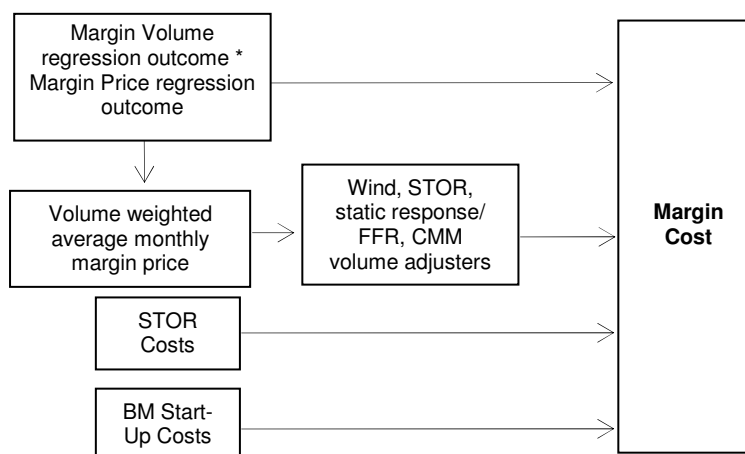

Figure 17: The margin cost forecast model

Margin Cost Model Parameters

206. As summarised by paragraph 204 in the summary section above, a monthly margin cost is calculated by multiplying the outcome of the margin volume regression with the outcome of the margin price regression.
207. Adjustment is then made in the margin cost model for the wind, STOR, static frequency response/ FFR and CMM elements which were set out in the Margin Volume model section above. These margin volume adjustments are costed using a volume monthly margin price (volume weighted average). This means that the half hourly volume and price regression outcomes are firstly multiplied and aggregated to obtain an initial monthly margin cost and volume which are then used to determine this volume weighted average monthly margin price.
208. This adjustment is made to reflect the effect that contracting for STOR and static frequency response/ FFR changes the requirement to take actions in the BM. For example, contracting for more STOR will reduce the need to synchronise units in the BM.
209. STOR contract costs and BM Start Up costs are also to be included in the Margin Cost model. STOR contract costs are to be forecast ex-ante as they have been previously for BSIS. BM Start Up costs are to be determined using an ex-ante relationship with the total cost of operating reserve.

STOR

210. The forecast cost of contracted STOR is simply the multiplication of the contracted volume (as set out above in the margin volume model section) and a forecast price for STOR. Since STOR is a market tendered service, a specific assumption on where National Grid expects prices to outturn over the next two years is not included in this consultation as it may influence future tender prices. However, a forecast contract price for STOR has been determined by examining the volume weighted prices paid since the STOR service was introduced in 2007. This is then projected forward whilst taking into account recently contracted long term STOR and forecast RPI indexation.

BM Start Up

211. BM Start Up relates to actions taken by National Grid to position generation units with longer 'notice to synchronise' times into a state of readiness through 'warming' the units to ensure that they are available to the system operator if required for margin. These units require additional payments in order for them to become ready for despatch in system operation timescales. The additional payments made under the BM Start Up service are therefore taken into account when forecasting the cost of margin.
212. Previously the cost of BM Start Up actions was modelled as a function of the volume of actions on oil fired plant as these were typically the units called upon to provide such actions. However, as shown by the graph in Figure 18, the volume of actions taken on oil fired plant has diminished over the last year. It is therefore proposed that the cost of BM Start Up is instead modelled as a function of the total cost of operating reserve which displays a more robust relationship.

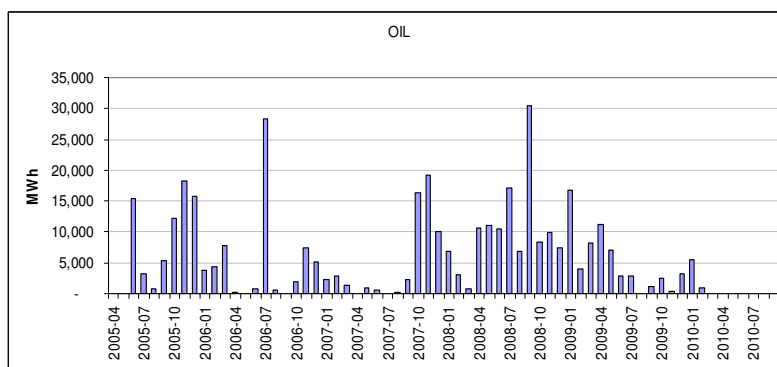

Figure 18: Volume of margin actions on oil units

213. The revised BM Start Up cost function, calculated as a proportion of overall operating reserve costs, has the variable coefficients set out in Appendix A which have been derived via a linear regression. This relationship is to be ex-ante within the Margin Cost model.
214. The graph from the above calculation, and back testing thereof, can be found in Appendix A where data only after November 2006 is employed as this is when the BM Start Up product was introduced, replacing the old Warming service (which was a structurally different service).

Margin Cost Model Summary

215. In summary, the margin cost forecast model is a function of the margin volume and margin price regression outcomes with the addition of costs for STOR and BM Start Up, where the forecast for STOR and BM Start Up are determined ex-ante. Margin Cost can therefore be summarised by the following formula (where 'Σ' refers to aggregating half-hourly values to monthly values):

$$\begin{aligned}
 \text{Margin Cost} &= \Sigma(\text{Modelled Margin Volume} \times \text{Modelled Margin Price}) \\
 &+ \text{Volume Weighted Price} \times \text{Volume Adjustment} \\
 &+ \text{Volume Weighted Price} \times \text{Modelled CMM \%} \times \Sigma\text{Modelled Margin Volume} \\
 &+ \text{STOR} \\
 &+ \text{BM Start- Up}
 \end{aligned}$$

Margin Incentive

216. The incentive for this component remains on:
- The STORR setting stage, including the assessment of reserve requirements for wind
 - Achievement of at least the same level of efficiency in the prices accepted in the Balancing Mechanism, i.e. trying to match or beat the historic BM price premium over wholesale power prices

- Efficient contracting of STOR units
- Efficient contracting of Frequency Response FFR/Static units including the development of contract terms and attracting new providers into the market

Question 9: To what extent do you think that National Grid's proposed approach to delivering a modelled target cost for Margin will act as an appropriate incentive to deliver cost efficiencies?

3.1.4 Remaining Energy Components

217. To arrive at the most appropriate models for the remaining energy components (Fast Reserve, Frequency Response and Footroom), a series of analysis have been undertaken to test the relevance of the inclusion of a number of 'candidate' variables or variables which are believed to have some relationship with the cost category in question. These candidate variables, listed below, form a subset of those variables mentioned previously in this document:

- a) Market imbalance levels (NIV)
- b) Market self dispatched reserve (Free Headroom)
- c) Wholesale power price (SPNIRP)
- d) Inflexible generation output (Nuclear output)
- e) Intermittent generation output (Wind output)
- f) Power flow through the transmission system (Demand)
- g) Seasonal effect in electricity consumption (BST effects)
- h) Daily variances in electricity consumption (EFA blocks sensitivity)
- i) Consistent increase or decrease in any of the above (time trends)

218. The selection process for variables has been undertaken by testing how the overall model's 'fitness' or reflection of real costs is improved after the inclusion of a new candidate variable and how significant the coefficient is for the new variable.

219. The Fast Reserve, Frequency Response and Footroom models are described in turn below.

Fast Reserve

220. Fast Reserve costs relate to the contracting and use of generation and demand units to assist in the management of rapid demand changes. Volumes of actions taken in the BM for Fast Reserve are split into volumes of offers and volumes of bids. Fast reserve prices, and therefore costs, are mostly dependent on tendered (and accepted) prices, submitted by service providers (Fast Reserve Ancillary Service costs).

221. There have been two developments made to the Fast Reserve cost forecast model since the model was used to forecast a cost for the 2010/11 BSIS. The first is that wind generation output has been included as a variable within the model regressions. Whilst the relatively low materiality of wind volatility on the system to date has resulted in minimal impacts to Fast Reserve costs, it is recognised that levels of wind generation and therefore wind volatility on the system are likely to grow in the future and therefore have an impact upon Fast Reserve requirements in order to manage wind intermittency. It also means that, as for the margin model (and as set out in Section 1), wind output can be included in the model as an ex-post input. The inclusion of this wind variable is particularly important when considering a longer term BSIS for this cost element.

222. The second development is that the Fast Reserve model has been simplified to the following three sub-models (two for costs associated with actions taken in the Balancing Mechanism and one for contract (or Ancillary Services) costs:

- BM Fast Reserve Bid costs
- BM Fast Reserve Offer costs

Section 3 Modelling

- Fast Reserve Ancillary Services (AS) costs

223. Whilst attempts have been made to develop a suitable model to forecast prices paid in the Balancing Mechanism for units contracted to provide the Fast Reserve service, no such solution has been found. It is therefore proposed that 12 month historical price data be used as forecast Fast Reserve BM prices which will be determined ex-ante.
224. The Fast Reserve model therefore uses the relationship between historical BM prices and BM volumes in order to determine the cost of Fast Reserve associated with BM actions.
225. Each of the three sub-elements to the Fast Reserve model is explained in turn below.

BM Fast Reserve Bid Costs

226. The forecast of costs associated with BM Fast Reserve bids is achieved by the multiplication of the forecast bid volume and forecast bid price. In order to determine the Fast Reserve bid volume, a historical ex-ante time trend is to be employed in conjunction with wind generation output as an explanatory (ex-post) variable. The coefficients for this bid volume model are set out in Appendix A.
227. In order to determine a forecast Fast Reserve bid price, the historical price of footroom has been examined since BETTA Go-Live. Historic footroom prices have been used because the use of Fast Reserve bids has declined in recent months and therefore BM Fast Reserve bid price data is too sparse to model. However, if Fast Reserve bids were to be taken, they would be used for the same reason as footroom bids i.e. fast reserve bids would also desynchronise a generating unit.
228. It is proposed that, for the purposes of the BM Fast Reserve bid cost model, the forecast Fast Reserve bid price is defined as a stand alone ex-ante parameter. The graph in Figure 19 shows the historical footroom price data.

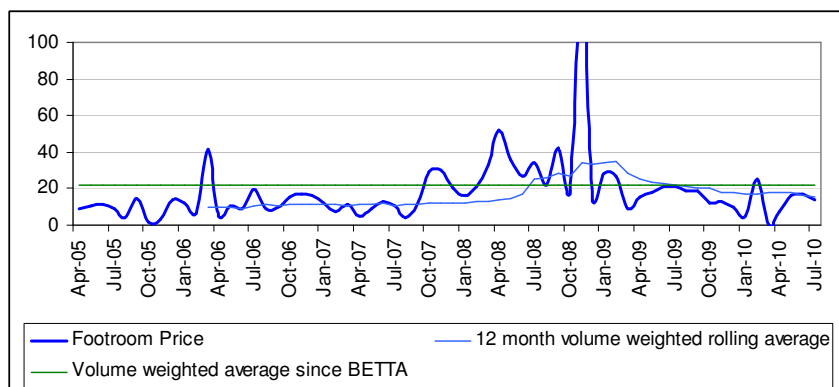

Figure 19: BM Fast Reserve bid prices since BETTA Go-Live

229. As can be seen from the graph above, the volume weighted average price since the introduction of BETTA has remained relatively stable. It is therefore proposed that this figure, of £22/ MWh, is used in the Fast Reserve bid cost model for the 2011-13 BSIS.
230. The diagram in Figure 20 illustrates the Fast Reserve Bid cost model, incorporating both the volume and price elements:

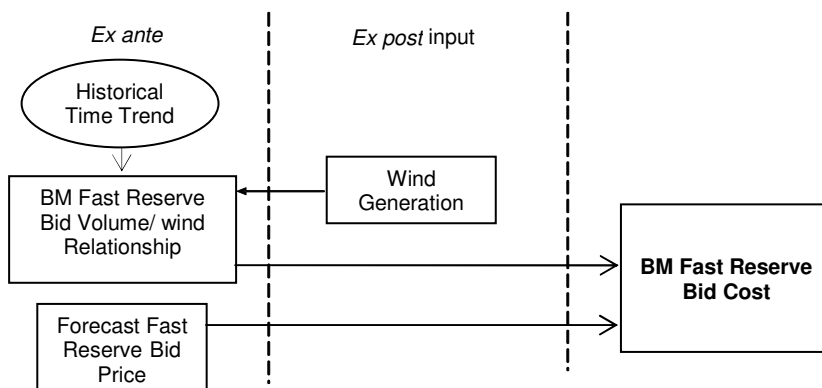

Figure 20: The BM Fast Reserve Bid cost model

BM Fast Reserve Offer Costs

- 231. As for the BM Fast Reserve Bid cost model, the BM Fast Reserve Offer cost model also comprises a volume element and a price element. In order to determine the Fast Reserve offer volume, a historical offer volume ex-ante trend is to be employed in conjunction with wind generation output as an explanatory (ex-post) variable. The coefficients for this offer volume model are set out in Appendix A.
- 232. In order to determine BM Fast Reserve offer prices, historical offer prices since the introduction of BETTA have been examined. It is proposed that the forecast Fast Reserve offer price is defined as a stand alone ex-ante parameter. The graph in Figure 21 shows the historical offer price data.

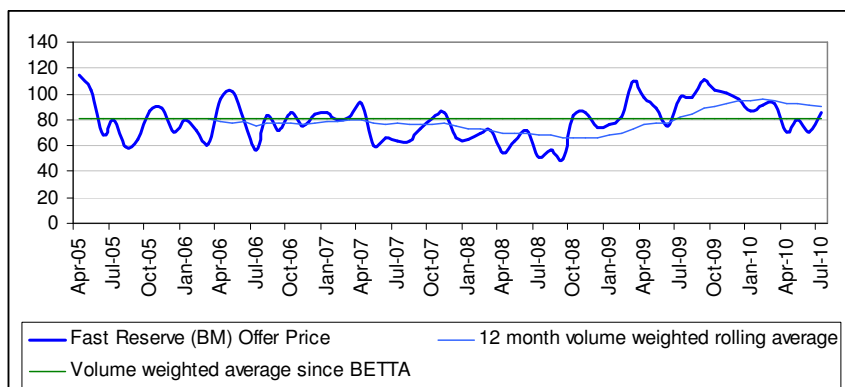

Figure 21: Offer prices for Fast Reserve since BETTA Go-Live

- 233. The above graph shows that the 12 month volume weighted rolling average has not varied significantly over the five years, even though power and commodity prices experienced large swings over the same period. It is therefore proposed that the volume weighted rolling average be used in the BM Fast Reserve Offer cost model in the 2011-13 BSIS which is £90/MWh.
- 234. The diagram in Figure 22 illustrates the Fast Reserve Offer cost model, incorporating both the volume and price elements:

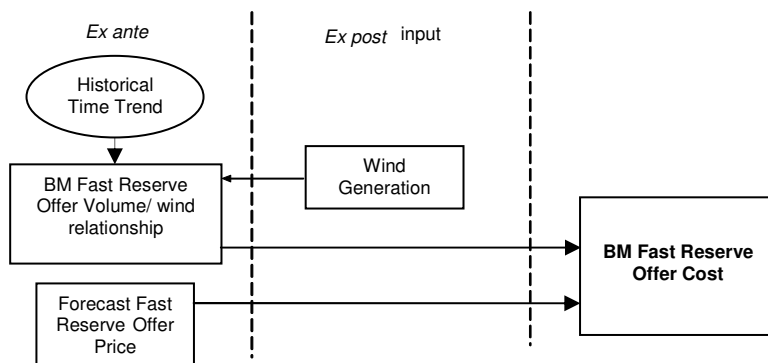

Figure 22: The BM Fast Reserve Offer cost model

Fast Reserve Ancillary Services (AS) Cost

235. The forecast cost of Fast Reserve associated with ancillary services contracts is similarly modelled using average wind output as an ex-post input to capture a volume element but also includes SPNIRP in the regression to reflect contract pricing of the service. Summer and Winter coefficients reflect seasonal changes in volume (lower in the Summer) and price (higher in the Winter). The coefficients of the Fast Reserve Ancillary Cost regression can be found in Appendix A.
236. A diagram of the Fast Reserve Ancillary Services cost forecast model is illustrated in Figure 23 below:

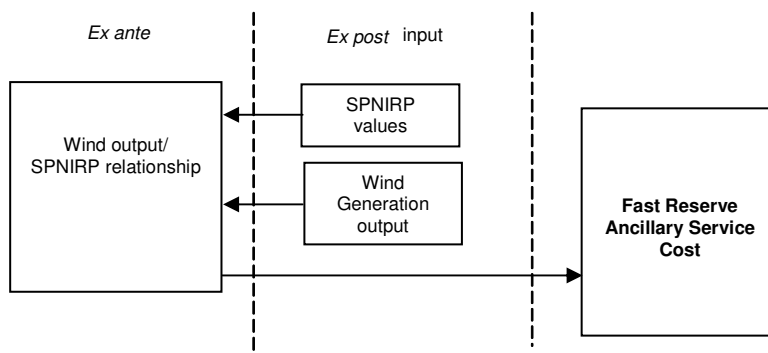

Figure 23: The Fast Reserve Ancillary Service Cost model

Fast Reserve Model Ex-ante Inputs

237. The ex-ante inputs for the Fast Reserve model are therefore:
- A forecast BM Fast Reserve Bid price of £22/MWh
 - A forecast BM Fast Reserve Offer price of £90/MWh
 - The sub-elements for BM Fast Reserve bid and offer costs also include an ex-ante historical time trend

Fast Reserve Model Ex-post Inputs

238. The ex-post inputs to the Fast Reserve model are therefore SPNIRP and wind generation output data which are all extracted from the NED system.

Fast Reserve Model Summary

239. The total Fast Reserve forecast cost is determined by the summation of the outcomes of the three sub-models described above; namely Fast Reserve Bid cost, Fast Reserve Offer cost and Fast Reserve Ancillary Services cost.

Fast Reserve Incentive

240. The incentive for this component remains on achieving at least the same efficiency levels of real time operation as historical levels and on the pursuit of more favourable contracting conditions with Fast Reserve providers.

Question 10: To what extent do you think that National Grid's proposed approach to delivering a modelled target cost for Fast Reserve will act as an appropriate incentive to deliver cost efficiencies? Are there any areas where you think that improvements to the models could be made?

Frequency Response

241. The requirement for frequency response is prescribed to ensure that sufficient changes in energy output are delivered to arrest falls or rises in frequency in the event of sudden loss of generation or demand. The requirement is driven by the largest system loss permitted by the NETSSQSS and system demand. The requirement for response is met from generators as a mandatory service and from commercial services remunerated via tenders from generation and demand side providers.
242. Previously, the model to forecast the cost of Frequency Response included the input of different ancillary services contract volumes and costs, the largest infeed loss on the system, demand forecast and the volume of frequency response left to be procured via the mandatory mechanism.
243. The Frequency Response model has been improved to accommodate the ex-post input of SPNIRP and NIV to model BM prices (as for the Energy Imbalance Model). The model has also been simplified to five ex-ante regressions to define the following elements:
1. The total contract costs for Response (Ancillary Services (AS) Response)
 2. The volume of BM Offers required to position units so they can provide high frequency response (BM Response Offers Volume)
 3. the price paid for the above volume of BM Offers (BM Offers Price)
 4. The volume of bids required to position units so they can provide low frequency response (BM Response Bid Volumes)
 5. the price paid (out of merit cost, which transforms a bid from an income into a cost) for the above volume of bids (BM Response Bid Prices)

Frequency Response Model Parameters

244. The above elements were derived using monthly data using regression analysis. The variables for each regression are set out in turn, presented in the same order as above.

Ancillary Services Response Cost

245. The cost of Ancillary Services frequency response is modelled separately to response procured via the Balancing Mechanism because it allows the aggregation of many separate contract components which comprise different volume and price combinations. An element of this model uses a historic trend in order to reflect rising costs over time. This trend feeds into a regression which incorporates the outcome of both the Response Bid volume and Response Offer volume regressions (as set out in the following sections below).
246. The model has also been developed to include wind as an ex-post variable in order to capture the fact that increasing wind volatility increases the requirement to hold more frequency response. The coefficients for the Ancillary Services Response costs are set out in Appendix A.
247. The Ancillary Services cost model is illustrated in the diagram in Figure 24 below.

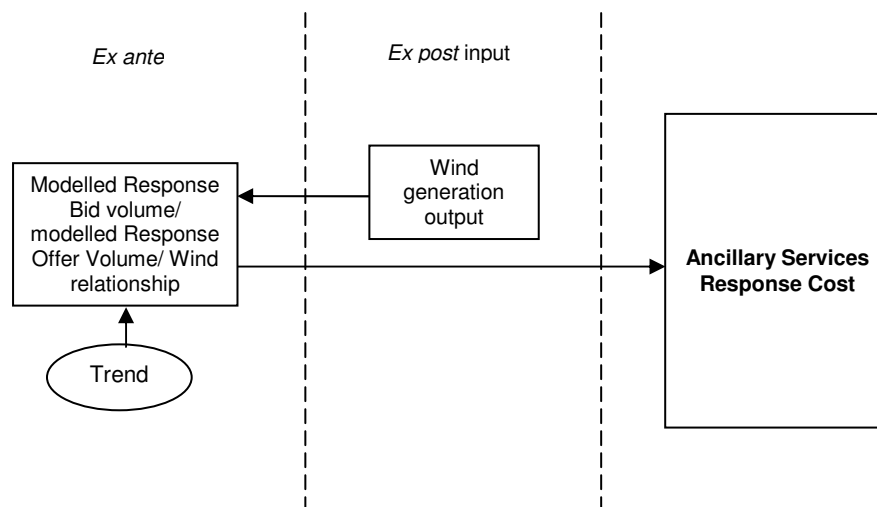

Figure 24: The Ancillary Services Frequency Response cost model

BM Response Offer Volume

248. The BM Response Offer volume model looks to forecast the volume of offers that National Grid will have to take in the BM in order to position units to provide high frequency response. The variables used in the regression to determine this volume are as follows for which the coefficients can be found in Appendix A:

- Nuclear generation
- Wind output
- NIV
- Demand
- Headroom

249. The level of inflexible generation, namely wind and nuclear, is used in this model because these types of generation typically do not provide frequency response and are already providing maximum output. Any additional high-frequency response capability required in periods of high wind and/ or nuclear output is created by repositioning more flexible generation to give the necessary downward capability. The level of NIV and headroom is important because, for example, in a short market (positive NIV), more offer volume will be required for frequency response, but the available headroom might not permit sufficient offers to be taken without synchronising additional generation.

250. Lastly, the level of demand will determine the response holding volume required. For instance the lower the demand level, the more high frequency response holding is required because any demand loss has a higher relative impact on the resultant system frequency change.

BM Response Offer Price

251. Prices submitted in the BM for offers, and therefore the total cost of taking these offers, are related to wholesale power prices reflecting the extra fuel required to increase generation output. BM Response Offer prices are therefore modelled (on an aggregate basis) on SPNIRP which is to be an ex-post input to the model. The coefficients for the BM Response Offer Price calculation can be found in Appendix A.

BM Response Offer Cost

252. The BM Response Offer cost forecast is therefore determined via the multiplication of the outcomes of the BM Response Offer volume and BM Response Offer price calculations. A diagram illustrating the BM Response Offer cost model can be found in Figure 25 below.

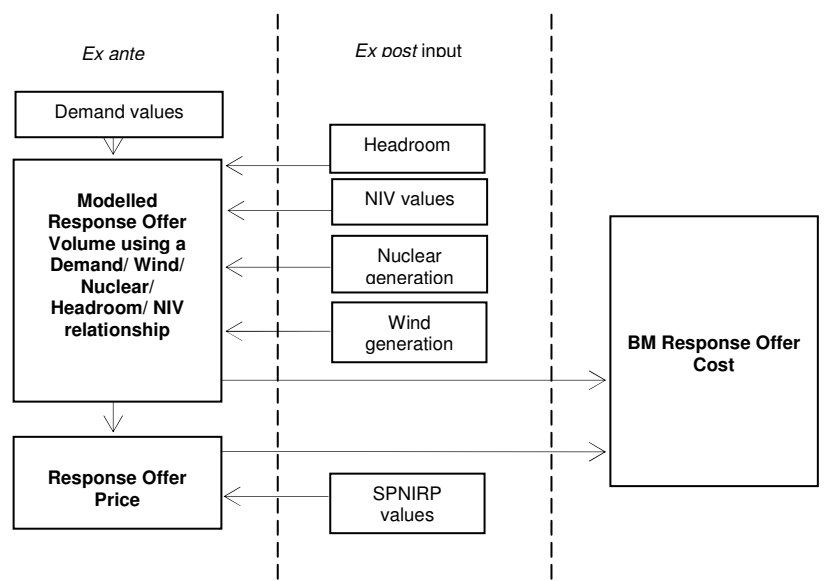

Figure 25: The BM Response Offer cost model

BM Response Bid Volume

- 253. The BM Response Bid volume model looks to forecast the volume of bids that National Grid will have to take in the BM in order to position generating units to provide low frequency response. The variables used in the regression to determine this volume are NIV and headroom which are to be input ex-post to the model, and a historic volume trend. This trend takes into account reductions in this volume over time (and is therefore negative). NIV is used in the model because, for example, in shorter markets a lower bid volume is required to establish the necessary headroom in order to provide low frequency response. More generally, the more headroom there is on the system, the lower the bid volume required because units are already self-positioned to provide low frequency response.
- 254. The variables and their coefficients for this regression can be found in Appendix A.

BM Response Bid Price

- 255. Prices submitted in the BM for bids, and therefore the total cost of taking these bids, are modelled on BM prices in relation to historic bid volume. The BM price employed in this model is the modelled BM price from the Energy Imbalance model as set out in Section 3.1.2 above. As set out in Section x, the modelled BM price is determined using SPNIRP as an ex-post input.
- 256. The coefficients for the BM Response Bid Price calculation can be found in Appendix A.

BM Response Bid Cost

- 257. The BM Response Bid cost forecast is therefore determined via the multiplication of the outcomes of the BM Response Bid volume and BM Response Bid price calculations. A diagram illustrating the BM Response Bid cost model can be found in Figure 26 below.

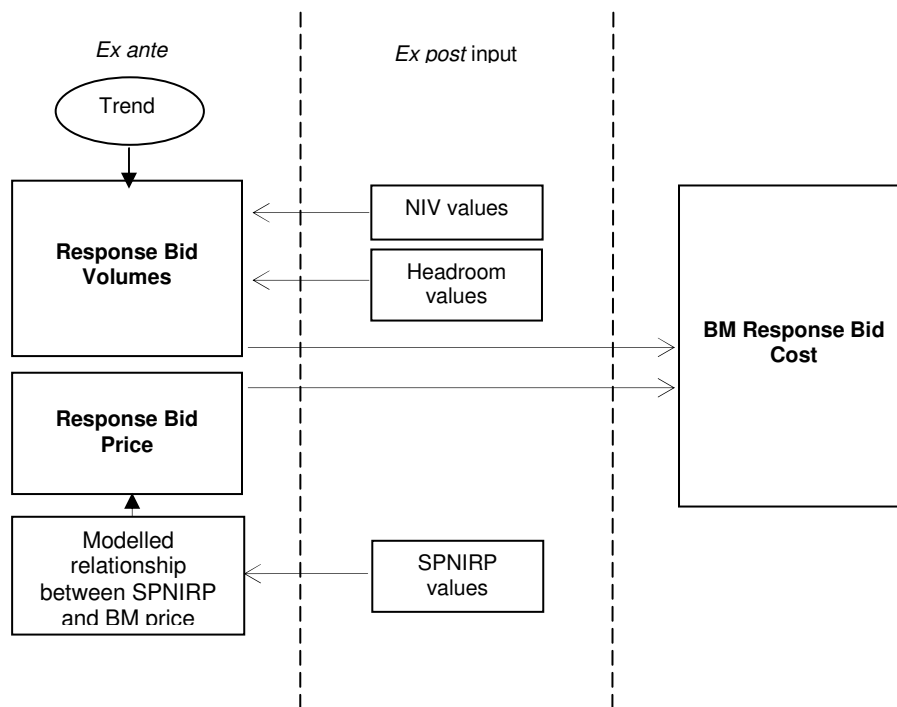

Figure 26: The BM Response Bid cost model

Frequency Response Ex-ante Inputs

258. The ex-ante input to the frequency response model is demand for which the datasets to be used is set out below.

Demand

259. The main drivers affecting demand over a long period are weather related and economic conditions. The graph in Figure 27 sets out the demand forecast dataset to be used for the scheme commencing April 2011 for the two year period and represents the central view for demand.

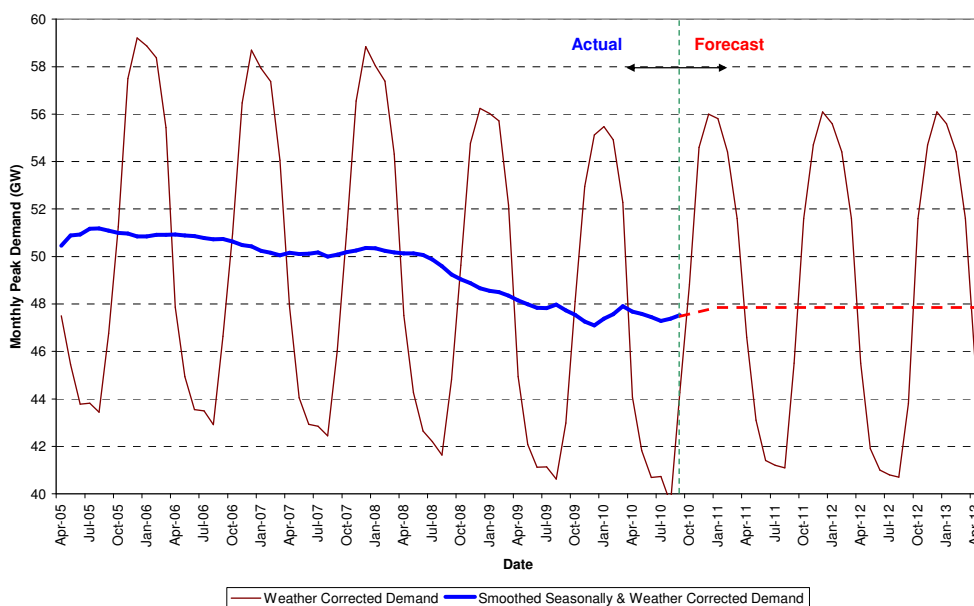

Figure 27: Demand level forecast

260. The demand forecast used in the models, and set out in Figure 27, is based on average weather (over a 30 year period) and uses underlying historical demand data from the previous three years. Based on the recent trend in demand growth/decline for weather corrected and seasonal adjusted demand, a view is taken of the future whilst incorporating national econometric data.
261. Following the recession period from April 2008 up until the fourth quarter of 2009 the demand level started to stabilise and even increased slightly until April 2010. There is added uncertainty presently due to the economic and political environment but the current average demand level is only approximately 200MW off the 2009 history. The forecast underlying demand i.e. demand absent of weather, has therefore been scaled back by this amount going forward in the forecast. Due to the current economic uncertainty we have taken a view that demand will be flat for the two year period commencing April 2011.
262. Bank holiday, Christmas and Easter demands have been included for the relevant dates in each year.

Frequency Response Ex-post Inputs

263. The ex-post inputs to the Frequency Response model are therefore as follows and are to be extracted from the NED system.
- Headroom
 - Wind generation output
 - SPNIRP
 - NIV
 - Nuclear Generation Availability

Frequency Response Model Summary

264. The Frequency Response forecast cost model is therefore a summation of the above three sub-model outputs i.e.:

Total Frequency Response cost = Ancillary Services Response Cost + BM Response Offer cost + BM Response Bid cost

Frequency Response Incentive

265. The incentive for Frequency Response remains on achieving at least the same efficiency levels of real time operation and on pursuing even more favourable contracting conditions with Frequency Response providers, bearing in mind the knock on effect of actions in this part of the scheme on the costs of Margin and Footroom actions.

Question 11: To what extent do you think that National Grid's proposed approach to delivering a modelled target cost for Frequency Response will act as an appropriate incentive to deliver cost efficiencies?

Footroom

266. Footroom (or downward regulation) actions are those taken to increase the amount of inflexible generation connected in the system so that frequency can be securely managed in periods of lower than expected demand. The volume of footroom actions required is significantly impacted by the availability and running regimes of inflexible generation, such as nuclear and wind. High levels of inflexible plant generating during periods of low demands often sees flexible generation moving toward their minimum stable output (as would be expected from the relative merit order running of such generation), thereby increasing the volume of actions required (i.e. moving some plant above the minimum position and desynchronising other generation to balance energy).

Section 3 Modelling

267. The previous footroom cost forecast model was based upon a regression analysis of the historic volume and cost of footroom. A demand level forecast and must run generation output (wind and nuclear) were used to estimate footroom volumes which were subsequently multiplied by historic unit costs to determine an overall cost forecast for footroom.
268. The main development to this model is that the level of wind generation output and nuclear generation will be input to the model ex-post.
269. The volume of footroom required on the system each month is therefore driven by, and modelled using, the following variables:
- Demand
 - Nuclear generation
 - Wind generation (capacity and load factor)

Footroom Model Parameters

270. The coefficients for the regression using the above variables to determine footroom volume and the back testing thereof are set out in Appendix A.

Footroom Price

271. In order to establish a forecast cost of footroom, the forecast volume ascertained via the footroom volume regression is multiplied by a forecast price. The forecast footroom price is to be determined ex-ante based upon historic footroom prices. Analysis has been undertaken to find a model to deliver a prediction of prices for footroom actions, however, nothing suitable has been found. The graph in Figure 28 shows historic footroom prices since the introduction of BETTA.

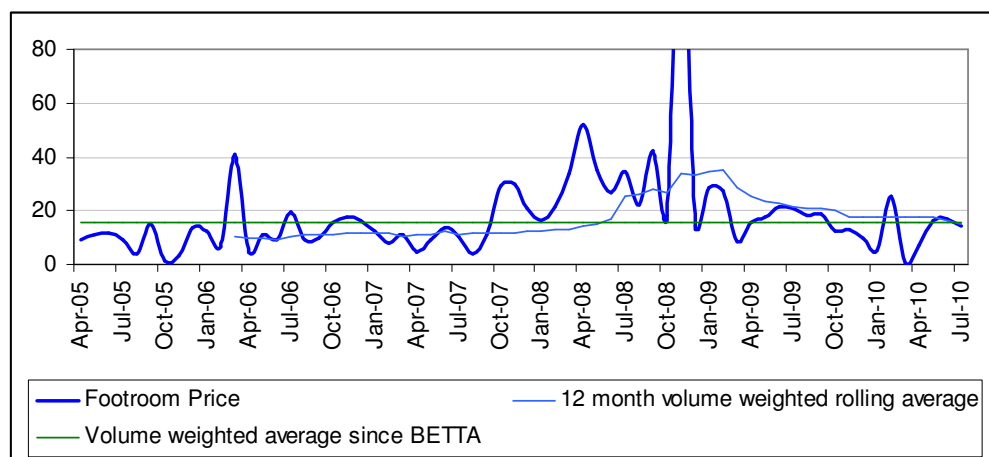

Figure 28: Footroom prices since BETTA Go-Live

272. Looking at the graph above, the 12 month volume weighted rolling average price coincides with the volume weighted average price since BETTA at circa £15/ MWh. It is therefore proposed that this price be an ex-ante input the footroom cost forecast model.

Footroom Model Ex-ante Inputs

273. The ex ante inputs to the Footroom model are Demand (for which the dataset to be used is detailed in the Frequency Response model ex-ante inputs section) and a forecast footroom price of £15/MWh.

Footroom Model Ex-post Inputs

274. The ex post input to the footroom model is wind generation output and nuclear availability which are to be obtained from NED.

Footroom Model Summary

275. A diagram of the footroom model is shown in Figure 29 below. The model comprises an ex-ante regression of demand, nuclear and wind output using ex-post input of wind and nuclear to determine a footroom volume which is then multiplied by a forecast footroom price.

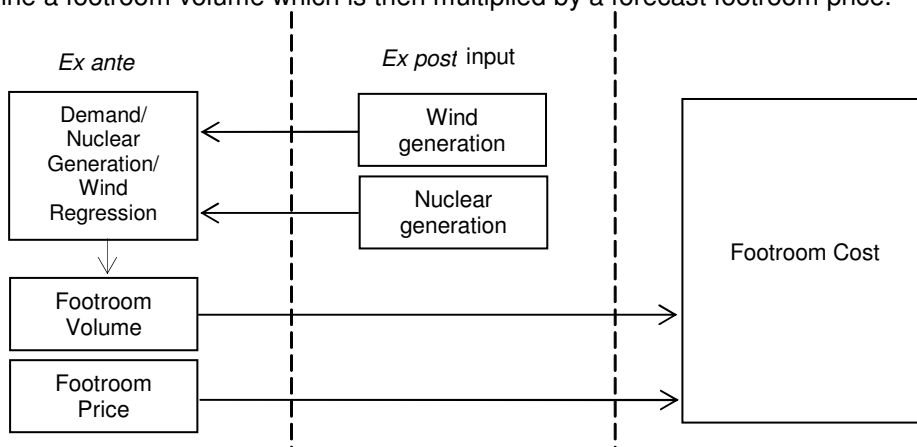

Figure 29: The footroom model

Footroom Incentive

276. The incentive for Footroom (also known as Negative Reserve) is similar to that for Margin and remains on:
- The STORR setting stage
 - Achievement of at least the same level of efficiency in the prices accepted in the Balancing Mechanism, i.e. trying to match or beat the historic BM price premium over wholesale power prices
 - Efficient contracting of overnight Frequency Response FFR units
277. Specific actions that National Grid may take to mitigate the effects of footroom costs include the use of pre-gate actions to achieve lower prices than those in the BM; the assessment and recalibration of high frequency response parameters resulting in a reduction in the volume of bids and offers required in the BM; and the sale of energy via the French interconnector which effectively raises system demand as an alternative to desynchronising generation.

Question 12: To what extent do you think that National Grid’s proposed approach to delivering a modelled target cost for Footroom will act as an appropriate incentive to deliver cost efficiencies?

Reactive Power

278. The transmission system uses alternating current which results in reactive power production and consumption. Reactive power is managed on a locational basis through the generation and absorption of MVArS and is essential for maintaining voltage levels within designated limits across the transmission system. The volume of reactive power procured by National Grid depends on the system demand and the overall configuration of the transmission system at that time.

Reactive Volume Calculation

279. Currently, the Reactive model employs an observed relationship between historic active demand and reactive demand volumes to forecast a reactive volume, whereby active demand is obtained from the normal demand forecasting process within National Grid (see the Frequency Response model ex-ante inputs for more details).

**Section 3
Modelling**

- 280. Following the review of the energy models, there are minimal amendments being proposed to the structure of the reactive power model.
- 281. The methodology employed last year²⁰, as illustrated by the graph below in Figure 30 examined the ratio between Lead volumes and the inverse of demand (blue line, left-hand axis) and the ratio between Lag volumes and demand (orange line, right hand axis) since BETTA Go-live.

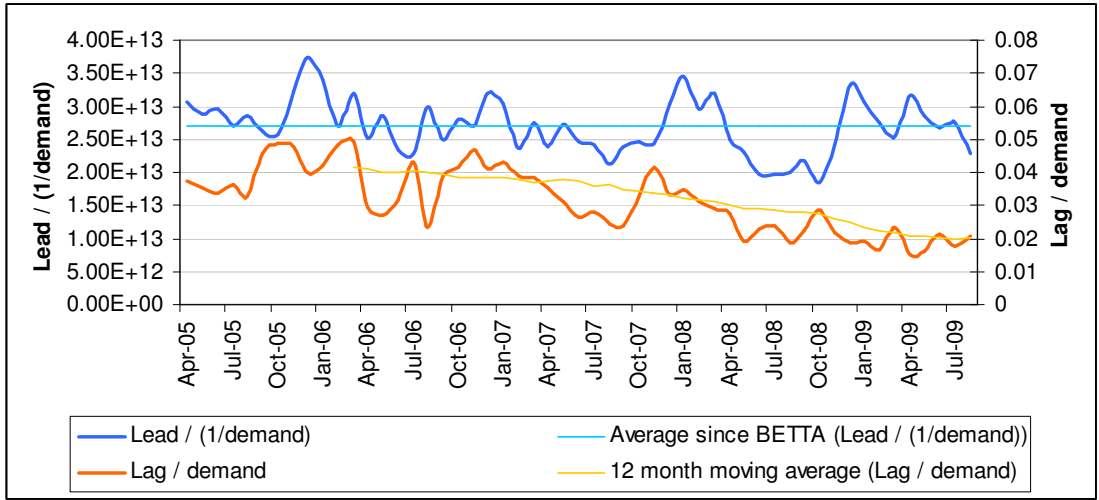

Figure 30: Reactive Power Ratios to Demand from BETTA Go-Live to October 09

- 282. Whereas last year the above analysis showed that Lag reactive (used to increase volts) was directly proportional to demand and that Lead reactive (used to reduce volts) was inversely proportional to demand, the same cannot be concluded from the latest updated results as illustrated by the graph in Figure 31 below.

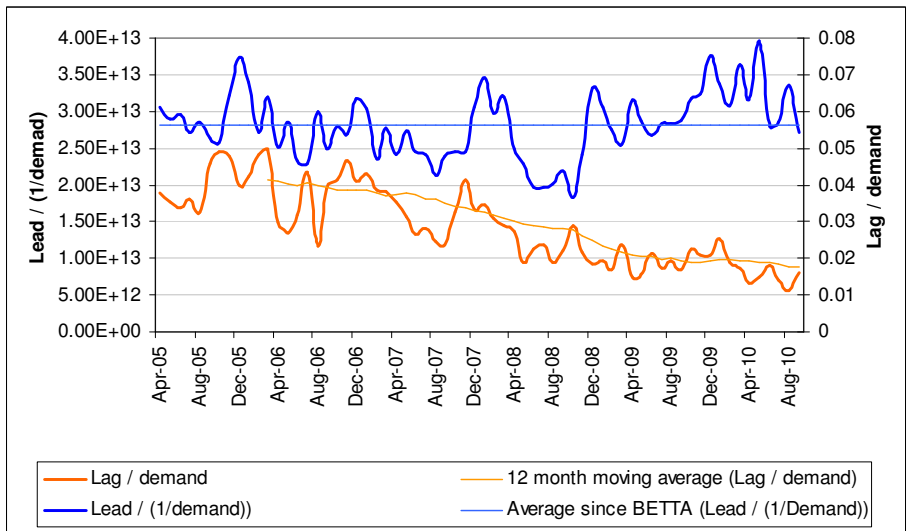

Figure 31: Reactive Power Ratios to Demand since BETTA Go-Live

- 283. In order to determine a more stable relationship between demand and reactive demand, an alternative methodology is being proposed which uses just one of the lines from the graph above instead of both. Therefore, in order to determine a forecast for reactive demand volumes a calculation has been carried out whereby total (gross) historic reactive volume is

²⁰ This analysis can be found on page 68 of the 2010/11 BSIS Initial Proposals Consultation Document: <http://www.nationalgrid.com/NR/rdonlyres/519DEB34-5CCE-40D6-9980-9DE23A41E666/38228/ElectricitySOIncentivesInitialProposalsConsultatio.pdf>

divided by historic demand. Figure 32 below shows the outcome of this calculation graphically and looks to display a more stable relationship.

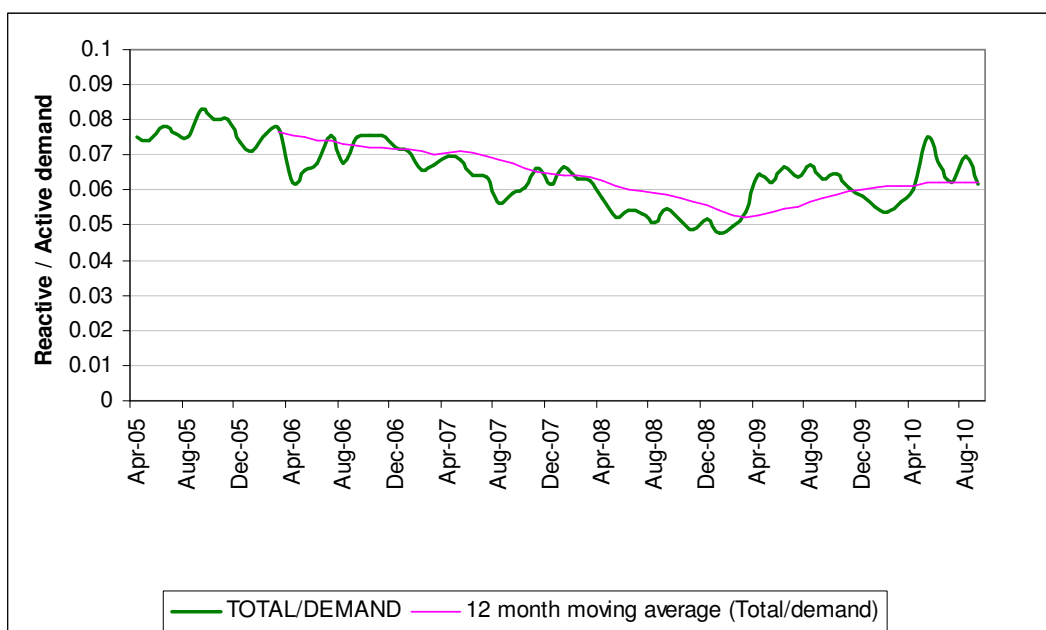

Figure 32: Reactive power Lag ratio to demand since BETTA

284. As shown in the graph above, the pink line (12 month moving average of Lag against demand) has been fairly stable across the period and in particular over the course of the last few months at around 0.06 MVar/MW. It is therefore proposed that this be used as the ex-ante reactive volume assumption for the model. The graph below in Figure 33 shows the above analysis (i.e. total reactive demand over demand) plotted across previous years and further demonstrates the stability of this relationship over time.

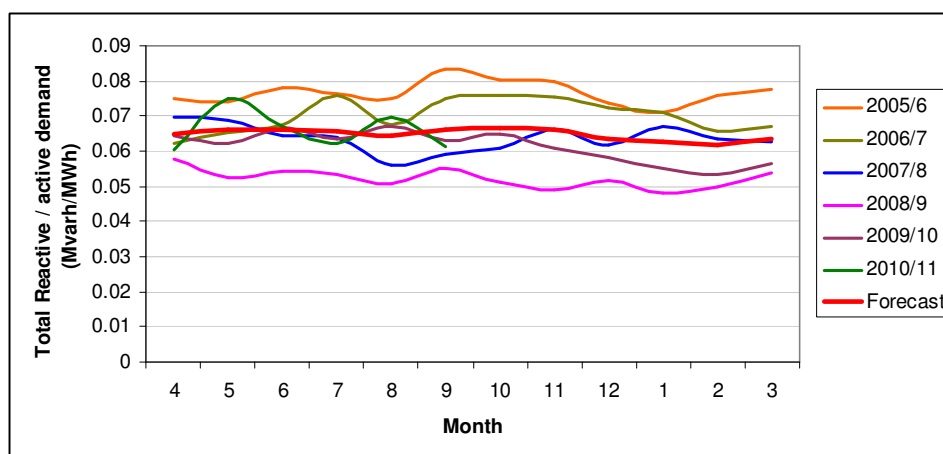

Figure 33: Forecast Reactive Power Volumes based upon Total Reactive Demand

Reactive Power Price

285. In terms of the price paid for reactive volume, Schedule 3 of the CUSC sets out the calculation for the default price for reactive power provision. The default price will therefore continue to be determined ex-ante by the CUSC where RPI and power price are to be ex-post inputs.
286. With regard to the reactive market mechanism, an assumption will continue to be made, ex-ante, on the percentage of reactive demand sourced via market arrangements which feeds

Section 3 Modelling

into the total cost for reactive power. Again this approach is taken due to the recent and sustained decline to participation in the reactive market tender arrangements in the last four years. The converse of this is that there remains an incentive for National Grid to overhaul the existing reactive market arrangements to try and extract value from better conditions to those of the default arrangement.

Reactive Model Ex-ante Inputs

287. The ex-ante inputs to the reactive model are the demand forecast (see the Frequency Response model ex-ante inputs section for details of the demand forecast) and a forecast reactive volume to demand ratio of 0.06MVA_r/MW.
288. As set out above, due to the sustained decline of the reactive power market mechanism, it is assumed that all reactive volume will be procured via the CUSC default mechanism. The ex-ante input for volume procured via market arrangements is therefore zero.

Reactive Model Ex-post Inputs

289. The ex-post inputs to the reactive model are RPI and wholesale electricity price which are sourced, and used to calculate the default price of reactive power, in accordance with Appendix 1, Schedule 3 of the CUSC²¹.

Reactive Model Summary

290. The reactive power model therefore comprises an ex-ante forecast of demand and hence reactive demand coupled with ex-post RPI and wholesale electricity price inputs (in accordance with the CUSC reactive power default price calculation) to determine the forecast cost for reactive power. The model is demonstrated in Figure 34 below. (As stated above, it is forecast that there will be no reactive volume procured via the market arrangements and therefore the market elements in the model diagram are greyed out.)

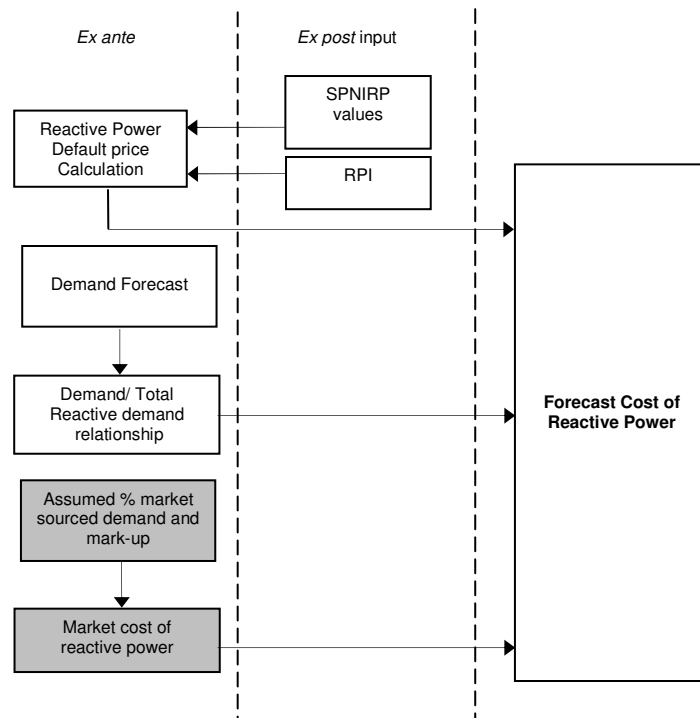

Figure 34: The Reactive Power model

²¹ A link to Schedule 3 of the CUSC: http://www.nationalgrid.com/NR/rdonlyres/513F95AA-4EBC-468E-BE70-2FA25FA5CFB0/40480/CUSC_Sch3V16_CAP173_1April2010.pdf

Reactive Power Incentive

291. The incentive for this component remains on achieving at least the same efficiency levels of real time operation and on attracting providers to an improved commercial mechanism for reactive power. Participation in the reactive power market tender process has declined in recent years. Some efforts have been made in this area to improve the reactive market arrangements e.g. CUSC amendment proposal CAP173 (reduction in tender timescales). However, a review of both the market and default arrangements could lead to an improved market mechanism for the reactive power service.
292. Incentivisation in this area could lie in the further optimisation of National Grid Control Room processes and procedures to reduce reactive power volumes and therefore costs.

Question 13: To what extent do you think that National Grid's proposed approach to delivering a modelled target cost for reactive power will act as an appropriate incentive to deliver cost efficiencies?

3.1.5 Energy Model Summary

293. As a summary, Table 8 details:

1. the relationships (regressions) and trends that form part of each model (to be agreed pre-scheme)
2. the ex-ante inputs/ datasets to those models (again to be agreed pre-scheme)
3. the ex-post inputs to each model (datasets agreed pre-scheme but actual data input each month)

Model	Ex-ante Regression/ Trend	Ex-ante inputs	Ex-post inputs
Energy Imbalance	Modelled BM Price (SPNIRP/ NIV/ BM price regression)	N/A	Wholesale electricity price (SPNIRP) NIV
Margin: Volume	Margin volume/ NIV/ Headroom regression	Reserve for wind (policy %)	NIV
		Forecast Static response/ FFR volumes	Headroom
		MEL:SEL Ratio	Wind generation
		Frequency Response multiplier factor	
		Constrained Margin Management	
	Forecast STOR contract volumes		
Margin: Price	Margin volume/ SPNIRP/ NIV/ Headroom regression	N/A	SPNIRP NIV Headroom
Total Margin Cost	Margin Volume Model outcome * Margin Price Regression outcome	BM Start Up costs STOR contract costs	N/A
Fast Reserve	BM Fast Reserve Bid volume Trend	BM Fast Reserve Bid Price	Wind generation
	BM Fast Reserve Offer Volume Trend	BM Fast Reserve Offer Price	SPNIRP
Frequency Response	Response Bid volume regression	Demand	NIV
	Response Bid price regression		SPNIRP
	Response Offer Volume Regression		Wind generation
	Response Offer Price regression		Headroom
	BM Price (SPNIRP/BM price regression)		Nuclear Generation
Footroom	Demand/ Must-run generation/ footroom volume regression	Demand	Wind generation
	Historic footroom price trend	Footroom price	Nuclear Generation
Reactive Power	Demand/ Reactive demand (lead/ lag) regression	Default price calculation (CUSC)	RPI
	% market sourced demand and mark-up	Demand	SPNIRP
	Market cost of reactive power		

Table 8: Energy Model Regressions and Inputs summary table

3.2 Constraints Model Development

294. National Grid has procured a new piece of software to assist in the modelling of constraint costs. As the implementation of this software is currently in progress, the information in this section is more conceptual than that presented for the other energy-based models. National Grid has also developed a contingency model to guard against the risk that the procured software will not be available in time to support the operation of the scheme.
295. An addendum to this document will be issued on 13th December once the constraint modelling detail has been finalised.

3.2.1 Overview

296. The principles applied when modelling constraints are as shown in Figure 35:

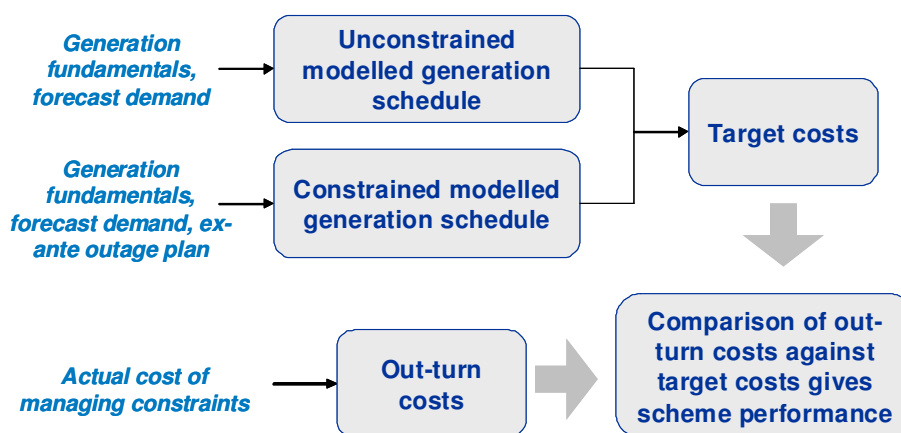

Figure 35: Overview of constraint modelling process

297. The generation fundamentals model is used to generate a schedule of plant running to meet demand. The output of this schedule will be 'unconstrained' – i.e. it will assume infinite transmission capacity. The model is then re-run with a boundary model applied, which will represent the ability of the transmission network to transfer power between pre-defined zones, the boundary capabilities of which will be modified to represent the transmission outage plan for the period covered by the scheme. Where a boundary's capability is exceeded, resulting constraints are resolved by re-scheduling plant using a representation of offer/bid prices, along with post-fault actions such as intertrips, to give an overall 'constrained' schedule of plant running to meet demand.
298. The difference in cost between the unconstrained and constrained model runs will give the modelled 'target' costs against National Grid's out-turn will be compared to determine its performance under the incentive.

3.2.2 Determining generation output

299. The use of the Plexos software model for constraints modelling is based on the application of optimisation techniques aimed at minimising total costs.
300. The first run of the model consists of a simulation of the market behaviour, whereby, assuming an efficient market, the self-despatched position of generators, in order to meet forecast demand, is defined by minimising the total operating costs (mainly fuel and start up costs), subject to a number of plant dynamics constraints such as minimum run time, minimum time between runs, run up rates, run down rates, etc.

301. The second run of the model factors in the limitations of the transmission network, with the difference between the two representing the model's assessment of the required volume and associated cost of constraint management activities.

Required input data

302. The first basic data needed is the demand forecast, which shall be met by the generators included in the study.
303. From the supply side, to achieve the initial run (the unconstrained despatch), a number of assumptions are made for each generation unit:
- Fuel prices
 - Plant efficiencies
 - Start up costs
 - Availability
 - Plant dynamic parameters

Sources of input data

304. Demand forecast, an ex-ante input, is obtained through the well established processes within National Grid. Demand is forecast at a GB level and apportioned to grid supply points based on observed and understood relationships. The demand forecast will be performed immediately prior to the creation of the ex-ante dataset for the period covering the incentive.
305. The prices actually incurred by each power station when procuring the fuel for their consumption and the associated lead-times are unknown and, as a proxy, an ex-post spot price will be used. Spot prices will be sourced from Argus.
306. Plant efficiencies are strategic information not easily obtainable through data in the public domain. The best practice in the industry to arrive at an estimation of these parameters is to assume that the efficiency for each generator's technology lies within a (publicly available) range and that the individual unit's efficiency is somehow correlated with the year it has been commissioned (the newer the generator, the more efficient it is expected to be).
307. Generic efficiency factors typically lie in the following range:
- | | |
|---|--------|
| • Coal/oil fired plant (1960s-1980s): | 38% |
| • CCGT (first generation – pre 1996): | 45-50% |
| • CCGT (second generation – 1996-2000): | 50-55% |
| • CCGT (third generation – 2000 onwards): | 54-58% |
308. From these generic efficiencies, the next step in arriving at an acceptable estimate for existing units is to simulate historic market conditions and adjust the efficiencies to a level that reflect the actual observed running regime. Parameters for future units can be estimated from similar (same technology/age) existing ones. This work is being undertaken as part of the calibration of the Plexos software by Redpoint.
309. Start up costs are relevant information to the extent that they indicate the likelihood of certain generators to two-shift (desynchronise between two runs, typically overnight). These costs depend as much on the actual incurred costs by the generator to staff the station, warm the unit up and ramp it up to the state where it's ready to synchronise as they do on the perceived risk of failing to synchronise at a critical time of the day or the implicit additional maintenance costs resulting from manufacturers' related warranty conditions in the number of starts between programmed outages. Start up costs for existing units are estimated in a similar way as that of efficiencies, i.e. through simulating historic market conditions and adjusting the costs until a reasonable match is reached. This work is being undertaken as part of the calibration of the Plexos

software by Redpoint. Information for future units will be derived from similar (same technology/age) existing ones.

310. Plant availabilities can, broadly speaking, be split into two groups: planned and unplanned. Planned outages will be based on submitted information by generators through the OC2 process (taken at a lead-time that lines up with that used for the transmission outage plan), although it is recognised that the accuracy of such data can vary, tending to decrease as lead-time increases. Unplanned outages can be estimated by the normal historical break down rates, at the moment estimated at around 10% (i.e. on average, 10% of the generation supposed to be available is on forced outage). The simulation model deals with stochastic unavailability as a standard feature.
311. Plant dynamic parameters for existing units will be obtained from historical submissions in the balancing mechanism (these are available via the Balancing Mechanism Reporting System (BMRS) or National Grid's off-line systems); for future units, they can be estimated from similar (same technology/age) existing units.

Issues with generation input data

312. From a constraint management perspective, whether or not a generator is available to run can have a significant impact on whether or not a transmission constraint exists. In the context of the proposed new approach to incentivisation, if a generator is seen as available in the Ex-Ante dataset, the generation fundamentals model will schedule it to run in accordance with the relevant parameters.
313. It is possible that the level of running modelled by fundamentals will result in a transmission constraint, once boundary transfer limits are applied and the 'unconstrained' schedule re-run. Hence the availability of the generator may trigger an allowance for constraint management, associated with its running, to be included in National Grid's target costs for constraints. National Grid's view on the potential issues this may cause is as follows:

Planned Outages

314. Whilst planned generation outages (including those associated with generator commissioning), are subject to change, National Grid considers it appropriate that they should be treated as ex-ante inputs to models, so that National Grid would be incentivised to account for planned generation outages in the co-ordinated delivery of an overall efficient outage plan.
315. The Grid Code (OC2) process for planning generation outages allow for outages to be submitted from current year to up to five years ahead. Of particular relevance to a two-year incentive scheme, by the end of engineering week 48 in any year, National Grid seeks to agree (to the extent that agreement is possible) a Final Generation Outage Programme with generators for the following two years. It is this Final Generation Outage Programme that will form the basis of the generation availability aspect of the Ex-Ante dataset.
316. Notwithstanding the extent of the agreement regarding the Final Generation Outage Programme in week 48 each year, it is the case that outages continue to be refined, moved, created or removed beyond this point. In reality, the generation outage plan for year 2 (and to a lesser extent for year 1) can vary significantly from that seen in week 48.
317. National Grid considers that the dynamic nature of generation outages could lead to the possibility of windfall profit or loss if the variability of the plan is not sufficiently represented in the Ex-Ante dataset.
318. Accordingly, National Grid proposes that incentivisation might be better served by updating planned generation outages in the Ex-Ante dataset on an annual rolling Ex-Ante basis, rather than simply fixing two years' worth of generation outages in the Ex-Ante dataset prior to the start of the scheme.

Question 14: To what extent do you consider that there exists the potential for windfall profit or loss under the scheme if a single snapshot of the generation outage plan were to be taken prior to scheme start (and used in the models for the duration of the scheme)?

Question 15: To what extent do you consider that a rolling Ex-Ante approach to modelling planned generation outages, as notified via Grid Code OC2 processes, is an appropriate mechanism to ensure the modelled outage plan remains representative (and suitable for incentivisation)? What other mechanisms could be considered?

Unplanned Outages

319. Unplanned outages are random in nature and can occur at any time; hence they would not be included in the Ex-Ante dataset agreed prior to the start of the scheme; although stochastic modelling of unplanned outages will be possible. National Grid is concerned that, even with stochastic modelling of unplanned generation outages, there exists the potential for generator faults to give the potential for windfall profit or loss, if availability is modelled when setting target costs, but that availability does not materialise in practice. To avoid this risk, National Grid proposes to treat unplanned generator availability as an Ex-Post input to models.

Question 16: To what extent do you consider that there exists the potential for windfall profit or loss under the scheme if unplanned generator availability is not considered when calculating target costs for constraint management incentivisation?

Question 17: Do you agree that treating generation faults as an Ex-input to [constraint] models is an appropriate mechanism to ensure the modelled target cost remains representative (and suitable for incentivisation)?

3.2.3 Determining transmission network capability

320. The unconstrained despatch output emulates generators' FPN submissions to National Grid, given the assumptions described above. The next step is to include transmission system constraints and re-run the optimisation algorithm, this time aiming at minimising the cost of moving from the unconstrained despatch to a feasible (constrained) one.

Required input data

321. The Interim Solution represents the transmission system as a series of boundaries. The first data required is the definition of boundaries representing the system's limited capabilities.

322. Once those boundaries have been defined, the system will be split into zones and the following assumptions can be defined:

- Zonal demand
- Zonal generation
- Boundary intact limits
- Boundary limits reduction due to outage
- Effectiveness of each generator to each boundary

Sources of input data

Boundaries to be modelled

323. The location and number of boundaries have been decided based on the most common current and most likely future bottlenecks in the system, according to the operational experience of Power System Engineers.

324. The boundaries used have been chosen to cover many of the potential issues the transmission system will face. However, consequence of using a generic boundary approach is that some issues may not be observed.
325. To ensure the longevity of the model, some boundaries have been included which are not expected to have any limit in place for the immediate future. For such boundaries, the limit used shall be set to a level which does not restrict any generation.
326. A summary of the boundaries to be modelled can be found in Appendix B.

Zonal demand and generation

327. Zonal demand has been derived based on the historical percentage of each zone's demand with relation to the total GB system demand.
328. Zonal generation is defined by the physical location of plant on the system and is easily obtained, although it does require a thorough manual process with the use of system diagrams.

Boundary limits

329. Boundary intact limits are calculated through the development of Power System Studies; limits vary through the year, as, in simplistic terms, the prevailing temperature impacts the maximum current (therefore power) an overhead line can withstand. Limits are also a function of generation and demand backgrounds and can for example change between night and day or weekday and weekend.
330. Likewise, by studying a set of key outages affecting each boundary capability, it is possible to derive a theoretical boundary limit representing the effect of a potential outage on a piece of transmission plant. These intact and outage conditions will allow the model to represent the changing boundary capabilities through time.

Generation effectiveness on overloads

331. As the complex transmission system is simplified into zones and boundaries, the critical information of how much each generator's output impacts the system capability could be lost. This is an unacceptable simplification, which is solved by the inclusion of effectiveness factors for all generators against the boundaries they are most likely to affect. Those factors are calculated through Power System Studies by modelling a reduction in each generator and assessing the effect on boundary transfers – by modelling a reduction of output on a generator by 100 MW (replacing that 100 MW geographically remote from the generator) and re-running the power system study, it is possible to determine the corresponding effect on the overload and equate this to a percentage effectiveness.
332. Based on the structural information of zones and boundaries, the next step is to define the outages durations for each boundary in the forecast period, in effect creating a profile of boundary capabilities.

Translating the outage plan into boundary limits

333. The outage durations will be taken from the Final Outage Plan in the TOGA (Transmission Outage and Generation Availability) system as agreed at the end of the calendar year prior to scheme start, adjusted to reflect changes up to either the start of the scheme or an agreed point beforehand. Note that the final outage plan covers one year only; whilst construction outages are available to some extent for subsequent years, it is likely that many outages for maintenance will not have been planned for the second year of the proposed incentive period.
334. Transmission security studies are performed to assess the following:
 - Reductions in boundary capabilities during outage periods;
 - The 'natural flow' across the boundary;
 - The most onerous contingency (circuit trip) during the outage;
 - The extent to which the boundary is overloaded following the contingency; and

- the effectiveness of generation load changes on reducing the overload
335. This information is translated into reductions in boundary capability against outage weeks, for input into the boundary model element of the Interim Solution, ready for a constrained model run to be performed.

Limitations of boundary model

336. The boundary limits are assessed in the context of the outage plan for the week being assessed using the power system analysis. Because of this, a number of limitations need to be recognised, including:
- It does not necessarily follow that an equivalent outage taking place at a different point in time would result in an equivalent reduction in boundary capability (for example due to seasonal rating effects, substation running arrangements at the time, generation background, quad booster settings); and
 - The same applies for the effectiveness of generation, which will be affected by other outages/substation running arrangements in the vicinity, as well as the prevailing generation profile.
337. It is envisaged that the enduring model will utilise actual network data, with a different set of assumptions, which will address many of these issues. However, this document sets out to describe the Interim Solution only.

Key assumptions for transmission input data

338. Generation dispatch assumptions alter the transfer which can be secured across any boundary. A complex optimisation model would be required to accurately treat the interaction between generation and transfer limits. A pragmatic view of generation output has been taken when calculating transfer limits, to flex the transmission system so that likely issues are identified while not attempting to capture all potential issues; this would imply an accuracy level which is not possible from such a generic approach.
339. The work required to derive a limit for each boundary is such that it is not possible to calculate a limit for each boundary for each week. As the limits calculated seek to reflect typical system conditions rather than a specific outage, generation and demand scenario, preparation of a limit for each individual week would again imply greater accuracy than is possible from this approach. However, a valid limit may remain in place for a number of weeks. Where it is possible to use a calculated limit across a number of weeks, this approach has been taken.
340. Outage planning processes are set out in the Grid Code and System Operator-Transmission Owner Code (STC)²². Currently, the draft outage plan for years 2 to 5 only includes construction and refurbishment outages. It is not until the final outage plan for year 1 is created at the end of each calendar year that maintenance outages are added in – maintenance work tends to be fitted around the construction and refurbishment work to allow for efficient use of outages. Hence the outage plan for the year-ahead represents the most complete outage plan to consider from an incentivisation perspective. National Grid is concerned that, by fixing outages in an Ex-Ante dataset prior to the start of a two year incentive scheme, the data for the second year will not be sufficiently representative of the actual outage plan to act as an efficient means of setting a modelled target cost, which is likely to have an impact on the suitability of those target costs for incentivisation.
341. Whilst National Grid continues to believe that planned transmission outages should be treated as an Ex-Ante input to models, it is concerned that the dynamic nature of transmission outages could lead to the possibility of windfall profit or loss if the variability of the plan is not sufficiently represented in the Ex-Ante dataset. Hence, it is of the view that incentivisation might be better served either by updating planned

²² National Grid is currently working with the industry to develop the outage management and investment planning processes set out in the STC. Further information can be found in section 5.1.2.

transmission outages on an annual rolling Ex-Ante basis, rather than simply fixing two years' worth of transmission outages prior to the start of the scheme; or by adopting a more conceptual 'boundary capacity'-based approach to determining future transmission capability. This will be considered in more detail in the constraints Addendum to these Initial Proposals.

Question 18: To what extent do you consider that there exists the potential for windfall profit or loss under the scheme if a single snapshot of the transmission outage plan were to be taken prior to scheme start (and used in the models for the duration of the scheme)?

3.2.4 Costing constraints

342. The choice of the objective function to be minimised can affect the result of this constrained optimisation. National Grid has a number of constraint management tools at its disposal, such as the BM, intertrip services, traded solutions and balancing services contracts. A modelled approach to determining a target level of constraint costs needs to be able to accommodate this range of services; and of particular importance is the derivation of prices to represent the cost of re-scheduling plant in the BM.
343. If the costs used to describe the financial impact of moving from the unconstrained position to the constrained one are based solely on market fundamentals, there is a risk that the whole dynamics of the balancing mechanism are ignored. This may lead to the wrong generators being selected by the model to resolve a constraint, which will in turn cause the volumes to be wrongly allocated to generators. Further, it is highly likely that the re-scheduling costs would be underestimated, as generators have been observed to charge a premium over costs predicted by analysis of fundamentals in their BM offer and bid price submissions. For this reason, an important input to the constraint model is the function describing the generators' BM offer and bid price submissions, given prevailing market conditions.

Deriving BM prices Ex-Ante

344. During phase 2, National Grid's approach was to develop a methodology that would derive bid and offer prices submitted in the Balancing Mechanism ex-ante, based on observing relationships between those submitted prices and the underlying costs/savings associated with Balancing Mechanism activities.
345. The results obtained through this approach were inconclusive – no robust means to describe the likely behaviour of each generator in the Balancing Mechanism was identified (whilst it was possible to identify relationships for certain BM Units, for the vast majority (some 80%) it was not possible to identify any discernable logic behind BM pricing behaviour). This may be due to the fact that different 'markets' might be in play at different times – for example there may be localised constraints markets in addition to the wider energy balancing market.

Question 19: To what extent do you think that BM price submissions can reasonably be forecast?

346. The next step is to consider whether an alternative Ex-Post approach might offer better scope for incentivisation whilst minimising the potential for windfall profit/loss.

Utilising submitted prices Ex-Post

347. In the absence of a robust means of identifying BM bid/offer prices that would be suitable for incentivising constraint management, one option is to utilise BM prices Ex-Post in the constraint modelling process. The Ex-Post BM prices would operate in conjunction with the modelled effectiveness of BM Units in alleviating boundary overloads, and the availability of other post-fault actions, such that the model can choose the most cost-effective means of resolving constraints.

348. From an incentivisation perspective, modelling the target cost for constraint management using actual prices submitted into the BM raises a number of issues:

- a) Where is the incentive to beat BM prices?
- b) What is the incentive to contract?

349. Taking these points in turn:

Beating BM price

350. It could be argued that National Grid could leave constraint management to BM timescales in the knowledge that it will be allowed to incur costs based on submitted BM prices. However it should be remembered that the price is only one element of the incentive. The target cost for constraint management will be derived based on the modelled volume and duration of the constraint in conjunction with the Ex-Post BM prices, so there will still be the need to deliver efficiencies to beat modelled target costs.

351. Further, it may be appropriate to apply a discount factor to the Ex-Post BM prices to further incentivise efficient constraint management – this is considered further with regard to contracts below.

Maintaining the incentive to contract

352. One of National Grid's key mechanisms for contracting to manage constraints is where output levels at a power station are restricted in return for a fee. Additional elements might include utilisation of intertrip capability or the application of caps/floors to BM prices. The decision to contract tends to be based on a view of the likely costs and the risk that those costs might escalate.

353. For a contract form that looks to restrict output levels in exchange for a fee, the incentive to enter into such contracts should still exist, although there is the risk that knowledge regarding system conditions gained in the course of negotiations could influence resultant BM price submissions – whilst the Ex-Post use of BM prices should mitigate National Grid's incentive exposure if further action was required in the BM, any softening of BM prices (e.g. submission of lower offer prices post-contract) could result in a lower than expected modelled target cost and convert what was seen as an efficient contracting activity at the time into an inefficient one. This could adversely affect National Grid's risk appetite when entering into such contracts.

354. For a contract form that looks to cap/floor BM prices in exchange for a fee, the incentive to enter into such contracts could be said to diminish if Ex-Post BM prices are used to model constraint costs. This is because, all other things being equal, National Grid would pay a fee to limit prices and the modelled constraint cost would only allow for recovery of costs based on the prices National Grid had contracted for – hence the option fee would be a sunk cost.

355. A potential mechanism to address these price-related issues could be through a mechanism to substitute the relevant Ex-Post BM prices with 'representative' ones. For example, the average price for each half hour for each day could be taken, for one week prior to and one week following on from the period covered by the contract. Alternatively, a contractual requirement could be placed on the counterparty to provide as a contract parameter a pseudo BM price that would apply as if contract was not in place, perhaps with an arbitration process if prices were deemed unreasonable. Such an approach might be appropriate for contracts that aim to restrict output levels; however it may be that knowledge of the method of incentivisation might have an influence on generators' negotiating stance, rendering such contracts unworkable.

Question 20: What are your views on the use of submitted BM prices Ex-Post as a means of determining target costs for constraint management?

Question 21: What are your views on the use of a 'pseudo BM price' to apply to contracted BM Units when calculating target constraint costs? To what extent do you agree that the options outlined in paragraph 355 might be suitable?

Incremental contracting efficiency

356. A further question is the extent to which National Grid should be incentivised to deliver incremental efficiencies with respect to previous contracting activity. During phase 2 of the SO Review, National grid has considered how this might be achieved.
357. Where a particular outage has been previously managed using a contract, it would be necessary to in some way map the parameters of that previous contract onto the outage. The mechanism for achieving this would be to modify the assumptions used to generate the constrained schedule to reflect the previously-agreed parameters, so that a theoretically more efficient solution to constraint management could be modelled.
358. This presents a number of difficulties:
- The original contract price might have been struck based on a package of constraint management measures (for example capped physical notifications, intertrip prices, capped offer prices); and the required volume, which would to a certain extent have driven the price level, would have been specific to the outage for which the original contract was struck. For example, a contract price may reflect the cost of constraining off wind at one extreme or a low cost intertrip at the other.
 - There is no guarantee that the duration of, or circumstances surrounding, the new outage would be the same (or similar) to the outage that generated the original contract, hence it would prove difficult to use (for example) a price target for offers, bids or commercial intertrips based on the previous contract in a meaningful way. An example of this is that the market conditions when the contract price is struck will differ over time, e.g. a price struck during short markets in the winter will significantly differ from a price struck during a long market in the summer.
359. Developing a methodology for the application of previous contract parameters to the planned outages in the ex-ante dataset would not be straightforward. A more straightforward option would be to compare out-turn actions with target constraint costs based on Ex-Post BM prices, but with a discount factor applied as discussed above.

Question 22: Do you agree that National Grid should be incentivised to beat historic constraint contracting performance?

Question 23: If yes, what in your view is the most appropriate way to achieve this in practice?

Further modelling considerations

360. Once the simulation is performed, a total cost to move the system from the 'unconstrained' position to the 'constrained' position is obtained. A methodology will be developed to describe how this total cost shall be split so that a reasonable allocation is made to each active constrained zone, including the costs for replacing sterilised headroom behind active export constraints (more information on this subject can be found in the 'Margin Volume – Constrained Margin Management' part of Section 3.

3.2.5 Constraints Incentive

361. The overall aim of constraint cost incentivisation manifests itself in a number of different ways. Constraint costs can be minimised through actions that influence the level of constraints presented by the outage plan, actions that maximise the efficient use of the

transmission system and actions that deliver efficiencies in generation running or pricing. [As with all cost categories,] For a constraint management incentive to be effective the modelled target cost needs to be reflective of the underlying drivers – the new approach aims to ensure that, as far as possible, this is the case.

Managing the outage plan

362. The Grid Code contains provisions for the co-ordinated development of outage plans to undertake construction and maintenance work on generation, transmission and distribution systems. Placing a constraint cost incentive on the SO encourages and rewards further efficiencies in this area, for example by enhancing the effectiveness of processes within existing code frameworks or by proposing changes to those frameworks.
363. For the modelled target cost to effectively incentivise constraint management, the Ex-Ante dataset needs to contain a reasonable view of the outages that will take place in the scheme.
364. Under current processes, the outage plan for year 1 should be comprehensive enough that its use in the calculation of target costs should act as a reasonable incentive. Whilst at the moment National Grid is not convinced that the outage plan for year 2 is sufficiently comprehensive for it also to be used to calculate a reasonable incentive target, it notes that optimisation does take place between National Grid as SO and National Grid as Transmission Owner for years 2 to 5; and that work is underway to develop the outage planning and investment planning processes under the STC to encourage greater co-ordination with other TOs over the same timescales. National Grid notes, however, that greater co-ordination with other TOs over years 2 to 5 is likely to be contingent on developments under RIIO-T1 that encourage greater co-operation in this area.
365. National Grid considers it important that developments in SO incentivisation and TO developments under RIIO-T1 are compatible and collectively support co-ordinated action to manage constraint costs. Whilst this should be achievable for an SO incentive scheme starting 1st April 2013 (coincident with the provisions of RIIO-T1), National Grid is of the view that, without the corresponding TO developments, it will only be possible to deliver limited optimisation of the year 2 outage plan, based on construction and refurbishment works in England & Wales; and that including year 2 outages in the Ex-Ante dataset runs the risk that modelled target costs are not representative, undermining the aims of the new approach in removing the potential for windfall profit/loss.
366. As discussed above, one potential solution to improving the accuracy of the year 2 outage plan in the Ex-Ante dataset would be to operate a rolling 12-month update process, such that when undertaking the ex-post assessment of target costs for a particular month, the outage plan used to derive the boundary limits is always that agreed as the final outage plan for year 1.

Maximising the use of the transmission system

367. The incentive on constraint management encourages National Grid to develop innovative configurations for running its substations and to develop and agree mechanisms for Users to provide actions post-fault to manage the impact of faults. In the longer-term, it encourages National Grid to consider development of (or further deployment of) innovations such as weather-related enhancements to equipment ratings; and also to work with other TOs to investigate the potential for wider roll-out of such schemes.

Delivering efficiencies in generation running/pricing

368. The incentive on constraint management encourages National Grid to develop ancillary services that facilitate as much competition as possible in the provision of constraint management services. It also encourages innovation in wider trading strategies, and the development of suitable information provision to the wider market.

3.2.6 Additional BSIS Elements

369. The following additional BSIS elements have not been considered as part of the SO Review process, so they are considered here in the same manner as previous years.

Black Start

370. National Grid has an obligation under the Grid Code to ensure that the transmission networks can be re-energised in the event of a total or partial system shutdown. Such re-energisation is known as black start. Despite the low likelihood of a total or partial system shut-down occurring, contingency arrangements must be in place to enable a timely and orderly restoration of supplies.
371. National Grid's obligation is met by contracting with generating stations to be able to re-start generation without a power in feed from the transmission system; ensuring transmission equipment can be operated in the absence of external supplies and by agreeing contingency procedures with generators and network operators. There is no obligation upon generation to provide black start services.
372. The costs for black start are dependant on contract costs which may include availability fees, capital contributions and testing fees. It is proposed that these cost elements are forecast in the normal way for the model i.e. the total forecast cost of Black Start will continue to be forecast ex-ante as now.

Transmission Losses

373. Transmission Losses on the National Electricity Transmission System are primarily a function of market unit despatch and how this impacts on the transfer of power from the north of Great Britain to the demand centres in the south east. Newly commissioned CCGTs in the South would be expected to look to achieve a high load factor in the coming BSIS year which would potentially offset some of the increased power flow that could be achieved across the Cheviot boundary following the upgrades to the conductors.
374. Transfers to continental Europe over the IFA and Britned interconnectors will increase losses due to the increased power flow to the south-east, whilst transfers from the continent to the UK will reduce them. Overall transmission losses in 2010/11 look to be at the lower end of the current 6TWh+-0.2TWh range, although this may change with higher power flows during the winter. A range of transmission losses for 2011/12 and 2012/13 could be expected to be in the range 5.9TWh +- 0.2TWh, reflecting the increased generation in the south of England since 2009/10 and current France/UK price spreads.

4. Scheme Design and Governance

4.1 Introduction

375. This section presents National Grid's proposals for the structure of a two-year incentive scheme to apply from 1st April 2011 and the governance structures and processes that would sit alongside it.
376. It also presents National Grid's thoughts on the transition from a two-year incentive to one that, for example, aligns with a price control review period, and the work that would be required to achieve such a transition.

4.2 Scheme Structure

4.2.1 High-level scheme structure

377. Ofgem's preliminary conclusion following Phase 1 of the SO Review was that the incentive scheme to apply from 1st April 2011 should be of similar format to previous schemes, but that changes to the specification of parameters would be required to allow for multi-year schemes to be set. They considered it appropriate to retain the 'bundled' nature of the scheme with risk-setting parameters (cap, floor, sharing factors).
378. National Grid agrees with the conclusions of Frontier in their Phase 1 work; and with the recommendations of Ofgem in their Phase 1 conclusions report, that a single bundled scheme remains appropriate, rather than separating costs out into different pots with potentially different sharing factors, caps and floors.
379. National Grid also agrees that the benefits of a two-year incentive would be best delivered via a single 1 x 2 year incentive, rather than by splitting the incentive into segments of one year (or some other denomination). The benefits of this approach include (amongst others) that the strength of the incentive applies equally across the duration of the scheme and should also encourage National Grid to pursue efficiencies that either take longer to develop or pay back over a longer period than would be possible with a one year scheme.

4.2.2 The target and potential need for a dead-band

380. The first thing to note about the new approach is that there will be no Ex-Ante agreed forecast of Incentivised Balancing Costs over the duration of the scheme. Instead, a monthly target will be calculated on an Ex-Post basis using both the agreed Ex-Ante and Ex-Post data in conjunction with the models to derive a modelled 'target' cost. National Grid's incentive performance will be determined by comparing actual costs with this target.
381. Historically, dead-bands existed as an attempt to manage the uncertainty associated with an agreed Ex-Ante forecast of incentivised costs. The fact that the new approach does not feature an overall Ex-Ante cost forecast removes uncontrolled risk, leading to a reduced dead-band. National Grid's current view is that there should be no dead-band applied to the proposed scheme from 1st April 2011.

4.2.3 Caps and floors

382. Historically, profit caps and loss floors served to limit National Grid's exposure to windfall profit/loss caused by movement in cost drivers beyond its control or that it could reasonably forecast. The stated aim of National Grid's proposed approach, where the relationships between cost drivers and costs have been examined and variables have been determined as either Ex-Ante or Ex-Post is to ensure that National Grid is appropriately incentivised in areas where it has control. This means that National Grid's profit/loss position should be more stable and more directly linked to the actions it takes

Section 4

Scheme Design and Governance

to deliver value. Hence a high profit cap/low loss floor could be set, to act as a greater incentive on National Grid to innovate and deliver value in exchange for a greater level of reward.

383. Further, in theory, by insulating National Grid from the influence of volatile factors beyond its control, it should be possible to remove caps and collars. However, National Grid considers that, in reality, it is likely to be necessary to limit the maximum exposure it has under a scheme; and from the industry/regulator's perspective to limit the maximum reward.
384. Whilst the proposed extension of the incentive period to two years doubles the period within which National Grid can undertake initiatives to reduce SO costs, the extent to which National Grid can take exposure to those initiatives still depends on there being sufficient time remaining within the scheme for value to be delivered.
385. Translating the current BSIS cap/collar of +/- £15m onto a two-year scheme structure would give a £30m profit cap/loss floor. Whilst National Grid considers it appropriate to place greater incentive on it to deliver efficiency in system operation by setting a profit cap of higher value than currently seen, it is also mindful of the uncertainty surrounding the operation of the proposed scheme and the increased risk presented by a symmetrical loss floor.
386. National Grid's current view is that, for a scheme with a symmetrical profit cap/loss floor, it might be appropriate to adopt a transitional approach that, whilst acting as an increased incentive on the profit side, acts to minimise risk on the loss-side until the operation of the proposed approach is better understood. It might be the case that a profit cap/loss floor of +/- £50m over two years might represent an appropriate balance between risk and reward.

4.2.4 Sharing factors

387. Sharing factors determine National Grid's cut of the profit or loss it delivers when its actual costs are compared to the incentivised cost target. As can be seen from the table in section 2.1, agreed sharing factors have tended to reduce as uncertainty surrounding the Ex-Ante agreed scheme forecast has increased. Low sharing factors mean that National Grid faces limited exposure to savings made or costs incurred through its actions; hence the incentive to deliver value could be considered weaker and the scope for reward may not be commensurate with the cost of delivering change.
388. Conversely, high sharing factors mean that National Grid faces significant exposure to savings made or costs incurred through its actions; hence the incentive to deliver value could be said to be stronger and the scope for reward may be such as to encourage significant value creation. National Grid's proposed approach aims to minimise National Grid's exposure to factors beyond its control, hence it should be possible to increase its exposure and adopt a more equal share of the risk/reward.
389. Historically, there have been occasions where sharing factors have been asymmetrical around a fixed cost target, reflecting a reduced downside exposure for National Grid compared with potential upside rewards. Such an approach was taken to manage the uncertainties associated with the introduction of NETA in 2001 and BETTA in 2005.
390. Whilst such an approach is a useful means of dealing with the type of uncertainty around absolute SO cost levels introduced by changes in trading arrangements, the new approach to incentivisation aims to perform the same role – by insulating National Grid from volatility in factors beyond its control, it should not be necessary to have asymmetric sharing factors.
391. National Grid considers that, for this new approach, National Grid should look to share its exposure to profit and loss under the scheme equitably with consumers, i.e. sharing factors should generally equal +/- 50%.
392. National Grid notes, however, the uncertainty associated with the introduction of a significant step-change in incentivisation such as that of the proposed new approach.

Section 4

Scheme Design and Governance

Further, there is also the linkage between BSIS sharing factors and those used for its incentive on internal SO costs, which is set through the Transmission Price Control Review (TPCR) process. This is considered further below.

4.2.5 Impact on internal incentive scheme

393. As well as an incentive to manage external SO costs (BSIS), National Grid's controllable SO (OPEX) costs are incentivised on a sliding scale basis around a target (which was set for 5 years at TPCR4) but with sharing factors which align with BSIS (currently 15% on both upside and downside).
394. The rationale for sharing factor alignment is to provide National Grid with the same exposure to internal and external costs and therefore promote efficient arbitrage between its internal OPEX costs and external balancing costs. In practice, this means that if National Grid can reduce balancing costs and therefore derive benefits through BSIS by increasing OPEX (e.g. employing more staff) then it has an incentive to do this, at least on an annual basis (upon which BSIS is presently set). Extending the duration of BSIS to two years will increase the scope to undertake such activities.
395. It is also worth noting that incentivisation of activities that are deemed 'TO' operates differently to those deemed 'SO'. A target OPEX allowance was set at TPCR4 but (effectively) with 100% sharing factors, as National Grid is wholly exposed to OPEX increases or decreases around this allowance. This provides a strong incentive for the TO to reduce OPEX costs, whereas there are circumstances when incurring additional TO OPEX is likely to have benefits for reducing SO balancing costs (e.g. by instigating weekend/24 hour working to shorten outage durations). This issue is explored further in section 5.1.1.
396. National Grid considers that the new approach will allow it National Grid to face a greater exposure to profit/loss through increased sharing factors and that this will therefore have a consequential impact on its internal SO incentive scheme. This impact could be positive or negative. To ensure consistent treatment, National Grid considers that the scope of the internal SO incentive should be reviewed as part of the RIIO-T1 process, in light of changes to the external incentive to implement the new approach, to ensure that it remains possible to effectively trade-off decisions between the two schemes.
397. Discussions are underway within National Grid to keep its price control review staff up to date with BSIS developments and to ensure that developments to the internal SO incentive scheme as part of RIIO-T1 recognise the principles being adopted to manage the incidence of windfall gains and losses within BSIS.
398. In lieu of a review of the internal SO incentive scheme, and to acknowledge uncertainty regarding how the new approach to incentivising external SO costs will work in practice, National Grid considers it appropriate that a 'soft landing' approach be taken to setting the sharing factors for BSIS covering the period April 2011 – March 2013, at which point the provisions of RIIO-T1 will take effect.
399. National Grid considers it important to ensure that the transition to the new approach to incentivisation of external SO costs, with its aim to reduce the possibility of windfall gains/losses, does not result in the transfer of potential for windfall gains/losses to the internal SO incentive in its current guise, by way of increased sharing factors.
400. National Grid is of the view that, until experience of operating its new approach is gained and the internal SO incentive is reviewed under RIIO-T1, it might be appropriate to adopt a transitional approach to setting BSIS sharing factors (for example by choosing +/- 25%) that reflects the less volatile nature of the proposed approach whilst at the same time protecting the internal scheme until such time as a full review can be completed.
401. With a £50m profit cap/loss floor, 25% sharing factors equate to an incentivised cost range of +/- £200m. This is a wide incentivised range - given that one of the aims of the new approach is to remove the potential for windfall gains/losses, it could be argued

Section 4 Scheme Design and Governance

that such caps and floors would be unlikely to come into play over a two-year scheme, however a wide incentivised range would mean there would be a continued strength of incentive to deliver value through the scheme, rather than there being a risk of hitting the cap/floor early on in the scheme.

4.3 Proposed scheme profile

402. Figure 36 shows National Grid's proposed scheme profile for 1st April 2011 to 31st March 2013, compared to that of the 1st April 2010 – 31st March 2011 scheme:

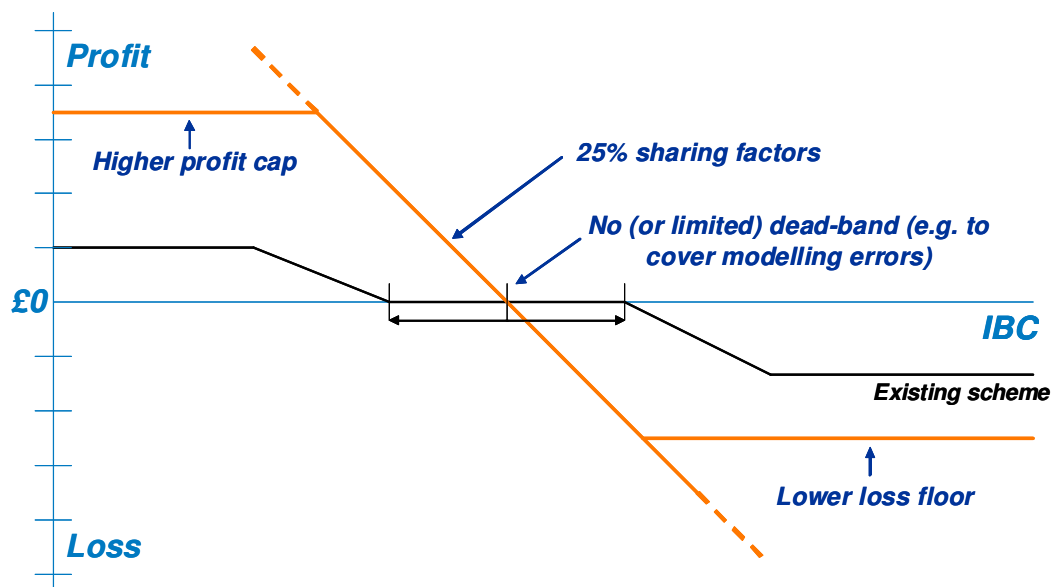

Figure 36: Proposed scheme structure

403. As mentioned in section 4.2.2, the scheme will be defined by reference to a variable, rather than fixed, incentivised cost target. A dead-band of +/- [x] will apply, before profit and loss sharing factors of +/- 25% spread out to a profit cap and loss floor of +/- £50m.

Question 24: To what extent do you agree with National Grid's views on the need for a cost 'dead-band' under the proposed approach to incentivisation?

Question 25: To what extent do you agree with National Grid's views on the magnitude of the profit cap and loss floor under the proposed approach to incentivisation?

Question 26: To what extent do you agree with National Grid's views on the magnitude of sharing factors under the proposed approach to incentivisation? What do you consider to be an appropriate level of sharing factor?

4.4 Governance

4.4.1 Agreement prior to incentive scheme start

404. A key principle of the new approach is that National Grid should be insulated from volatility in cost drivers beyond its control. In practice this means that cost drivers that are volatile or unpredictable are not forecast as part of the incentive scheme setting process; instead they are accounted for post-event via the use of out-turn data.
405. National Grid considers that, for its approach to be successful, it is necessary for National Grid to agree with Ofgem the models that will be used, the treatment of model inputs as either Ex-Ante or Ex-Post; and the formulation of Ex-Ante and Ex-Post

Section 4

Scheme Design and Governance

datasets, so that the models can be run to determine an 'efficient' level of system operation costs against which National Grid can be incentivised to deliver value.

Agreeing criteria for treatment of data

406. National Grid considers that a balance needs to be struck between insulating it from volatility and risk associated with drivers it cannot control or be reasonably expected to forecast, and the need to ensure appropriate incentives are placed on National Grid to deliver value. Therefore, National Grid considers that the derivation of an appropriate split between Ex-Ante and Ex-Post treatment of drivers is also key to the success of the new approach.
407. National Grid considers it essential that the criteria used to assess whether drivers should be modelled Ex-Ante or Ex-Post should be publicly available and established subject to a formal governance process. National Grid's proposed treatment of cost drivers is outlined in section 2.

Agreeing models and associated data

408. National Grid has procured software (Plexos) that is capable of modelling generation running using fundamental economic principles and applying that generation running to both unconstrained and constrained network representations, so that a modelled level of constraint costs can be determined. Models to determine other costs, (such as those required to assess margin, frequency response, etc), have been developed in-house. The suitability of the models and the associated modelling approach will be assessed by Ofgem in phase 3 of the SO Review. Where recommendations for further work regarding the models or modelling approach arise, either from phase 3 of the SO Review or through other stakeholders, National Grid expects to act upon such recommendations with a view to delivering revisions that result in models and a modelling approach that are acceptable and suitable to support Ofgem's Final Proposals for a two-year incentive scheme starting on 1st April 2011.
409. For those cost drivers identified as being suitable for Ex-Ante treatment, the formulation of relevant datasets will need to be agreed. These datasets will, to all intents and purposes, become 'fixed' once they have been agreed between National Grid and Ofgem prior to the start of the incentive scheme.
410. For those cost drivers identified as requiring Ex-Post treatment, data sources and appropriate timescales and resolutions will need to be determined in a transparent and non-subjective manner.
411. For all models, the datasets containing the Ex-Ante and Ex-Post data are described at a high level in section 3 (although clearly a greater level of detail will be required in the formal scheme agreement). The models and datasets will set the benchmark against which National Grid's performance under the scheme is assessed, therefore it is important that they reflect, as far as reasonably possible, a realistic 'efficient' level of SO costs for National Grid to try and better.

Form of agreement

412. National Grid considers it appropriate that this information be set out in a methodology statement pursuant to its transmission licence. This would allow for a transparent approach to agreeing the treatment of model inputs to be taken and would allow the detail to be reviewed and updated using an established mechanism.
413. However, National Grid considers the nature of its agreement with Ofgem regarding specific model parameters and the actual data used should not be visible to the wider industry, as given the right models it may allow interested parties to actively determine National Grid's incentivised target costs and attempt to influence its performance under the incentive scheme. Instead, National Grid considers that such agreement should be made bilaterally and referenced in the licence condition governing the establishment and operation of the system operator incentive.

Section 4 Scheme Design and Governance

Question 27: Do you agree that National Grid should be concerned about the potential for parties to influence its performance under the incentive scheme by using information that it makes available to the wider industry?

414. National Grid's view on the form of this agreement is summarised in Figure 37:

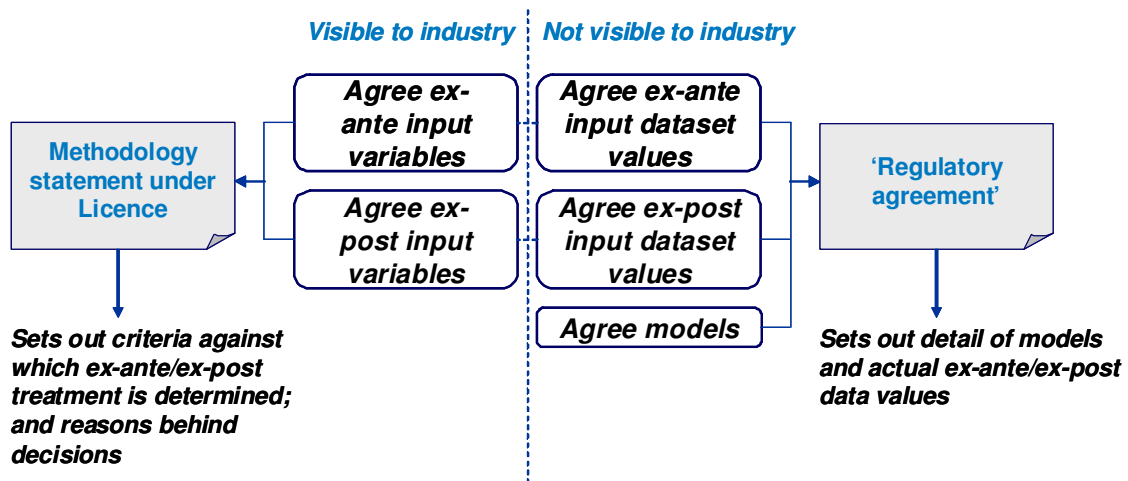

Figure 37: Overview of proposed governance structure

415. National Grid proposes to formulate a methodology statement describing the criteria against which National Grid will assess whether model inputs should be treated on an Ex-Ante or Ex-Post basis. It is proposed that this methodology would be established and maintained under provisions set out in the SO Incentive licence condition and would be developed and consulted on in parallel to Ofgem's Final Proposals process such that it can be implemented once the licence condition takes effect. National Grid considers that, to allow for learning points to be drawn from the scheme to which the methodology relates, it should lapse at the end of the scheme and be reviewed and re-created with each new scheme.
416. National Grid proposes that the SO Incentive licence condition also references the agreement between National Grid and Ofgem regarding the model parameters and input data to be used to determine the target incentivised costs.
417. Finally, it is proposed that, as now, the SO Incentive licence condition contains the parameters describing the incentive scheme profile as set out in section 4.3. These provisions will be similar to those currently governing the operation of 2010/11 BSIS, with the exception that the new approach removes the need for the ongoing Net Imbalance Adjustment (NIA) and other ad-hoc adjusters, such as those established for the 2010/11 BSIS to deal with uncertainty surrounding the additional level of generation connecting in Scotland and flows across the Interconnexion France-Angletère (IFA).
418. Note that, whilst the removal of NIA also removes the need for the net imbalance reference price (SPNIRP), certain of National Grid's models use SPNIRP as an input; therefore its definition will continue to be captured in National Grid's model documentation.

Question 28: Do you agree that the creation of an open, transparent statement describing National Grid's methodology for determining whether model inputs should be treated on an Ex-Ante or Ex-Post basis is appropriate?

Section 4 Scheme Design and Governance

Forecast of Incentivised Balancing Costs and BSUoS charges

419. The new approach operates on the basis that models and datasets, rather than a forecast of incentivised costs, are what will be agreed for the purposes of setting the incentive scheme. However a forecast of BSIS performance will be required from an accounting perspective and for the purposes of regulatory reporting.
420. Further, National Grid anticipates that industry participants would want to see an indication of the potential magnitude of incentivised costs broken down by component. National Grid proposes to continue to report its performance against the incentive scheme through its Monthly Balancing Services Summary (MBSS) report as now.
421. National Grid proposes to continue to provide a BSUoS charge forecast as part of its routine system operations cost update at its regular Operational Forum industry meetings. Further information regarding the impact on BSUoS of moving to a two-year incentive duration follows shortly.

Question 29: What are your expectations of National Grid when it comes to the production of an Incentivised Balancing Cost/BSUoS charge forecast?

Question 30: What are your views on the timing of such forecasts? For example, do you have processes that will be impacted by the timing of publication of an IBC/BSUoS forecast?

4.4.2 During the incentive scheme

422. During the incentive scheme it will be necessary to determine, on a routine basis, the efficient level of costs against which National Grid's performance is to be compared. In accordance with current regulatory and financial reporting timescales, National Grid proposes that this continues to be on a monthly basis.

Assessing National Grid's incentive scheme performance

The general process for assessing National Grid's performance under the incentive scheme will be as shown in

423. Figure 38:

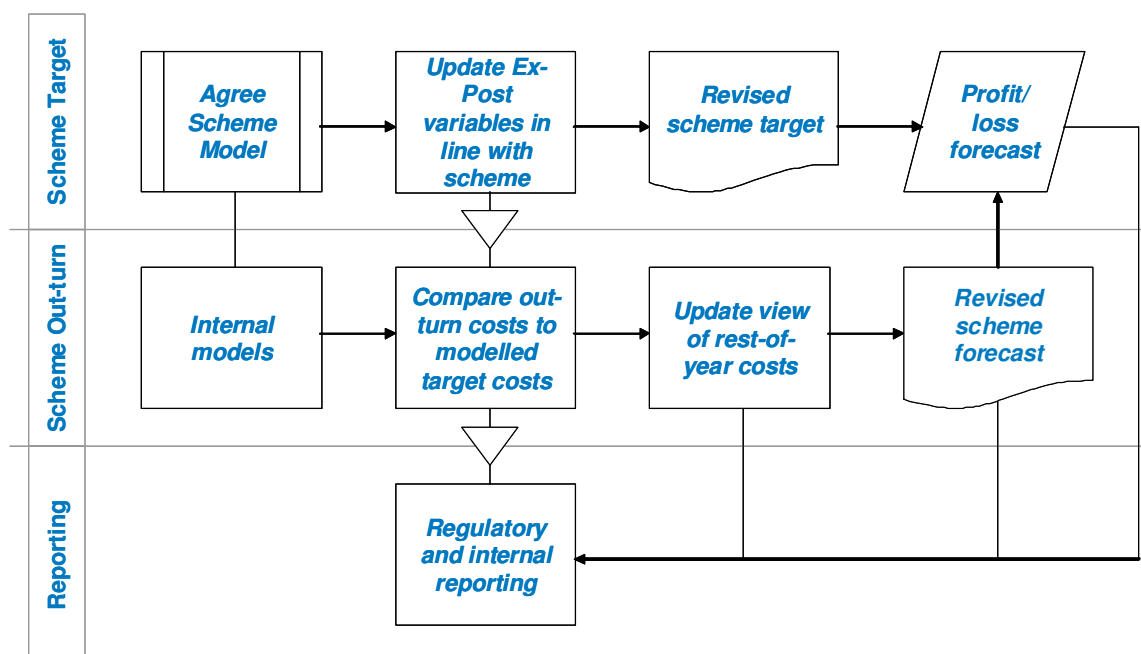

Figure 38: Process for assessing National Grid's BSIS performance

Section 4

Scheme Design and Governance

424. National Grid's modelling will be based on both scheme target and scheme out-turn datasets, as follows:
- **Scheme target data:** The agreed scheme Ex-Ante dataset (which will be fixed at the start of the scheme) will be combined with an Ex-Post dataset that features both out-turn data and an updated view, in line with that agreed in the scheme design, of how those Ex-Post inputs might out-turn at scheme end to provide (a) an updated scheme target up to and including the previous month and (b) a forecast scheme target at scheme-end; and
 - **Scheme out-turn data:** National Grid will update and maintain a separate Ex-Ante dataset to reflect National Grid's best view of where costs will out-turn at scheme end, and will combine this on a monthly basis with an Ex-Post dataset that features both out-turn data and a best view of how those Ex-Post inputs might out-turn at scheme end, to provide an updated view of out-turn costs for the whole scheme duration.
425. This modelling approach will allow National Grid to evaluate monthly Ex-Post scheme targets, compare outturn costs to those targets to determine its performance under the scheme, and present a forecast view of target and out-turn costs (and hence forecast scheme performance) at scheme end.
426. Additionally, it will allow National Grid and Ofgem to assess the performance of the models on an ongoing basis to determine whether they are providing target costs that are appropriate – this is considered further below.

Within-scheme adjustments

427. Historically, National Grid's SO incentive schemes have featured provisions for 'Income Adjusting Events' (IAEs) which, in addition to accommodating force majeure events as defined in the Balancing and Settlement Code (BSC) and Connection and Use of System Code (CUSC), allow for National Grid and other Parties (as defined in the BSC) to propose adjustments to the Incentivised Balancing Costs to cater for unforeseen events which have increased or decreased its value by greater than £2m.
428. National Grid's proposed approach is intended to remove much of the uncertainty associated with an ex-ante forecast of IBC. However, there will still be circumstances under which an adjustment to the process of managing the scheme is required.
429. Under normal circumstances it should not be necessary to make any adjustments to the models or data used to determine the cost targets against National Grid will be incentivised. However, National Grid has identified the following specific circumstances where it may be appropriate to make within-scheme changes to the models and/or data that comprise the incentive scheme:
- a) **to allow for clear errors in formulae or data to be corrected:** National Grid considers it appropriate to have the ability to agree limited revisions to the models/modelling approach where errors are identified with formulae or model input data;
 - b) **to allow for changes brought about by shifts in regulation or step-changes in policy:** Such changes have the potential to materially impact National Grid's performance under the incentive scheme and, to the extent that it is not possible to forecast their occurrence when scheme parameters are agreed, National Grid considers it appropriate to have the ability to make any necessary revisions to the scheme to mitigate their effect; and
 - c) **to deal with Security Periods²³ and Force Majeure events under the Balancing and Settlement Code (BSC) and Connection and Use of System Code (CUSC):**

²³ As defined in National Grid's transmission licence as "a period commencing on the date on which any direction issued by the Secretary of State under section 34(4) of the Act enters effect and terminating on the date (being not earlier than the date such direction, as varied, is revoked or expires) as the Authority, after consultation with such persons (including, without limitation, licence holders liable to be principally affected) as it shall consider appropriate, may with the consent of the Secretary of State by notice to all licence holders determine after having regard to the views of such persons."

Section 4

Scheme Design and Governance

National Grid's transmission licence currently contains provisions for managing the impact of security periods and force majeure on its external cost incentive; and it is proposed that these provisions remain for the scheme starting 1st April 2011.

430. Such within-scheme changes would be managed via a 'scheme adjusting event' concept similar to (and in replacement of) the current IAE provisions. National Grid envisages that, like the current IAE provisions, a scheme adjusting event could be raised by any of National Grid, Ofgem or other BSC parties.

Other 'known unknowns'

431. There are a number of other events that are expected to take place during the course of the scheme that are likely to have an impact on the proposed incentive scheme from 1st April 2011, but that are difficult to model or quantify to any reasonable extent at this time:

Olympic costs

432. During the month of the London Olympic Games, measures will be taken to secure supplies in a time of increased risks to the country's (and the electricity supply industry's) reputation. Whilst at the moment the full detail of the proposed measures is still under development, early indications suggest that frequency response and reserve requirements will need to be increased, in order to allow the system to withstand high impact, low probability events such as the consecutive loss of two large generation units (similar to that which occurred on 27th May 2008).

Britned ramp management

433. Interconnectors have the technical capability to change flows very rapidly and, in order to maintain system security during times of significant change in flows in short timescales; National Grid uses ramp management services on the relevant interconnector. Agreement has not yet been reached for the introduction of a ramp management service on Britned, so alternative services will have to be used to cope with rapid changes in flows, in particular through Fast Reserve units.

Largest infeed loss

434. Following from the proposal of changes to the NETSQSS to increase both the frequent and infrequent largest infeed loss (GSR007), Ofgem is undertaking an impact assessment of the proposal. The proposed starting date for this change is "as soon as a unit of more than 1320 MW connects to the system". Whilst it is highly unlikely that such event happens in the next 2 years, should the conditions for the introduction of this NETSQSS modification change, additional Frequency Response and Reserve will be required to be held.

Question 31: Do you agree with the concept of (and need for) a Scheme Adjusting Event? If so, what sort of events do you consider it appropriate to adjust for?

Question 32: To what extent do you consider that the scheme needs to be able to cope with the 'known unknowns' listed in section 4.4.2? How might the impact of these events be managed?

4.4.3 Managing the transition to a two-year incentive

435. National Grid's approach to managing the transition to a two-year incentive is to minimise its impact, where possible, on existing processes

Impact on BSUoS processes

436. National Grid's BSUoS team have considered the impact that the new approach to incentivisation will have on routine BSUoS processes.

Section 4

Scheme Design and Governance

437. Using a recalculated scheme target, as and when required, would mean that, rather than using fixed points from the target to describe any cap, floor or dead-band, it would be necessary to calculate them relative to a variable target. The value of the target would be determined by National Grid and provided to the BSUoS calculation system. The system would then use the target to determine the absolute values for the cap, floor, sharing factors and dead-band, in order to calculate the incentive for inclusion into BSUoS Charges.
438. Calculating the incentive performance for the two year period using a rolling average for the two year period would generally follow the same method as is used now. The only difference is the varying target that essentially allows the graph to be redrawn. Removing the NIA concept would present no problems and would actually improve content of Interim Initial settlement run calculations - currently NIA forces these to zero due to information availability.

Implementation for BSUoS Charges

439. National Grid's BSUoS team note that, to accommodate the shift from a fixed incentive target to a variable one, a minimum of three months from the date of Ofgem's decision is likely to be required for implementation. There may also need to be reciprocal changes on User systems, which might add to these timescales, depending on the extent to which they can be undertaken in parallel..

Question 33: Do you consider that your systems will be impacted by the proposed change to scheme structure outlined in these Initial Proposals? If so, what information will you require (and in what timescales) in order to accommodate the change?

Impact on Finance processes

440. National Grid's Finance department have considered the implications of a multi-year incentive on financial reporting, with particular emphasis on the reporting of profit or loss under the scheme.
441. For the current BSIS, they take a monthly re-forecast that represents the latest business view on the final outcome of the incentive. Actual profits are booked on a pro rata basis so that the run rate is kept consistent with the latest forecast.
442. For the proposed two year BSIS, their view is that accounting standards will enable them to report a prudent expectation of performance under a multi-year incentive scheme on an annual basis. Hence they do not see a move to multi-year incentives presenting any issues from a finance perspective.

5. Further Work

5.1 Transition to a Longer Term Scheme

443. Having gone through the process of developing a two-year incentive structure, National Grid has identified a number of issues which, should the incentive duration extend beyond two years, would need to be revisited or treated differently.

5.1.1 SO/TO sharing factor alignment

444. On 18th September 2009, National Grid published an informal consultation²⁴ to the industry, entitled Potential Enhanced Electricity Transmission Owner (TO) Incentives. The purpose of the document was to consult the industry about whether there were benefits in enhancing a number of SO/TO interface issues, one of which was the alignment of incentive sharing factors between National Grid as SO and National Grid as Transmission Owner.
445. Incentivisation of activities that are deemed 'TO' operates differently to those deemed 'SO'. A target allowance was set at TPCR4 but (effectively) with 100% sharing factors, as National Grid is wholly exposed to OPEX increases or decreases around this allowance. This provides a strong incentive to reduce TO OPEX costs.
446. There are circumstances when incurring additional TO OPEX is likely to have benefits for reducing balancing costs. At one end of the spectrum it might be to instigate weekend or 24hr working to enable a circuit to be returned to service earlier than planned in response to a change in an interacting generation outage. At the other, it may be the establishment and deployment of technologies and techniques such as temporary bypasses. The presence of different sharing factors and hence "incentive rates" between TO OPEX costs and SO OPEX / balancing costs therefore potentially has a distortionary effect. This may act to stifle opportunities to reduce constraint costs through incurring additional costs which are currently deemed and accounted for as TO OPEX.
447. For example, under the current SO incentive scheme with 15% sharing factors, if National Grid as TO (with 100% sharing factors) were to spend £1m on OPEX, which reduced constraint costs by £5m, National Grid as a whole would see a £1m TO cost but only a £0.75m benefit under the SO incentive, giving an overall loss of £0.15m.
448. The September consultation proposed short-term measures to alleviate this potential distortion, by allowing specific 'TO OPEX' additional costs which are incurred, in certain circumstances, to be deemed 'SO controllable OPEX costs' and therefore pass through the internal SO incentive. It asked the industry whether short-term measures should be taken ahead of TRCR5 to address the current incentive distortions.
449. There was broad support for addressing, in the short term, those differences between the SO and TO incentives that could give rise to perverse incentives (and, by extension, addressing the structural issues more comprehensively as part of RIIO-T1). Respondents were of the view that aligning the incentive structures should promote a more optimal approach to managing constraints across both SO and TO activities.
450. To this end, National Grid is actively involved in RIIO-T1 discussions regarding potential TO output measures and incentive mechanisms associated with constraint costs and anticipatory investment. Discussions are underway within National Grid to keep its TPCR staff up to date with BSIS proposals and to ensure that developments regarding potential TO output measures and incentive mechanisms as part of RIIO-T1 recognise the principles being adopted to manage the incidence of windfall gains and losses within BSIS.

²⁴ <http://www.nationalgrid.com/NR/rdonlyres/FB4A9925-15AB-462A-B516-33543A44B460/37082/PotentialEnhancedElectricityTransmissionOwnerIncen.pdf>

5.1.2 SO / TO Interactions

451. National Grid is currently undertaking work in parallel to the SO incentive review to look at ways in which increased collaboration between the SO and TOs can improve outage planning. More specifically, meetings between National Grid and the Scottish TOs²⁵ (STOs) commenced earlier this year to discuss potential developments to the SO-TO Code (STC) in terms of investment planning (Long Term Planning) and outage planning (Medium Term Planning) processes, and to facilitate a more economic, coordinated and efficient outage planning process.
452. From these discussions, the following developments were proposed by National Grid in July 2010 which are discussed in more detail below:
- Regular bi-lateral (and tri-lateral where schemes affect both STOs) review meetings between National Grid and the STOs for the long Term Planning (2-5 years)
 - A long-term to medium term outage plan handover to include the STOs taking the opportunity to review outage plans and for National Grid to undertake further economic analysis if appropriate
 - Medium Term Planning (0-2years) - Development of 2-year outage planning process, minimising construction and maintenance outages on derogated boundaries
 - Regular interface and dialogue between parties to improve the optimisation of outage placement

Long Term Planning

453. At the meetings, it was proposed that greater collaboration between the SO and STOs be encouraged, in accordance with current STC Procedures (STCPs), to ensure that, for example, early and periodic economic assessment is made of STO capital schemes by National Grid. This should serve to raise STO awareness as to the impact on forecast constraint costs of proposed methods of working and how costs could be affected if those methods were to change.
454. National Grid believed that there would also be benefit in having a forum with the STOs to discuss and review both new and in-progress Planning Requests²⁶. Mitigating actions required to manage derogated boundaries may require Planning Requests to be taken forward by the relevant STO (e.g. commercial intertrips). It was proposed that either current bilateral meetings or new tri-partite meetings could be the correct forum for these exchanges to take place.
455. In addition, it was proposed that there be more frequent exchanges of new and revised (in relation to scope of works, programme and outage requirements) Project Listing Documents (PLDs) and Transmission Owner Reinforcement Instructions (TORIs). This would also enable National Grid to assist with other STO developments to ensure efficient co-ordination of GB outages. Early visibility of amendments to outages would allow for more optimal outage and works planning.
456. These long term planning proposals are currently being implemented via an amendment to STCP16-1 under amendment proposal PA061²⁷. Agreement to amend this procedure will be sought at a STC Committee meeting in October as these are not subject to the same governance process as the STC itself and require approval from National Grid and the STOs only.

²⁵ Scottish Transmission Owners comprise Scottish Power Transmission Limited (SPTL) and Scottish Hydro Electricity Transmission Limited (SHETL).

²⁶ Planning Requests are issued to the relevant STO where the SO requires some works to be carried out on that STOs network e.g. installation of intertripping equipment

²⁷ Details of the proposal can be found at: <http://www.nationalgrid.com/NR/rdonlyres/FA49511F-20D0-404F-AF83-CFF512E8B7D7/42797/PA061STCP161LongTermOutagePlanningAmendmentProposal.pdf>

Medium Term Planning

457. Currently, a STO has to submit Outage Proposals in Week 49 for the following financial year as set out in Section C, Part 2 of the STC. Responses to National Grid's Consultation in Autumn 2009 on potential TO incentives and enhanced SO/TO working²⁸ showed broad support for extending the current duration of the Final Outage Plan (FOP) from one to two years. This would provide greater scope for outage optimisation and co-ordination between the SO, TOs and generators, whilst also allowing change costs to be funded over this extended period via the Outage Change Allowance (OCA) mechanism²⁹.
458. The submission of 'additional years' outages would allow National Grid as SO to build outage plans with all known outages further ahead of real time which in turn means that the SO is better able to optimise the outage plan. It also provides an earlier opportunity to review the outages required to ascertain whether there may be value in working in a different way or re-designing works to reduce outage durations to reduce constraint costs.
459. Two proposals are therefore currently being pursued to facilitate the implementation of two year FOP timescales. The first, which is presently going through Working Group stage is STC Modification Proposal CA039³⁰. This was proposed in July 2010 and looks to amend the STC (Section C, Part 2) so that each TO must submit to National Grid the final version of its Outage Proposal for the following financial year and the subsequent year. This STC modification proposal is due to be published for consultation within the next few weeks following final working group discussions.
460. The second associated proposal which relates to the implementation of a two year FOP is an amendment to STCP11-3³¹. This amendment proposal looks to extend the period over which the SO can reimburse a STO the cost associated with changing an outage via the OCA mechanism. Costs incurred by a STO for certain Transmission Owner outage changes requested by National Grid for the current Plan Year or in the Outage Plan issued in Week 49 for the subsequent Plan Year will therefore be extended for Year 2.
461. A further amendment proposal has been raised in relation to medium term planning which looks to encourage more regular dialogue and information exchange between the STC Parties. The proposal to amend STCP11-132 seeks to add a handover meeting between National Grid and the STOs in to the transitional period between the long term and medium term outage planning phases. As with the aforementioned STCP amendment proposals, a final decision will be made as to whether it will be implemented at the next STC Committee Meeting.
462. In essence the above developments look to increase communication between the STOs and National Grid at various stages of the process to facilitate a more co-ordinated approach to outage planning. An extended outage planning timeframe of two years coupled with more information from National Grid on how changes to STO schemes and outages could affect constraints should serve to raise awareness, and therefore reduce constraint costs.

²⁸ The document can be found at:

<http://www.nationalgrid.com/NR/rdonlyres/FB4A9925-15AB-462A-B516-33543A44B460/37082/PotentialEnhancedElectricityTransmissionOwnerIncen.pdf>

²⁹ An allowance available to the SO to make payments to the relevant STO should changes be requested to the FOP.

³⁰ More information can be found at:

<http://www.nationalgrid.com/uk/Electricity/Codes/sotocode/WorkingGroups/CA039/>

³¹ The amendment proposal document can be found at:

<http://www.nationalgrid.com/NR/rdonlyres/C4699A03-1652-41ED-A640-7D7EC7912D92/42796/PA060STCP113OutageCostingAmendmentProposal.pdf>

³² The amendment proposal document can be found at:

http://www.nationalgrid.com/NR/rdonlyres/7811D549-4684-491C-8E35-53DA9AE9C648/42795/PA059STCP111OutagePlanningAmendmentProposal_2_.pdf

5.1.3 Grid Code process for submitting Generation Outages

463. The previous section examined ways in which processes are to be improved to achieve greater efficiencies in outage planning between the SO and TOs to ultimately minimise constraint costs. However, transmission outages are only one piece of the outage planning puzzle which also requires alignment, as far as possible, with generation outages to enable the GB outage plan to be fully optimised.
464. Generators are obliged to comply with the process set out in OC2 when scheduling outages to their generating units with generators able to submit amendments to these outages at various intervals (the last amendment allowable under OC2 is by 11:00 each business day for day 2 ahead to day 14 ahead). Whilst it is recognised that there are many valid reasons for outage details to be changed, (e.g. breakdowns, delay in delivery of spares and contractor availability) such changes can have a significant impact upon constraint volumes and therefore the cost of managing those constraints.
465. To submit outage details in accordance with OC2, generators are required to use National Grid's TOGA³³ system which includes both the duration and MW available for the period in question. At present a TOGA user can see its own generation availability and the zonal generation availability for any zone. However, following implementation of Balancing and Settlement Code (BSC) modification proposal P243³⁴, generation availability of individual BMUs will be available on the Balancing Mechanism reporting System (BMRS). This will allow more strategic decisions on generation to be made.
466. Aside from P243, National Grid is looking at further ways in which the generator outage planning process can be improved. The objective of these improvements is that generators are ultimately more aware of the impact that changes to generator outages may have to the wider system and therefore to the cost of system operation, particularly with regard to constraints. This work has been initiated within National Grid and will be discussed with the industry in due course.

5.1.4 Constraint Information and Transparency

467. Further work with regard to constraint management and information transparency has already commenced within the Commercial Balancing Services Group³⁵ (CBSG) forum. Discussion within this group to date has included the provision of further generator availability information, more granular information on constraint management contracts and *Ex-Post* constraint cost allocation. A presentation summarising the proposed areas for further discussion with regard to constraint information transparency can be accessed on the CBSG web page³⁶. This work will continue over the coming months via the CBSG forum.

³³ Transmission Outage Generator Availability (TOGA) is a web-based IT system that facilitates the submission and exchange of Grid Code generator outage and availability data with National Grid

³⁴ More information can be found at:

http://www.elexon.co.uk/changeimplementation/findachange/modproposal_details.aspx?propid=268

³⁵ The commercial Balancing Services Group is an industry forum for the discussion of Balancing Services which are not governed by industry Codes. More information can be found at:

<http://www.nationalgrid.com/uk/Electricity/Balancing/CommercialBalancingServicesGroup/>

³⁶ This presentation can be found at: http://www.nationalgrid.com/NR/rdonlyres/AD47C884-C21B-4672-9439-89CD839F5A47/40987/CBSG_info_provision_constraints.pdf

Section 6

List of Questions

6. Further Information

468. Information regarding the types of Balancing Services procured by National grid can be found in a dedicated area of our website:

<http://www.nationalgrid.com/uk/Electricity/Balancing/services/>

469. National Grid makes regular presentations on all aspects of system operation at its regular Operational Forum meetings. More information can be found here, via the menu on the left of the screen:

<http://www.nationalgrid.com/uk/Electricity/Balancing/operationalforum/>

470. Information regarding National Grid's view on future requirements for Balancing Services can be found here:

<http://www.nationalgrid.com/uk/Electricity/Balancing/services/FutureRequirements/>

7. Contact Us

471. If you would like to discuss any aspect of SO Incentives, please contact us via the contact details below:

On the web:

The dedicated web pages for this process are available at the following addresses:

Electricity SO Incentives: <http://www.nationalgrid.com/uk/Electricity/>

Gas SO Incentives: <http://www.nationalgrid.com/uk/gas/>

Contact us:

Gas

Juliana Urdal

Tel: 01926 656195

juliana.urdal@uk.ngrid.com

Electricity

Ian Pashley

Tel: 01926 653446

ian.pashley@uk.ngrid.com

General enquiries:

SOincentives@uk.ngrid.com

472. To register your interest in receiving future communications on this consultation process please email soincentives@uk.ngrid.com.