

# The British Electricity Trading and Transmission Arrangements (BETTA)

Connection Agreements Transition Seminar

9th November 2004, London

11th November 2004, Glasgow

# Agenda

- Introduction and welcome
- GB contractual/regulatory framework
- Run off of transmission agreements and changes to existing distribution agreements
- Transition to GB Connection/Use of System Agreements
- Allocation of access to GB Transmission System
- GB charging arrangements
- Question and answer session

# What is BETTA?

- Single GB Market for Electricity Transmission and Trading
  - Three Transmission Licensees (TOs)
  - One GB System Operator – NGC

# GBSO/TO roles



## Transmission Licensee

- Own build and maintain assets

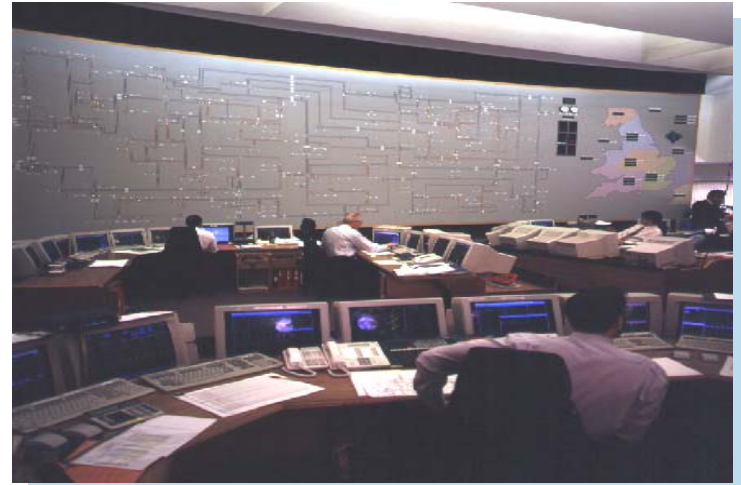

## System operator

- Operates the system
- Provides Customer Interface

# NGC Role as GBSO

- Energy Balancing
- System Balancing
- Contracting for Connection to and Use of GB Transmission System
- Setting and Collecting Transmission Charges

# Project Status

- BETTA consultations – started August 2000
- Energy Act - Royal Assent 22nd July 2004
- Go Active - 1st September 2004
- Go Live - 1st April 2005

# The GB Contractual/Regulatory Framework

**Ben Graff**

**Development Manager**

**Industry Codes**

National Grid Transco

# Agenda

- The Enduring Code Arrangements
- Elements of Transition

# Agenda

- The Enduring Code Arrangements
- Elements of Transition

# The Legislative and Contractual Framework - Electricity Market

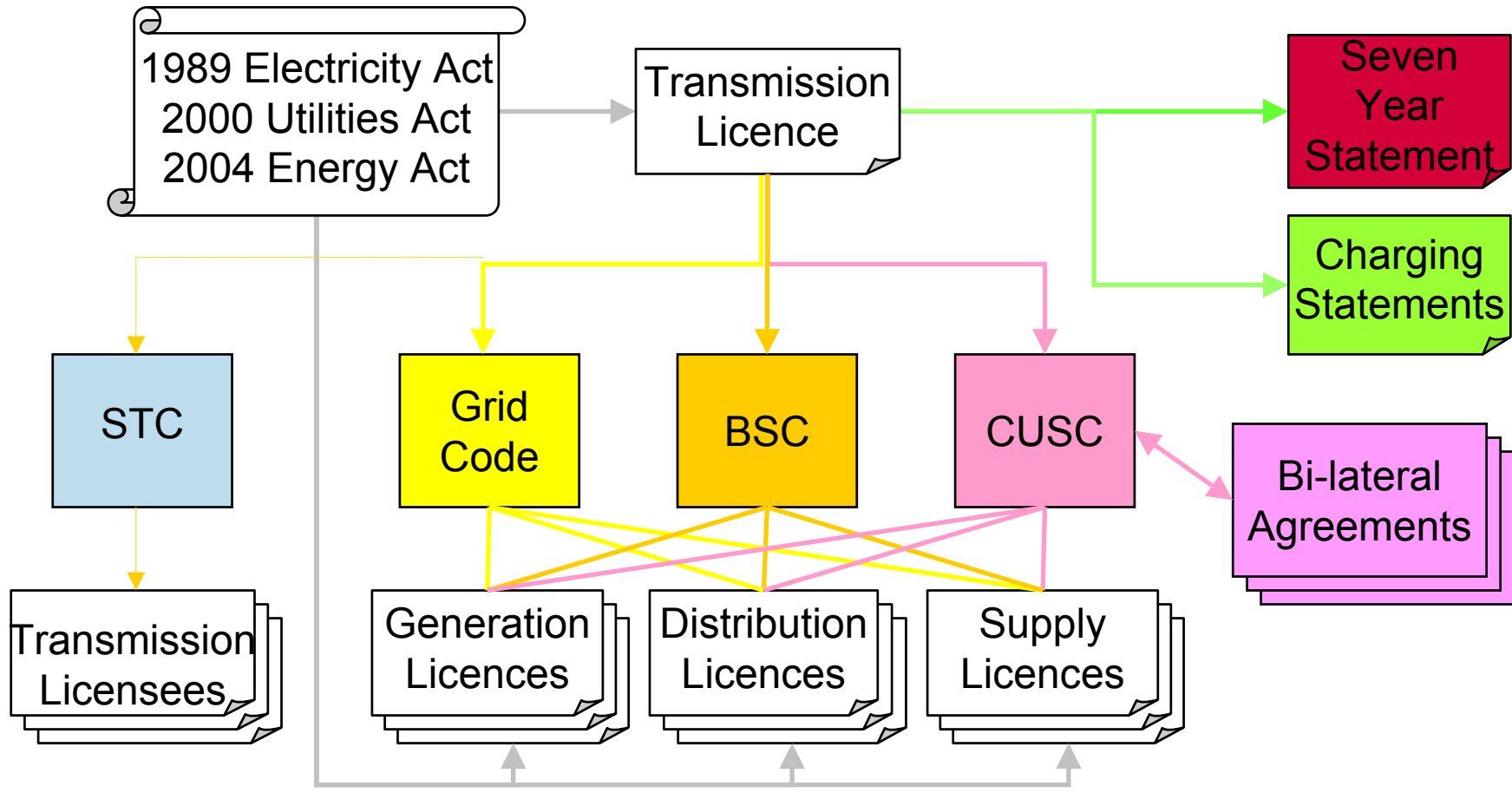

# Who needs to sign the CUSC?

- Licensees
- Users

# Key CUSC Sections

- Section 2 - Connection
- Section 3 - Use of System
- Section 4 - Ancillary Services
- Section 7 - Disputes
- Section 8 - Governance

# Key Grid Code Sections

- Planning Code
- Connection Conditions
- Operating Codes
- Balancing Codes
- Other sections
  - Data Registration Code
  - Glossary and Definitions
  - General Conditions

# Agenda

- The Enduring Code Arrangements
- Elements of Transition

# CUSC: Section 12 - Transition

- New Connection Applications
- Transition of Existing Agreements
- Other arrangements

# The GB Grid Code in Transition

- Current Applicability of the GB Grid Code
- Phasing in process
- Interaction with the Scottish Grid Code

# Run off of Existing Scottish TO Agreements and Changes to Existing DNO Agreements

Scottish and Southern Energy

**See separate presentation**

# Transition to GB Connection and Use of System Agreements

Paul Roberts, Commercial Manager

Guy Phillips, Connection Agreements Manager

Customer Agreements

# Agenda

- Transition process and timescales
- The GBSO Offer
- Allocation of GB Transmission System Access Rights

# Agenda

- Transition process and timescales
- The GBSO Offer
- Allocation of GB Transmission System Access Rights

# Principles of transition

- Obligations set out in Transmission Licences, CUSC and STC
- TOs to prepare “TO offers”
- GBSO offer must reflect TO offer
  - treatment of existing transmission access rights
  - existing ownership boundaries (unless Ofgem determines otherwise)
  - treatment of existing rights and restrictions, where able

# “Existing User” - Party with an Agreement with a Transmission Licensee at 1st Jan 2005

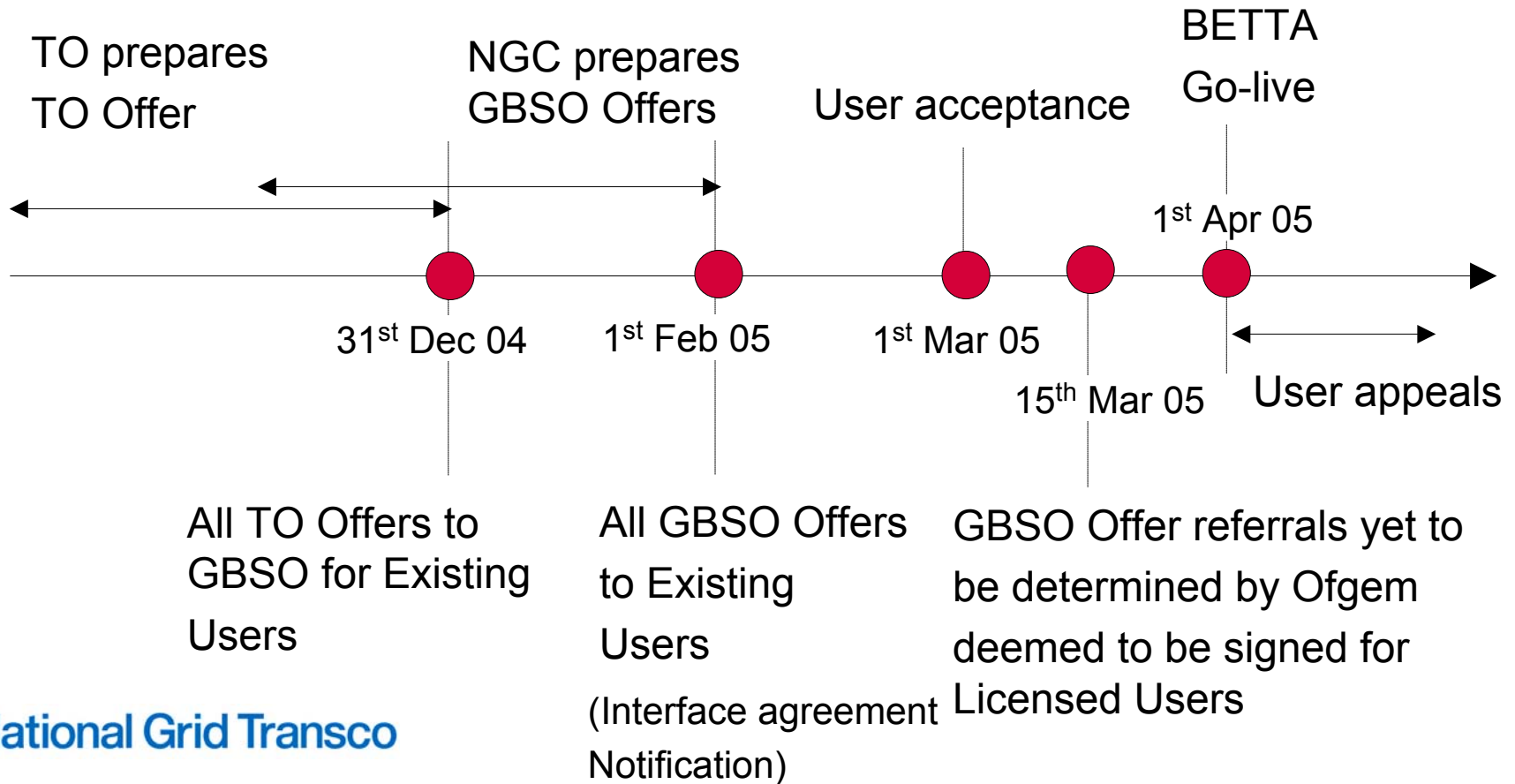

**“Existing Applicant”** - Party that has made an application during transitional period, but not accepted by 1<sup>st</sup> Jan 05

**NB. Timeline shows process for users with application or unsigned offer at 1<sup>st</sup> Jan 05**

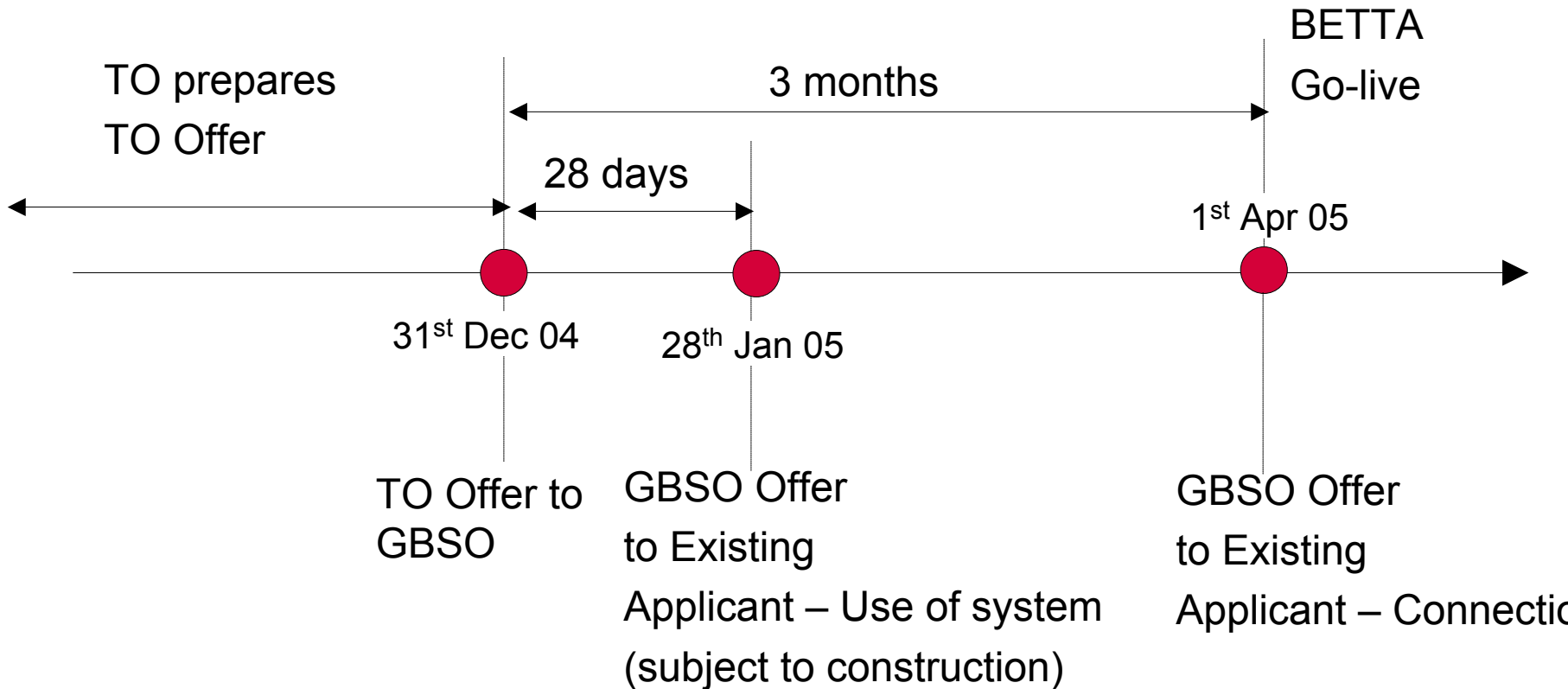

# Agenda

- Transition process and timescales
- **The GBSO Offer**
- Allocation of GB Transmission System Access Rights

# Types of CUSC Agreement

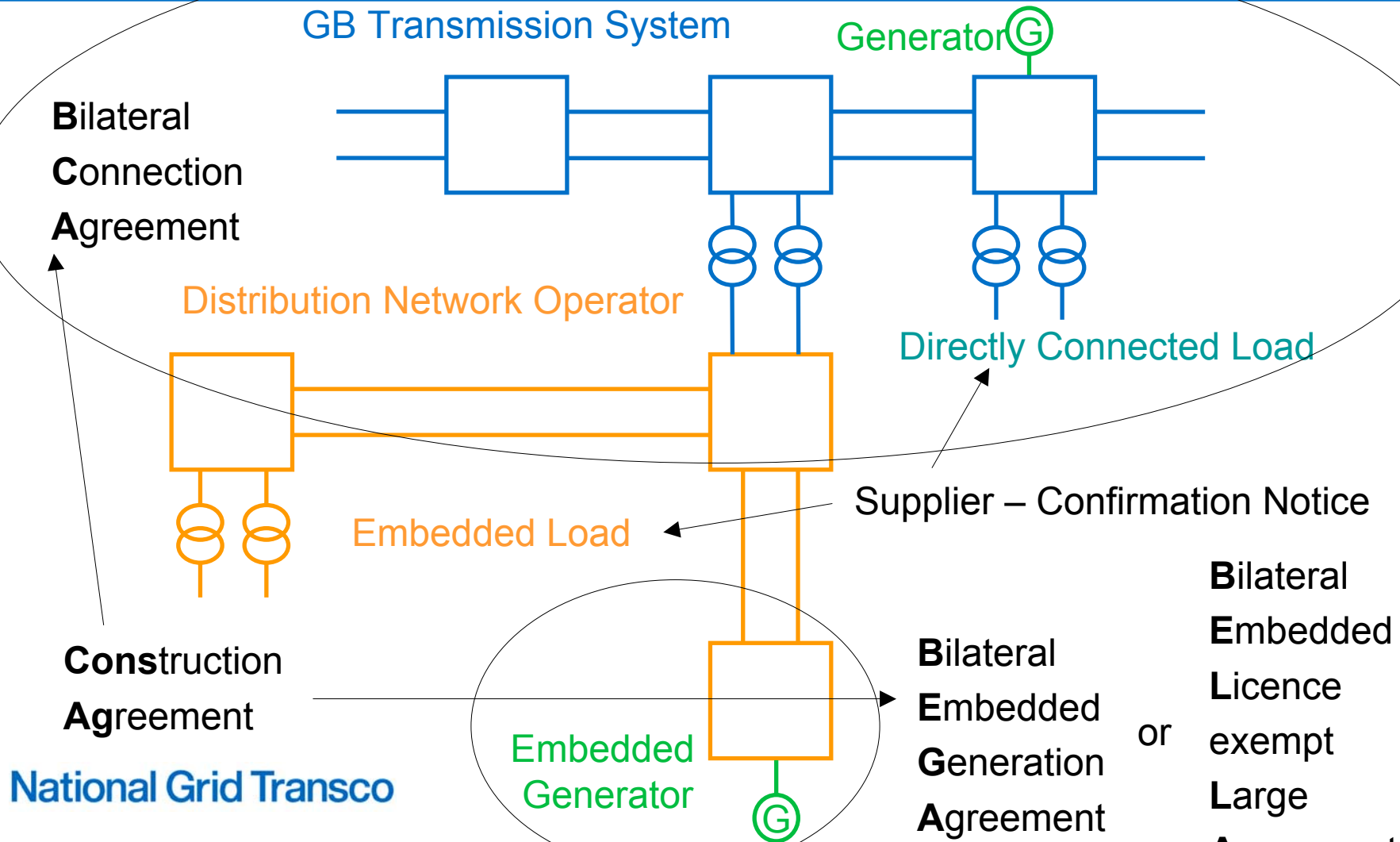

# Types of CUSC Agreement

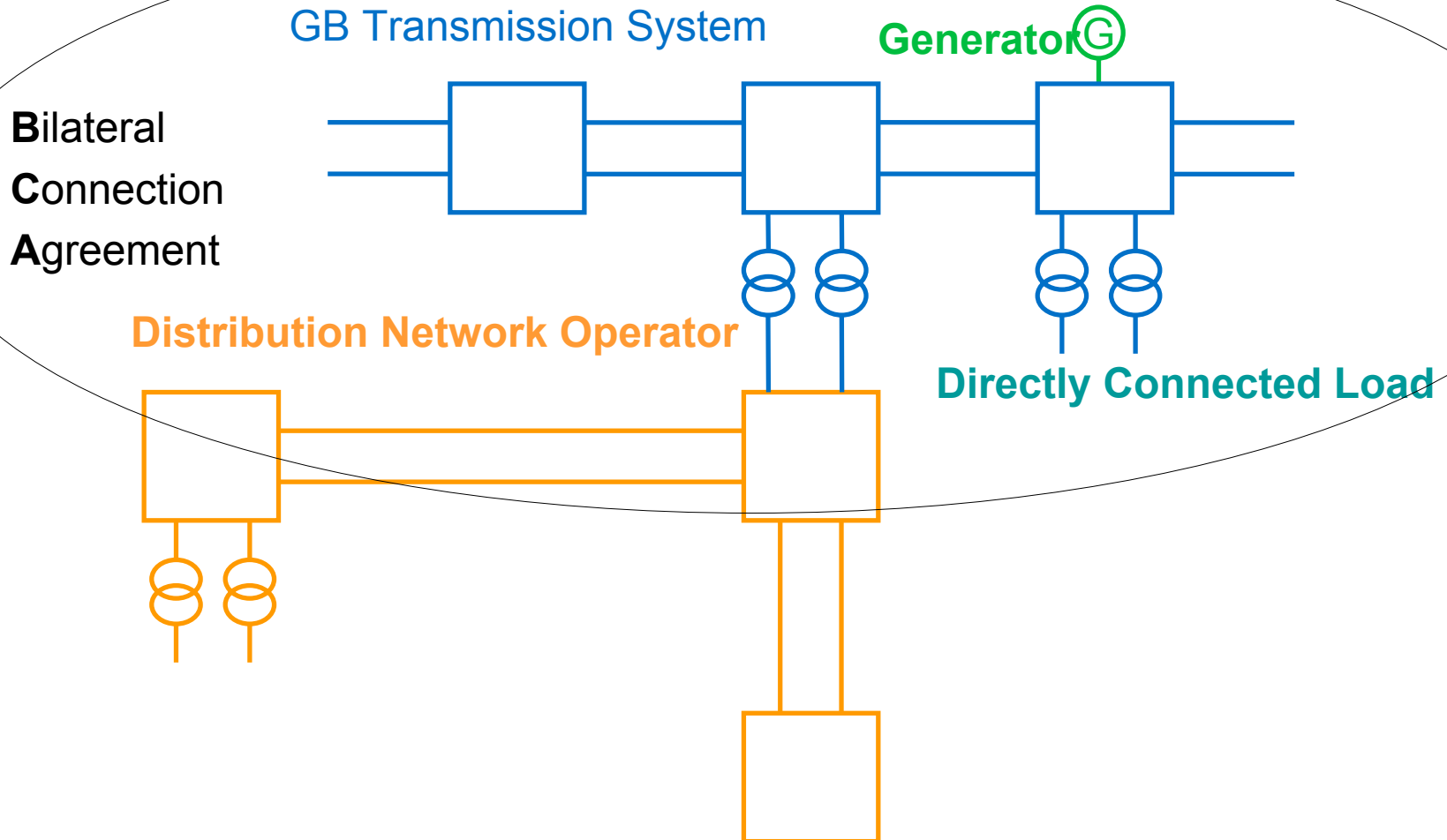

# Bilateral Connection Agreement (BCA) - Overview

- Who applies to?
  - Direct connectee to the GB Transmission System
- States Connection Charges
  - Based on list of chargeable transmission connection assets
- Rights to use the Transmission System (for generators and interconnector owners)
- Site Specific Technical Conditions
  - Required services
  - Information exchange
  - Grid Code/Security Quality of Supply Standard compliance

# Types of CUSC Agreement

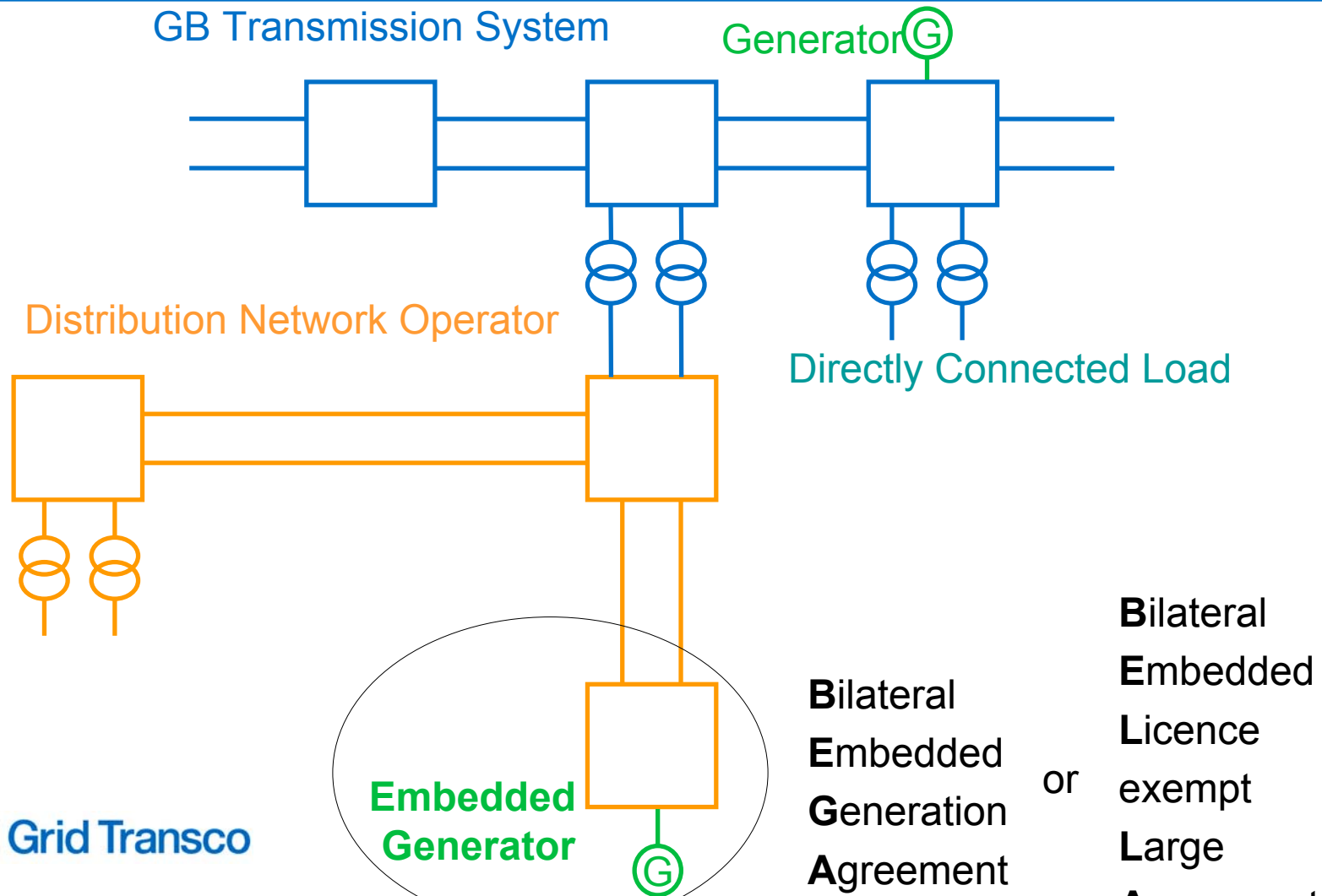

# Bilateral Embedded Generation Agreement (BEGA) - Overview

- Who applies to?
  - Distribution connectee that is a BM registrant
- States Connection Charges
  - Based on list of chargeable transmission connection assets
- Rights to use the Transmission System (for generators and interconnector owners)
- Site Specific Technical Conditions
  - Required services
  - Information exchange
  - Grid Code/Security Quality of Supply Standard compliance

# Bilateral Embedded Licence exemptable Large Agreement (BELLA) - Overview

- Who applies to?
  - Large Licence Exemptable Generators that are not BM registrants
  - See Ofgem consultation document
- States Connection Charges
  - Based on list of chargeable transmission connection assets
- Rights to use the Transmission System (for generators and interconnector owners)
- Site Specific Technical Conditions
  - Required services
  - Information exchange
  - Grid Code/Security Quality of Supply Standard compliance

# Mandatory Services Agreement

- Who applies to?
  - Required for large generating Units
- To be sent out with the GBSO Offer where timing is appropriate
- Mandatory Services are:
  - Reactive Power - default service terms and tender process
  - Frequency Response - Grid Code specified capability

# Construction Agreement

- Who applies to?
  - Party requiring transmission/connection works to facilitate connection/use of system
- Connection and/or Transmission System Infrastructure Works
- Construction Programme
- Completion Date
- Security requirements
- Termination

# Allocation of GB Transmission System Access Rights - Background

- Limited available capacity on GB Transmission System
- NGC Consultation - May 2004
  - NGC Technical Report - July 2004
- Ofgem Conclusion Document - August 2004
- GB Queue established in accordance with NGC Transmission Licence
- Connection Date and associated Transmission System Reinforcements might be different

# Allocation of GB Transmission System Access Rights - Categories

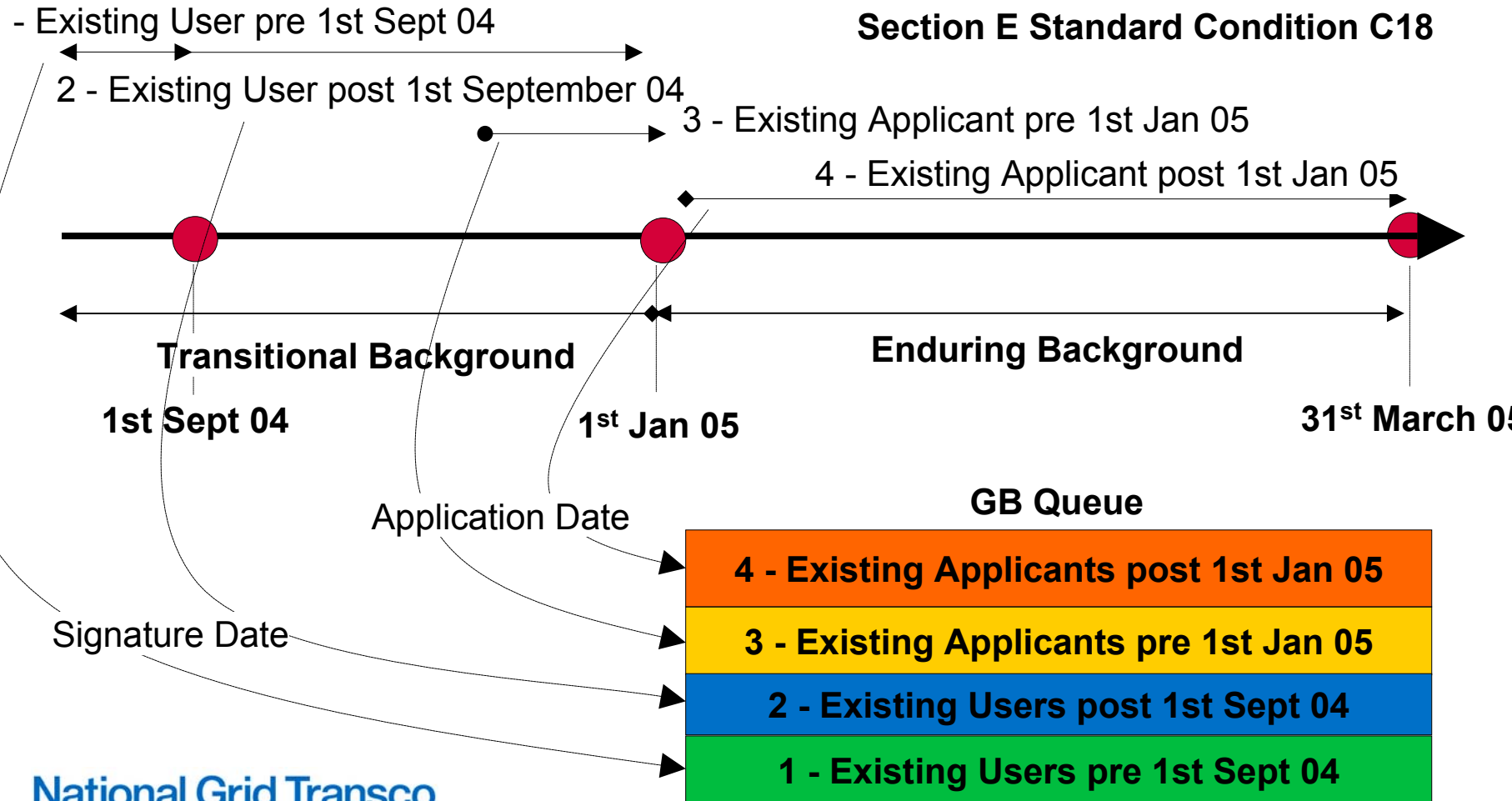

# Rights to use the GB Transmission System - Access Definitions

- Derived from existing Scottish contracted rights
- Connection Entry Capacity (CEC)
  - Maximum physical output of a generator on a station and unit basis.
  - Used for connection design
- Transmission Entry Capacity (TEC)
  - Access capacity that a generator requires to export onto the transmission system at a station level
  - Must be less than or equal to station CEC
  - Used for system planning and network development
  - Basis of Transmission Network Use of System (TNUoS) charges
  - TEC cannot be exceeded under CUSC/Generator Licence obligations

# Connection Security Requirements - Construction

- Connection Assets and contingent Transmission System Infrastructure (Appendix H1)
  - 'Final Sums'
  - Bi-Annual Estimate/Secured Amount Statement:
    - provided 75 days prior to 31st March to cover 6 months from 1st April
    - provided 75 days prior to 30th September to cover 6 months from 1st October
- NGC Credit Rating

# Connection Security Requirements – Connection and Use of System Charges

- Credit Rating for Existing Users
  - Confirm to NGC whether meet NGC Credit Rating by **17th January 2005**
  - User to put in place required security by **17th February 2005**
- Connection Charge - Termination Amounts
  - Value of connection assets
  - Clearing the Site
- Use of System Charge
  - 29 days BSUoS Charges for a Generator
  - 32 days BSUoS Charges + 10% of a Users Demand Reconciliation for a Supplier

# Deviation from Design Standard

- If fully compliant with SQSS GBSO Offers Firm Rights
- If not:
  - No CUSC compensation for disconnection
  - No constraint payments

# Revision of Offers

- Some Offers may be ‘interactive’
- Once GB Offer signed, Users can submit CUSC Modification Application
  - Position in GB Queue may change
- NGC also has right to amend Construction Agreements

# Transmission Charging under BETTA

Stuart Easterbrook

Transmission Charging Development Manager

*BETTA User Forum November 2004*

National Grid Transco

# Overview

- Framework for GB Transmission Charging
- Proposed GB Charging Methodology
  - Connection
  - Transmission Network Use of System (TNUoS)
  - Balancing Services Use of System (BSUoS)
- Small Gens/Hydro Benefit /Renewables in peripheral areas
- Next Steps

# GB Charging Framework (1)

- Ofgem/DTI Licence Framework Consultation
- Charges must achieve the relevant objectives:
  - facilitate effective competition in the generation and supply of electricity
  - ensure that charges are cost reflective
  - take account of developments in the business of the transmission licensees
  - facilitate competition in the carrying out of works for connection
- GBSO can propose changes to the methodology that better achieve the relevant objectives

## GB Charging Framework (2)

- Initial Thoughts Consultation - Dec 2003
- Initial Methodologies Consultation - April 2004
- Final Methodology Consultation - Aug 2004
- Final Methodology Conclusions - Sep 2004
- Ofgem consultation and Impact Assessment - Oct/Nov 04
- Authority decision Nov/Dec 2004

# Types of Charges

- Connection
  - Pays for individual Connections to the system
- Transmission Network Use of System (TNUoS)
  - Pays for Building & Maintaining Infrastructure
- Balancing Service Use of System (BSUoS)
  - Pays for Operating the System

# Who pays charges?

- Connection - Directly Connected Parties
  - Generators
  - Distribution Network Operators (DNOs)
  - Demand customers e.g. Steelworks
  - Interconnector Owners
- TNUoS
  - Generators (with Transmission Entry Capacity)
  - Suppliers
  - Interconnector Owners
- BSUoS - Balancing Mechanism Unit Lead Party
  - Generators
  - Suppliers
  - Interconnector Users

# Connection

# Shallow Connection Boundary: Plug and Socket

Plug = User's connection into substation = Connection

Socket = Substation = Infrastructure

Shared assets = Infrastructure

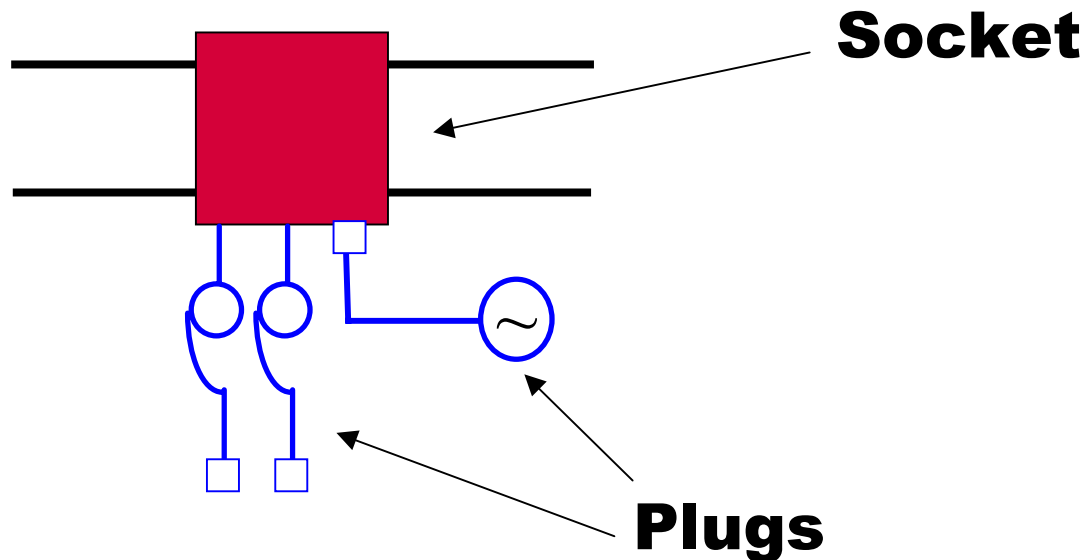

# Charge elements (Standard Terms)

- Asset based charge to recover the costs incurred in providing assets, installed solely for the use by an individual User, which afford connection to the transmission system
- Depreciation - normally over 40 years
- Rate of Return (on balance of asset value)
- Site Specific Maintenance
- Transmission Running Cost

**Finance**

**Running Cost**

# Transmission Network Use of System (TNUoS)

# TNUoS Methodology

- Recover cost of installing, running and maintaining the Transmission Network
- The transmission network is designed to cope with the maximum flows, therefore charges are based on “system peak” scenario
- Investment Cost Related Pricing - locational charges

# TNUoS Charging - Generation

- Transmission Entry Capacity (TEC) is set out in Bilateral Agreement
- Positive Zones - Charged on highest TEC during the year
- Negative Zones - Average of the 3 Highest Power Station Output Peaks, 10 days apart during November to February
- TEC is defined on a power station basis (includes station demand and additional load)
- If a generator is a Net Importer at time of Triad, demand charges are incurred.

# TNUoS Charging - Demand

- Based on demand at Triad - the three peak half hours of the year, separated by 10 clear days
- Half-hourly (HH) metered demand (large industrial and commercial customers) is charged on average demand at Triad
- Embedded small power stations are treated as negative demand and are therefore paid negative HH demand charges
- Non-half-hourly (NHH) metered demand (small commercial and domestic customers) is charged on daily consumption 4pm - 7pm
  - NHH tariff is derived from HH Triad Tariff

# Balancing Services Use of System (BSUoS)

# BSUoS Methodology

- Based on existing England and Wales methodology
- Recover costs incurred in the SO activity including:
  - operation of the transmission system
  - procurement and usage of Balancing Services for the purpose of balancing the transmission system
- Calculated for each Settlement Period (0.5hr)
- Costs allocated to 0.5hr where possible
- Based on “metered volumes”
- Dependency on design of GBSO Incentives

# Final Methodologies Conclusions Report - Recommendation

- Two Transmission Network Use of System methodologies proposed as achieving licence objectives
  - Preferred Multi Voltage option (Scenario B)
  - Alternative Single Voltage option (Scenario A)
- Single GB connection methodology
- Single BSUoS methodology

# Ofgem/Government Proposals

- Small Generators
  - Rebate on residual element of Generation TNUoS for 3 years from BETTA go-live
- Hydro Benefit
  - Ofgem announced the existing hydro benefit will end (within Scotland)
  - Government intend to reintroduce via GBSO
  - Live consultation
- Renewables
  - Adjustment to Generation TNUoS for qualifying renewable generators in a defined area

# Next steps - Indicative Timetable

- 12 November 04 - Ofgem consultation and Impact Assessment closes
- November 2004 - Authority decision
- End December 2004 - Indicative Connection charges
- January 2005 - Indicative tariffs
- 31 January 2005
  - Final Tariffs
  - Appendix A and B for connected parties
- January-February 2005: Statement of Use of System Charges
  - Application Fees

## Further Information

For GB Charging Issues:

[http://www.nationalgridinfo.co.uk/betta/gb\\_consultations.html](http://www.nationalgridinfo.co.uk/betta/gb_consultations.html)

For existing England and Wales Charges:

<http://www.nationalgridinfo.co.uk/charging/index.html>

# Questions and Answers Session

# Supporting Information

- NGC BETTA Website:

- <http://www.nationalgridinfo.co.uk/betta/index.html>

- Ofgem BETTA Websites:

- <http://www.ofgem.gov.uk/ofgem/work/index.jsp?section=/areasofwork/betta01> (Link to desingation text)
- <http://www.ofgem.gov.uk/ofgem/work/index.jsp?section=/areasofwork/betta02> (Link to Ofgem BETTA publications)

# Connection Agreement Managers

- **Bec Thornton** - SSE area
  - 01926 656386
  - [bec.thornton@ngtuk.com](mailto:bec.thornton@ngtuk.com)
- **Kay Ward** – SP Area
  - 01926 655149
  - [kay.ward@ngtuk.com](mailto:kay.ward@ngtuk.com)
- **Guy Phillips** - transitional arrangements
  - 01926 656339
  - [guy.phillips@ngtuk.com](mailto:guy.phillips@ngtuk.com)