

Electricity SO Incentives Initial Proposals for 1st April 2011

Appendices

Electricity SO Incentives: Initial Proposals for 1st April 2011

Appendices

These appendices should be read in conjunction with the document “Electricity SO Incentives: Initial Proposals for 1st April 2011”, available on the National Grid website:

<http://www.nationalgrid.com/uk/Electricity/soincentives/docs/>

Contents

| | | |
|----|--------------------------------------------------------------------------------|-----------|
| 1. | Appendix A: Energy Model Regression Coefficients and Back Testing | 3 |
| 2. | Appendix B: Treatment of Model Inputs | 25 |
| 3. | Appendix C: Modelled Transmission System Boundaries | 51 |
| 4. | Appendix D: List of Consultation Questions | 61 |

1. Appendix A: Energy Model Regression Coefficients and Back Testing

Introduction

The variables used for each regression within the various models that make up the Energy model are set out in Section 3. This Appendix contains, for each regression within the Energy model:

- the variables and coefficients that define the regression; and
- the back testing of each regression and its coefficients.

This Appendix assumes that the reader is familiar with, and has knowledge of, statistical modelling and back testing techniques.

Variables and Coefficients

The variables used within each model, and the rationale for doing so, are set out in Section 3. Within this Appendix a table of coefficients, standard errors and t-stats is presented for each regression model. The coefficient values are the most important numbers, in that they describe the model exactly. For example, the BM Start-up model has the coefficients as set out in Table 1 below:

| | | | |
|---------------------|----------|--------------|-----------------------|
| BM Start Up Costs = | Constant | Margin Price | Margin Price * Summer |
| Coefficient | -0.153 | 0.025 | 0.010 |
| Standard Error | 0.205 | 0.004 | 0.003 |
| Adjusted R-Squared | 68% | | |

Table 1: BM Start-Up Regression Coefficients

From the table above it can be determined that the mathematic model form is:

$$\text{BM Start-up} = 0.025 \times \text{Margin Price} + 0.01 \times \text{Margin Price} \times \text{Summer} - 0.153$$

One of the supplementary outputs from a regression model is an estimate of the standard error for each coefficient. Dividing the coefficient estimate by this value gives the t-stat (or z-stat). If the t/z-stat is close to zero (the usual boundary is within ± 1.96) then the variable should (usually) be removed from the regression as it is likely to be insignificant.

In addition, regression analysis output always includes an R-Squared value which essentially demonstrates the overall fit of the model. The closer this value is to 1, the more closely the model aligns with the observed data and the better relationship between the variables. The maximum value of R-Squared is 1. The R-Squared values are displayed for each model regression in the sections below.

In some cases, dummy variables have been used in the model regressions in order to test the significance of the variable in question. A dummy variable is one that takes the values 0 or 1 to indicate the absence or presence of a specific effect that may be expected to change the outcome of the model. For example, in order to test whether market length (NIV) had an impact on the BM Price/ SPNIRP regression a dummy variable was used to separate the data by market length. (This is explained further in the Energy Imbalance section below.)

Back Testing

Section 7 Appendices

In order to ensure that each model is robust and that output forecast costs reflect real costs of system operation as accurately as possible, the models are back tested to compare modelled data with actual data. There are two ways in which back testing is displayed:

- i. Source data back tests - In order to select over which time period source data should be used for the regression coefficients, a back test is performed for each year by comparing actual historical data with modelled data. The result is a table of percentage errors for each year as exemplified by Table 2 below for the BM Price model (from the Energy Imbalance model) which displays the percentage errors from the use of the specified variable coefficients over different timeframes.

| | | Percentage Errors for coefficient years | | | | |
|-----------------|---------|-----------------------------------------|---------|---------|---------|---------|
| | | 2009-10 | 2008-10 | 2007-10 | 2006-10 | 2005-10 |
| Financial Years | 2005-06 | -11.81% | 3.17% | 2.33% | 0.83% | 0.67% |
| | 2006-07 | 0.28% | 2.09% | 5.22% | 4.39% | 4.19% |
| | 2007-08 | -4.67% | -0.58% | 2.79% | 2.53% | 2.41% |
| | 2008-09 | -28.43% | -5.04% | -7.53% | -9.06% | -9.49% |
| | 2009-10 | 0.00% | 8.87% | 10.29% | 9.36% | 9.62% |

Table 2: BM Price model percentage errors for coefficient years

From the above table it can be seen that the use of 5 year data (2005-2010) results in lower percentage error as indicated by the numbers in the right hand column.

A table, such as the one illustrated by Table 2 above, is produced for each regression in the sections below. For some of the regressions used in the Energy model, the percentage errors do not necessarily explicitly support the use of 5 year source data. However, where this is the case, the use of 5 year source data does not significantly affect the accuracy of the coefficients and the general trend is that more source data produces more accurate results. Therefore, for consistency, 5 year source data has been used for all model regressions within the Energy model.

2010 has been used as the back testing baseline year in order to reflect the most recent system conditions.

- ii. Graphical back testing - following the outcome of the source data back tests, a graph is plotted to show modelled versus actual outturn data for the timeframe over which the source data was used. As set out above, 5 year historical data has been used within each regression and therefore each back testing graph shows 5 year actual data against the modelled figures. For each graph within this section, the blue line represents actual outturn data and the red line represents modelled data.

Energy Imbalance Model Coefficients and Back Testing

BM Price/ SPNIRP Regression

The Energy Imbalance model regression variables, with their coefficients, are shown in Figure 1 below. The regression uses SPNIRP and NIV which are to be input ex-post to the model. A dummy variable ('SHORT') was used to separate historical data according to market length i.e. SHORT has the value 1 when the market is short (or NIV is greater than zero) and 0 otherwise.

| Variable | Coefficient | Std. Error | t value |
|-------------------|-------------|------------|-----------|
| (Intercept) | -44.32000 | 0.78840 | -56.20900 |
| SPNIRP | -0.00888 | 0.00646 | -1.37500 |
| log(SPNIRP) | 20.94000 | 0.28050 | 74.65000 |
| SHORT | -78.21000 | 1.27900 | -61.12900 |
| SPNIRP:NIV | 0.00002 | 0.00001 | 1.80400 |
| log(SPNIRP):NIV | 0.00009 | 0.00013 | 0.69300 |
| SPNIRP:SHORT | 0.06166 | 0.00928 | 6.64500 |
| log(SPNIRP):SHORT | 27.08000 | 0.44690 | 60.60500 |

Section 7 Appendices

| | | | |
|-----------------------|---------|---------|----------|
| SPNIRP:NIV:SHORT | 0.00028 | 0.00001 | 21.22700 |
| log(SPNIRP):NIV:SHORT | 0.00237 | 0.00021 | 11.50000 |
| Adjusted R-Squared | 0.841 | | |

Figure 1: Energy Imbalance model regression variables and coefficients

Figure 2 shows the 5 year back test for modelled and actual BM prices whereby modelled prices correlate reasonably with actual historical prices.

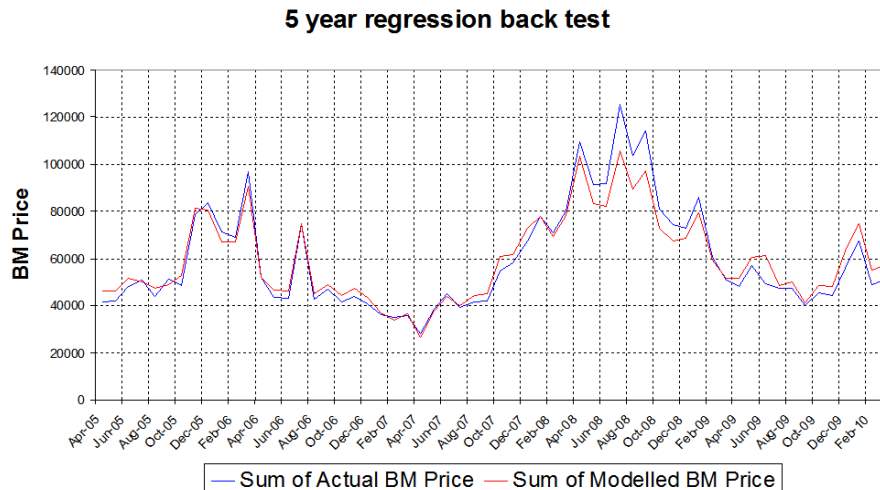

Figure 2: BM Price 5 Year Regression Back Test

Table 3 below shows the percentage errors from the use of the specified variable coefficients over different timeframes and illustrates that the use of 5 years of historical data for selecting the coefficients brings least error i.e. lower percentages. The errors signify the difference between the mean BM price for actual and modelled data.

| | | Percentage Errors for coefficient years | | | | |
|-----------------|---------|-----------------------------------------|---------|---------|---------|---------|
| | | 2009-10 | 2008-10 | 2007-10 | 2006-10 | 2005-10 |
| Financial Years | 2005-06 | -11.81% | 3.17% | 2.33% | 0.83% | 0.67% |
| | 2006-07 | 0.28% | 2.09% | 5.22% | 4.39% | 4.19% |
| | 2007-08 | -4.67% | -0.58% | 2.79% | 2.53% | 2.41% |
| | 2008-09 | -28.43% | -5.04% | -7.53% | -9.06% | -9.49% |
| | 2009-10 | 0.00% | 8.87% | 10.29% | 9.36% | 9.62% |

Table 3: BM Price model percentage errors for coefficient years

Energy Imbalance Cost

Having back tested the BM Price/ SPNIRP relationship as set out above, the total Energy Imbalance cost forecast model (including NIV) was then back tested for which the results are shown in Figure 3 below.

5 year regression back test

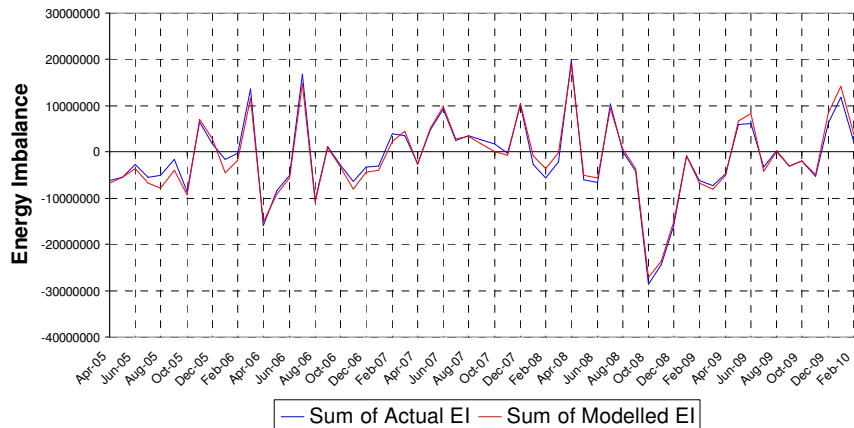

Figure 3: Energy Imbalance cost model back testing

Margin Model Coefficients and Back testing

Margin Modelling Formulae

Below are some equations that describe top-level margin requirements. The first equation is the situation we need the system to, ideally, always meet. If this is not met then margin actions must be taken, which is what the second equation represents. Various substitutions and re-arrangements result in the last equation, showing that it would be logical to try and model margin on NIV and headroom. The steps between each formula are set out below.

- 1) $\sum MEL \geq DF + STORR$
- 2) $\sum MEL + Margin = DF + STORR$
- 3) $Margin = DF - \sum MEL + STORR$
- 4) $Margin = STORR - \sum MEL + \sum FPN + NIV$
- 5) $Margin = STORR - Headroom + NIV$
- 6) $Margin = Requirement + NIV - Headroom$

- 1) As stated above, ideally, the sum of all MELs submitted in the Balancing Mechanism will be greater than or equal to the demand forecast plus a Short Term Operating Reserve Requirement (STORR) to account for unforeseen losses in generation or increases in demand.
- 2) If, therefore, the sum of all submitted MELs in the BM is less than demand plus the STORR, then margin actions must be taken. This then means that the sum of all MELs plus margin actions will be equal to the demand forecast plus the STORR.
- 3) Rearranging the previous equation shows that the volume of margin actions required will be equal to the demand forecast less the sum of all MELs, plus the STORR.
- 4) The demand forecast, in real time, equates to the sum of all FPNs submitted in the BM plus the NIV as the NIV reflects actions taken to balance the generation output with demand. This equation therefore achieves the same as the previous equation but replaces the demand forecast with the sum of FPNs plus the NIV.
- 5) Headroom (or Operating Reserve) is created where the sum of all MELs is greater than the sum of all FPNs which in turn reduces the requirement for margin actions. Therefore the function is reduced to STORR less the amount of ‘free’ operating reserve created by the market (or headroom), plus the NIV.

Section 7 Appendices

- 6) Rearranging the above equation leads to margin actions equating to the STORR plus the NIV, less the amount of headroom created by the market.

Hence, the margin forecast is modelled upon NIV, headroom and (the various elements of) STORR.

Margin Volume

The primary element of the margin volume model is a modelled margin volume, NIV and headroom relationship for which the variables and coefficients are shown below in Table 1.

| Variable | Coefficient | Std. Error | z value |
|--------------------------|-------------|------------|---------|
| PEAK.WINTER | 220.13647 | 2.77724 | 79.26 |
| PEAK.SUMMER | 197.43230 | 2.168688 | 91.04 |
| EFA6.SUMMER | 390.41716 | 4.581665 | 85.21 |
| PEAK.WINTER*NIV_MWH | 0.33474 | 0.004039 | 82.88 |
| PEAK.WINTER*HEADROOM_MWH | -0.06344 | 0.002953 | -21.48 |
| NIV_MWH*PEAK.SUMMER | 0.44274 | 0.004155 | 106.55 |
| HEADROOM_MWH*PEAK.SUMMER | -0.03281 | 0.003085 | -10.63 |
| NIV_MWH*EFA6.SUMMER | 0.35922 | 0.006927 | 51.86 |
| HEADROOM_MWH*EFA6.SUMMER | -0.14810 | 0.006349 | -23.32 |

Table 4: Margin volume regression variables and coefficients

The above table shows that the model uses the variables NIV and headroom, plus five further dummy variables. The dummy variables represent different EFA blocks and summer/winter differentials as the margin volume requirements over these periods can change. The dummy variables are detailed in Table 5 below where, for example, PEAK.WINTER literally refers to peak times in winter:

| Dummy Variable | Definition |
|----------------|------------------------------|
| PEAK.WINTER | EFA blocks 3 to 5 and winter |
| PEAK.SUMMER | EFA blocks 3 to 5 and summer |
| EFA6.SUMMER | EFA block 6 and summer |

Table 5: Margin volume regression dummy variables

Table 6 below shows the percentage errors from the use of the specified variable coefficients over different timeframes.

| | | Percentage Errors for coefficient years | | | | |
|-----------------|---------|-----------------------------------------|---------|---------|---------|---------|
| | | 2009-10 | 2008-10 | 2007-10 | 2006-10 | 2005-10 |
| Financial Years | 2005-06 | -25% | -15% | -15% | -17% | -12% |
| | 2006-07 | 12% | 27% | 27% | 25% | 32% |
| | 2007-08 | -5% | 8% | 8% | 6% | 11% |
| | 2008-09 | -14% | -3% | -3% | -4% | 0% |
| | 2009-10 | 15% | 28% | 28% | 26% | 32% |

Table 6: Margin volume percentage errors for coefficient years

The back testing of the margin volume regression can be found in the graph in Figure 4 below (please note that this is purely a back test of the margin volume regression and does not take into account the addition of STOR, wind for reserve, static frequency response or CMM elements).

5 year regression back test

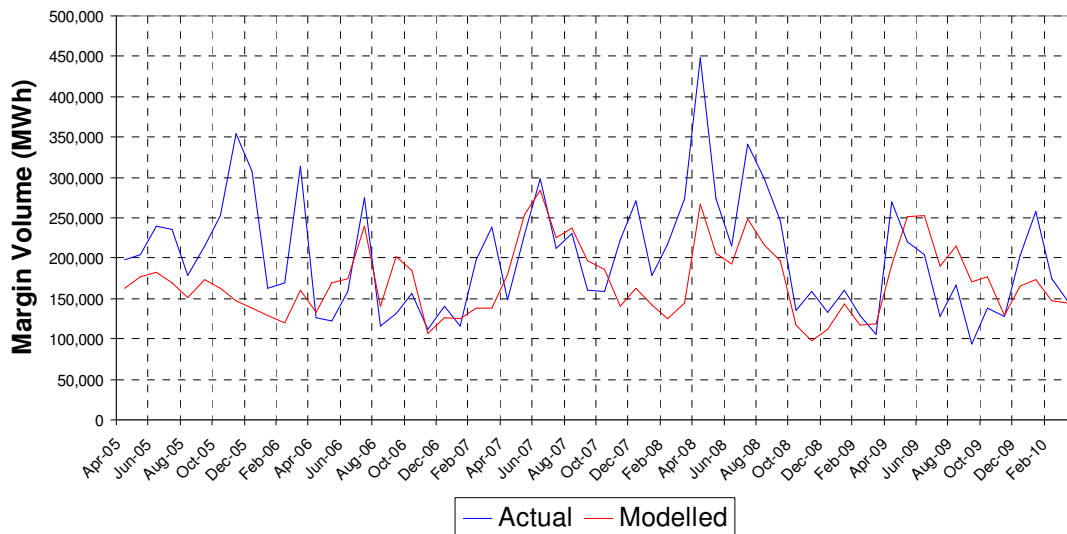

Figure 4: Margin Volume regression back testing

As set out in Section 3, Margin Volume in the Margin model is adjusted by STOR, static frequency response/ FFR and a reserve for wind % policy. The graph below in Figure 5 illustrates the back testing result of the Margin Volume model following adjustment for these elements. (Please note however that this excludes the further adjustment made for Constrained Margin Management or CMM.)

5 year regression back test

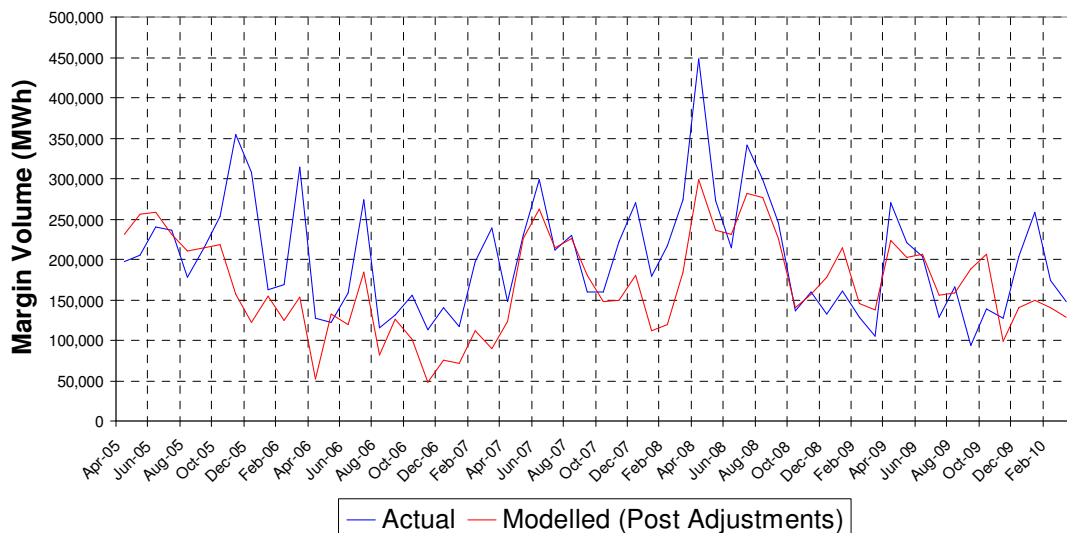

Figure 5: Margin Volume model back testing post STOR, static frequency response/ FFR, reserve for wind policy adjustments

Margin Price

The margin price model uses a similar relationship to that for margin volume i.e. with NIV, headroom, but has an additional element which is SPNRIP. The variables and coefficients for this regression can be found in Table 7 below:

| Variable | coefficient | Std. Error | t value |
|----------|-------------|------------|---------|
|----------|-------------|------------|---------|

Section 7 Appendices

| | | | |
|-------------------------------------|----------|---------|---------|
| PEAK.SUMMER | -1.64900 | 0.78790 | -2.092 |
| EFA6.SUMMER | 7.11200 | 1.38100 | 5.151 |
| PEAK.WINTER | -5.98500 | 1.07100 | -5.589 |
| PEAK.SUMMER * SPNIRP | 0.92040 | 0.01818 | 50.631 |
| PEAK.SUMMER * SPNIRP * NIV_MWH | -0.00124 | 0.00004 | -31.019 |
| PEAK.SUMMER * SPNIRP * MARGIN_MWH | 0.00027 | 0.00004 | 6.598 |
| PEAK.SUMMER * NIV_MWH | 0.01157 | 0.00200 | 5.771 |
| EFA6.SUMMER * SPNIRP | 0.92390 | 0.02451 | 37.699 |
| EFA6.SUMMER * SPNIRP * NIV_MWH | -0.00072 | 0.00006 | -12.339 |
| EFA6.SUMMER * SPNIRP * HEADROOM_MWH | -0.00021 | 0.00004 | -5.219 |
| EFA6.SUMMER * NIV_MWH | -0.00934 | 0.00323 | -2.896 |
| PEAK.WINTER * SPNIRP | 1.15900 | 0.02382 | 48.649 |
| PEAK.WINTER * SPNIRP * NIV_MWH | -0.00114 | 0.00004 | -32.204 |
| PEAK.WINTER * SPNIRP * MARGIN_MWH | 0.00035 | 0.00004 | 8.884 |
| PEAK.WINTER * NIV_MWH | 0.00587 | 0.00204 | 2.88 |
| Adjusted R-Squared | 0.5115 | | |

Table 7: Margin Price model Regression Variables and Coefficients

The back testing of the margin price regression can be found in Table 8 and Figure 6 below:

| | | Percentage errors for coefficient years | | | | |
|-----------------|---------|-----------------------------------------|---------|---------|---------|---------|
| | | 2009-10 | 2008-10 | 2007-10 | 2006-10 | 2005-10 |
| Financial Years | 2005-06 | 36.63% | 37.39% | 29.16% | 28.06% | 21.01% |
| | 2006-07 | 8.57% | -0.53% | -8.66% | -5.59% | -12.10% |
| | 2007-08 | 30.69% | 21.05% | 10.26% | 10.92% | 3.44% |
| | 2008-09 | -19.19% | 2.94% | 1.99% | 3.00% | 1.37% |
| | 2009-10 | 0.00% | -5.93% | -14.12% | -12.10% | -17.88% |

Table 8: Margin Price regression back testing

5 year regression back test

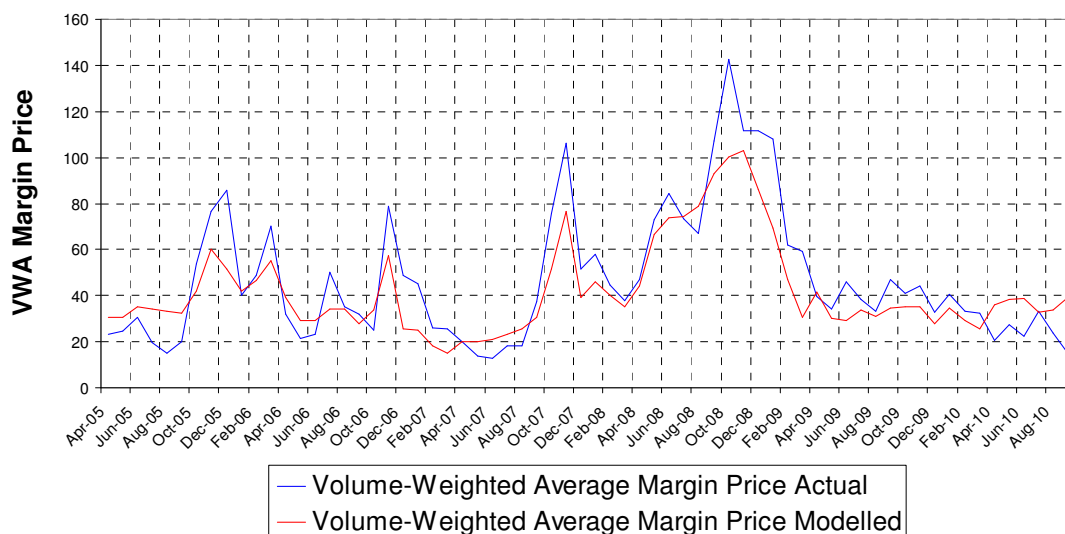

Figure 6: Margin Price regression back testing

BM Start Up

The regression coefficients for the BM Start Up cost forecast model are in Table 9 below (Margin Price * Summer means that, in the summer, the coefficient multiplying margin price is 0.025+0.010).

| BM Start Up Costs = | Constant | Margin Price | Margin Price * Summer |
|---------------------|----------|--------------|-----------------------|
| Coefficient | -0.153 | 0.025 | 0.010 |
| Standard Error | 0.205 | 0.004 | 0.003 |
| Adjusted R-Squared | 68% | | |

Table 9: BM Start Up regression coefficients

The graph below in Figure 7 displays the actual cost of BM Start Up against the modelled values. Note: Data only after November 2006 is employed as this is when the BM Start Up product was introduced, replacing the old Warming service.

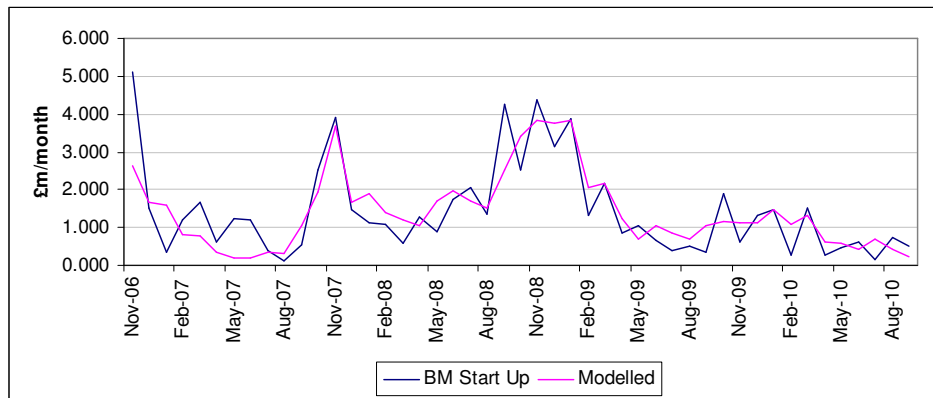

Figure 7: BM Start Up and volume of all Operating Reserve actions since November 2006

Constrained Margin Management

The coefficients for the Constrained Margin Management regression can be found in Table 10 below. The 'Volume' variable is the volume of bids taken to relieve Scottish constraints (in GWh) for that month.

| Variable | Coefficient | Std. Error | t value |
|-------------|-------------|------------|----------|
| (Intercept) | 7.11600 | 5.27300 | 1.34900 |
| Volume | 0.17040 | 0.12080 | 1.41000 |
| Volume ^2 | 0.00098 | 0.00044 | 2.21000 |
| Volume ^3 | -5.384E-07 | 3.751E-07 | -1.43500 |

Table 10: Constrained Margin Management regression coefficients

Margin Cost

The outcome of the above margin volume and margin price regressions (half-hourly) are multiplied together to obtain a margin cost (please note that this does not therefore include any of the margin adjusters such as STOR, CMM and static frequency response/FFR. The back testing results of this multiplication can be found below in Figure 8.

5 year regression back test

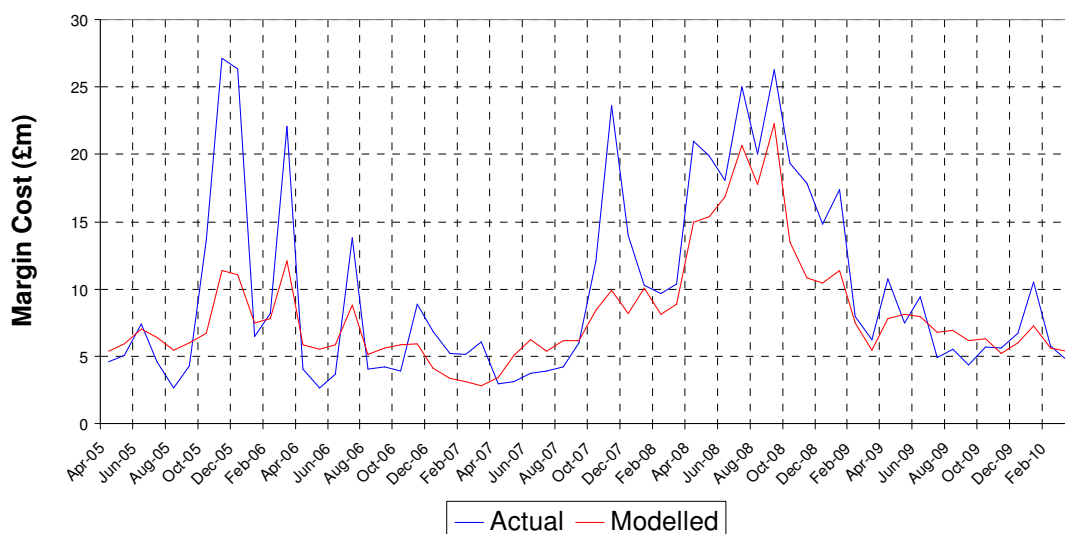

Figure 8: Margin Cost model regression back testing (without STOR, static frequency response/ FFR, wind, CMM or BM start-up elements)

As set out in Section 3, Margin Cost is adjusted to take into account STO, static frequency response/ FFR and wind elements using a monthly volume weighted average price of margin. The graph in Figure 9 below shows the back testing results for margin cost which has been adjusted for these elements. (Please note that this back testing excludes further adjustment to be made for CMM and BM Start-up in the margin cost model.)

5 year regression back test

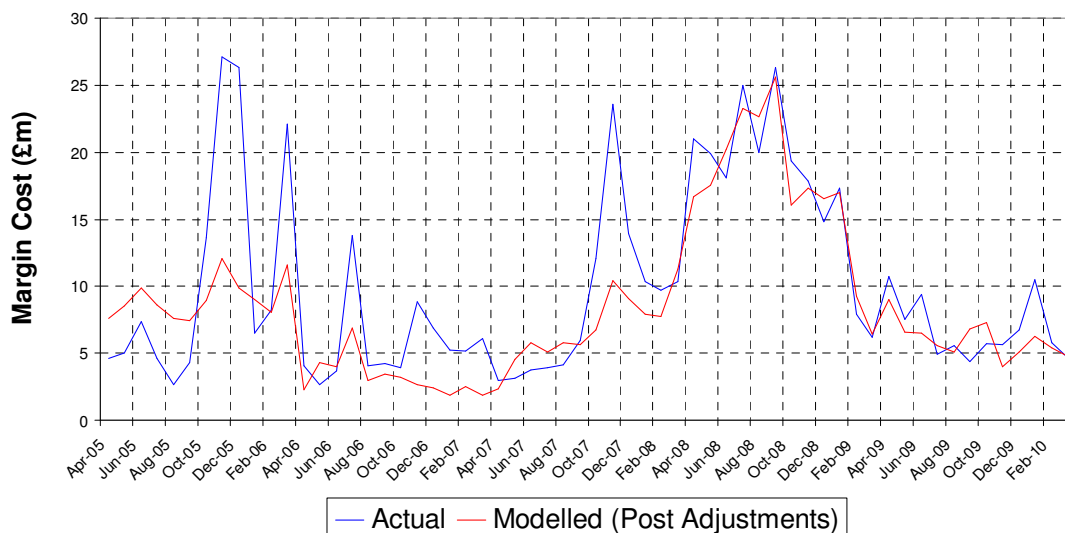

Figure 9: Margin Cost model regression back testing (including STOR, static frequency response/ FFR, wind adjustments)

Fast Reserve Model Coefficients and Back-testing

Fast Reserve Bid Volume

The coefficients for the Fast Reserve bid volume model are set out in Table 11 below:

Section 7 Appendices

| Fast Reserve Bid Volume | | | |
|-------------------------|-------------|------------|---------|
| Variable | Coefficient | Std. Error | t value |
| (Intercept) | 8.65335 | 12.92414 | 0.67 |
| WINTER * AVG_WIND | 0.28929 | 0.06058 | 4.776 |
| TREND | 1.30996 | 0.38793 | 3.377 |
| Adjusted R-Squared | | 0.4445 | |

Table 11: Fast Reserve Bid Volume model coefficients

The back testing for the above regression can be found in Table 12 and Figure 11 below:

| | | Percentage errors for coefficient years | | | | |
|-----------------|---------|-----------------------------------------|---------|---------|---------|---------|
| | | 2009-10 | 2008-10 | 2007-10 | 2006-10 | 2005-10 |
| Financial Years | 2005-06 | -2100.00% | 554.50% | 289.00% | 65.00% | 24.00% |
| | 2006-07 | -690.00% | 188.30% | 106.00% | 36.00% | 24.00% |
| | 2007-08 | -260.00% | 34.80% | 8.00% | -12.00% | -15.00% |
| | 2008-09 | -110.00% | -6.60% | -14.00% | -19.00% | -19.00% |
| | 2009-10 | 0.00% | 8.00% | 11.00% | 18.00% | 21.00% |

Table 12: Fast Reserve Bid Volume model regression back testing for coefficient years

5 year regression back test

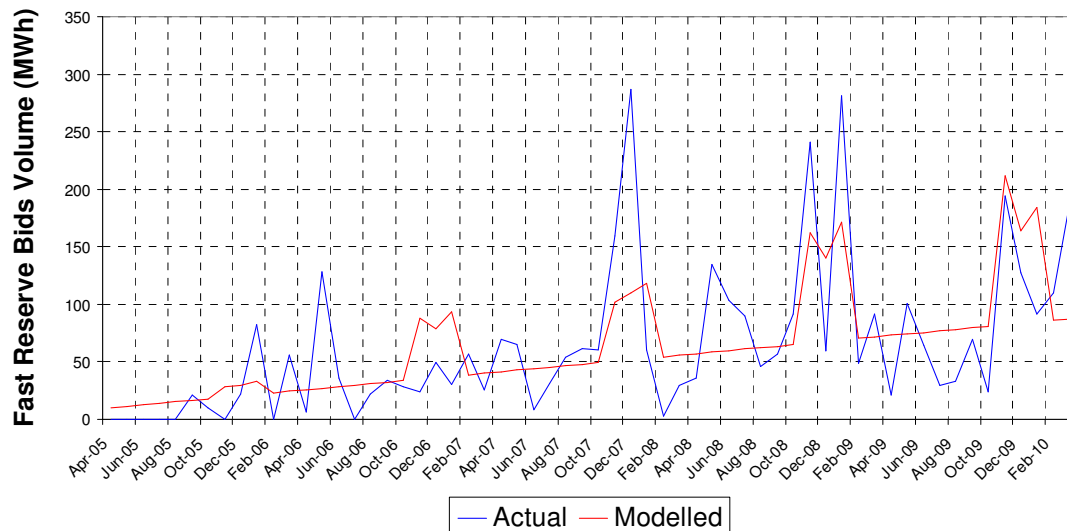

Figure 10: Fast Reserve Bid Volume model regression back testing

Fast Reserve Bid Cost

The back-testing for the Fast Reserve Bid cost model (the outcome of the bid volume regression as set out above multiplied by ex-ante forecast price as set out in Section 3) can be found below in Table 13 and Figure 11 below.

| | | Percentage errors for coefficient years | | | | |
|-----------|---------|-----------------------------------------|---------|---------|---------|---------|
| | | 2009-10 | 2008-10 | 2007-10 | 2006-10 | 2005-10 |
| Financial | 2005-06 | -866.29% | 149.17% | 48.07% | -37.07% | -52.89% |

Section 7 Appendices

| | | | | | | |
|-------|----------------|----------|---------|---------|---------|---------|
| Years | 2006-07 | -712.54% | 201.09% | 114.75% | 41.55% | 29.24% |
| | 2007-08 | -188.71% | -23.53% | -38.72% | -49.99% | -51.58% |
| | 2008-09 | -105.50% | -57.69% | -61.24% | -63.21% | -63.13% |
| | 2009-10 | 0.00% | 8.05% | 10.80% | 17.92% | 20.71% |

Table 13: Fast Reserve Bid cost model back testing

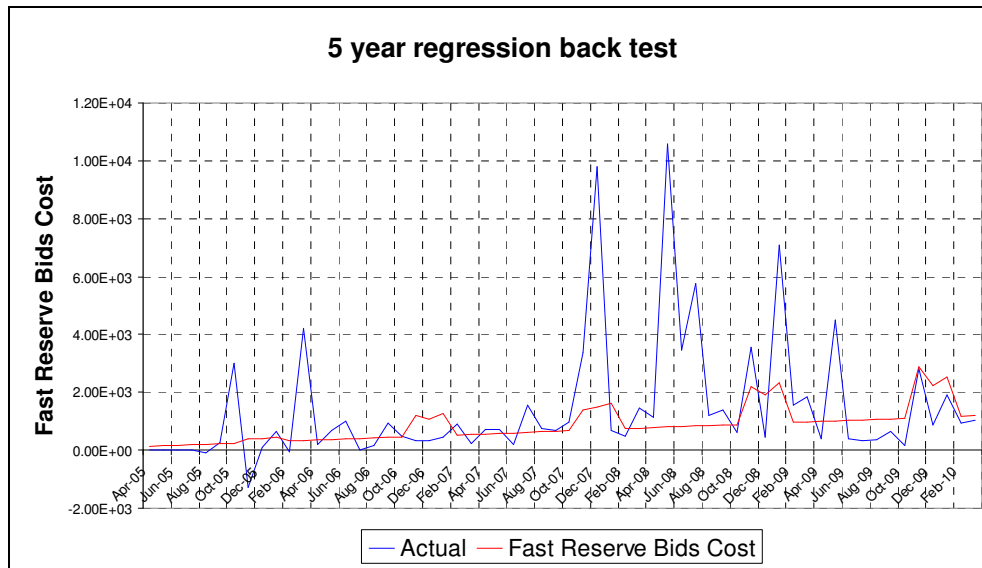

Figure 11: Fast Reserve Bid cost model back testing

Fast Reserve Offer Volume

The coefficients for the Fast Reserve offer volume model are set out in Table 14 below:

| Fast Reserve Offer Volume | | | |
|----------------------------------|---------------------|-------------------|----------------|
| Variable | Coefficients | Std. Error | t value |
| (Intercept) | 8889.70900 | 633.461 | 14.034 |
| WINTER * AVG_WIND | 13.50100 | 2.969 | 4.547 |
| TREND | 55.69400 | 19.014 | 2.929 |
| Adjusted R-Squared | 0.4026 | | |

Table 14: BM Fast Reserve Offer Volume coefficients

The back testing for the above Fast Reserve Offer volume regression can be found in Table 15 and Figure 12 below:

| | | Percentage errors for coefficient years | | | | |
|-----------------|----------------|-----------------------------------------|----------------|----------------|----------------|----------------|
| | | 2009-10 | 2008-10 | 2007-10 | 2006-10 | 2005-10 |
| Financial Years | 2005-06 | 37.00% | -55.55% | -32.03% | 11.90% | 5.30% |
| | 2006-07 | 4.10% | -46.51% | -33.48% | -10.90% | -14.20% |
| | 2007-08 | 26.00% | -13.80% | -3.98% | 11.60% | 9.50% |
| | 2008-09 | 17.00% | -0.90% | 3.37% | 7.30% | 7.10% |
| | 2009-10 | 0.00% | 0.75% | 0.16% | -5.10% | -3.80% |

Table 15: Fast Reserve Offer volume regression back testing

5 year regression back test

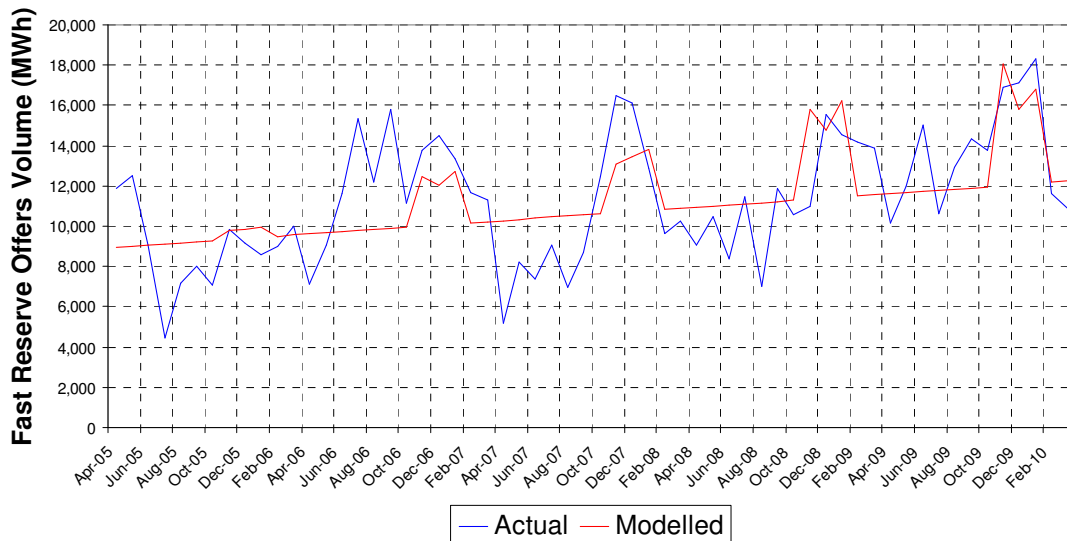

Figure 12: Fast Reserve Offers volume regression back testing

Fast Reserve Offer Cost

The back testing of the Fast Reserve Offer cost model (the outcome of the offer volume regression as set out above multiplied by an ex-ante forecast price as set out in Section 3) can be found below in Table 16 and Figure 13.

| | | Percentage errors for coefficient years | | | | |
|-----------------|---------|-----------------------------------------|---------|---------|---------|---------|
| | | 2009-10 | 2008-10 | 2007-10 | 2006-10 | 2005-10 |
| Financial Years | 2005-06 | 59.51% | -48.18% | -20.75% | 30.45% | 22.73% |
| | 2006-07 | 23.04% | -36.77% | -21.36% | 5.34% | 1.47% |
| | 2007-08 | 66.45% | 14.16% | 27.16% | 47.73% | 45.01% |
| | 2008-09 | 51.04% | 28.38% | 33.90% | 38.97% | 38.71% |
| | 2009-10 | 0.00% | 0.75% | 0.16% | -5.06% | -3.84% |

Table 16: Fast Reserve Offer Cost model back testing

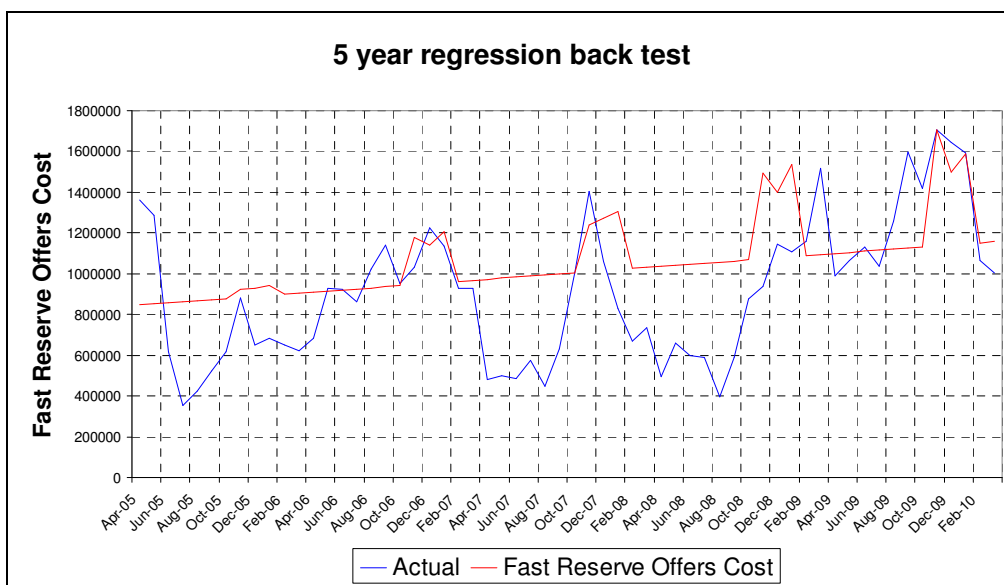

Figure 13: Fast Reserve Offer Cost model back testing

Fast Reserve Ancillary Services Cost

The coefficients of the Fast Reserve Ancillary Services Cost regression can be found in Table 17 below.

| Variables | Coefficients | Std. Error | t value |
|---------------------|--------------|------------|---------|
| (Intercept) | 3.37952 | 0.1483919 | 22.774 |
| AVG_WIND | 0.00139 | 0.0004566 | 3.033 |
| WINTER * AVG_SPNIRP | 0.00623 | 0.0025524 | 2.442 |
| SUMMER | -0.32418 | 0.1215699 | -2.667 |
| AVG_SPNIRP | 0.00665 | 0.0029189 | 2.279 |
| Adjusted R-Squared | 0.4431 | | |

Table 17: Fast Reserve Ancillary Services Cost Model Coefficients

The back testing of the Fast Reserve Ancillary Services cost model can be found in Table 18 and Figure 14 below.

| | | Percentage errors for coefficient years | | | | |
|-----------------|---------|-----------------------------------------|---------|---------|---------|---------|
| | | 2009-10 | 2008-10 | 2007-10 | 2006-10 | 2005-10 |
| Financial Years | 2005-06 | 19.35% | 12.09% | 16.54% | 12.23% | 6.42% |
| | 2006-07 | -2.17% | 3.68% | 6.40% | 3.30% | -0.67% |
| | 2007-08 | -3.26% | -3.36% | -1.05% | -3.39% | -6.09% |
| | 2008-09 | 31.41% | -1.14% | -0.32% | -0.60% | -0.24% |
| | 2009-10 | 0.00% | 1.21% | 1.43% | 1.01% | 1.50% |

Table 18: Fast Reserve Ancillary Services cost model back testing

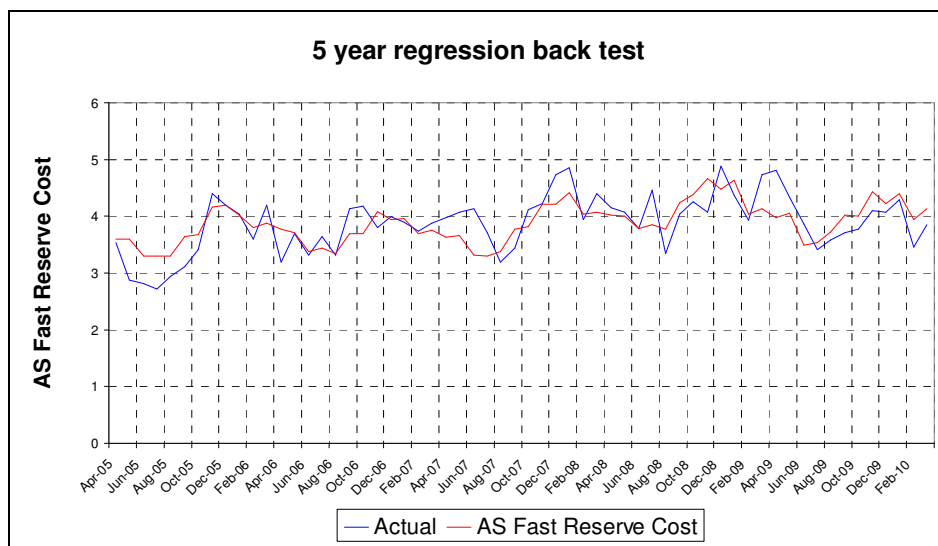

Figure 14: Fast Reserve Ancillary Services Cost model back testing results

Frequency Response Model Coefficients and Back-testing

Ancillary Services Response Cost

Section 7 Appendices

The coefficients and back testing for the Ancillary Services Response costs are set out in Table 19, Table 20 and Figure 15 below.

| Variables | Coefficients | Std. Error | t value |
|--------------------|--------------|------------|----------|
| (Intercept) | 11.89000 | 1.27400 | 9.33500 |
| TREND | 0.04089 | 0.01528 | 2.67600 |
| RESPONSE_O_MWH | -0.00003 | 0.00001 | -5.70200 |
| SUMMER * AVG_WIND | 0.01304 | 0.00425 | 3.06600 |
| RESPONSE_B_MWH | -0.00001 | 0.00000 | -2.87700 |
| Adjusted R-Squared | 0.5187 | | |

Table 19: Ancillary Services Response Cost Model Coefficients

| | | Percentage errors for coefficient years | | | | |
|-----------------|---------|-----------------------------------------|---------|---------|---------|---------|
| | | 2009-10 | 2008-10 | 2007-10 | 2006-10 | 2005-10 |
| Financial Years | 2005-06 | -109.84% | 116.04% | 111.88% | 86.26% | 25.67% |
| | 2006-07 | -81.26% | 7.05% | 5.70% | -0.63% | -15.79% |
| | 2007-08 | -59.85% | 0.97% | 0.34% | -0.17% | -2.91% |
| | 2008-09 | -42.61% | -1.20% | -1.54% | -0.60% | -1.61% |
| | 2009-10 | 0.00% | 1.39% | 1.40% | 1.59% | 7.67% |

Table 20: Ancillary Services Response Cost Model Back-testing

5 year regression back test

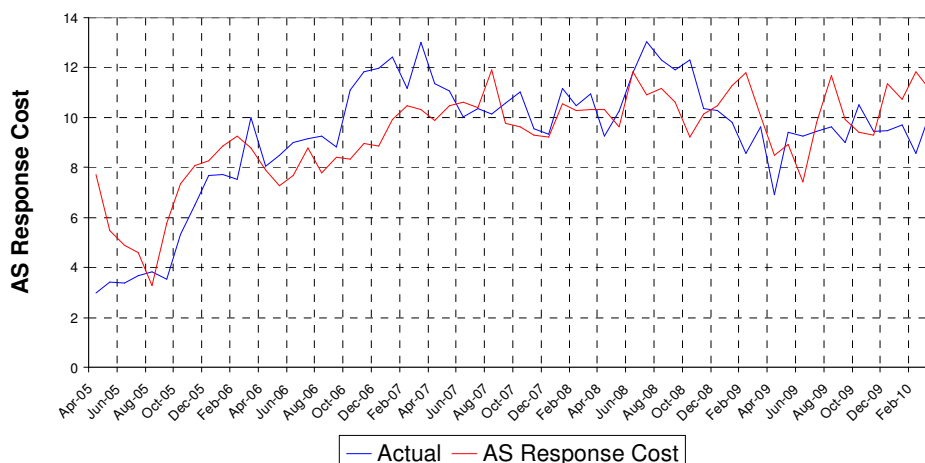

Figure 15: Ancillary Services Response cost back testing graph

Response BM Offer Volume

The coefficients for the Response BM Offer volume can be found in Table 21 below:

| Variables | Coefficients | Std. Error | t value |
|-----------------------|---------------|--------------|----------|
| (Intercept) | 3189000.00000 | 545800.00000 | 5.84400 |
| SUMMER * AVG_NUKE | 31.81000 | 7.19800 | 4.42000 |
| SUMMER * AVG_HEADROOM | -85.17000 | 21.43000 | -3.97300 |
| LOG_DEMAND | -307500.00000 | 52130.00000 | -5.90000 |
| AVG_NUKE | 14.14000 | 3.00700 | 4.70400 |
| AVG_WIND | 82.60000 | 31.97000 | 2.58300 |

Section 7 Appendices

| | | | |
|-----------------------|----------|----------|---------|
| NIV_MWH | 71.15000 | 27.85000 | 2.55400 |
| WINTER * AVG_HEADROOM | 6.87100 | 3.35200 | 2.05000 |
| Adjusted R-Squared | 0.7428 | | |

Table 21: Response BM Offer Volume regression coefficients

The back testing results of the Response BM Offer volume regression can be seen below in Table 22 and Figure 16.

| | | Percentage errors for coefficient years | | | | |
|-----------------|---------|-----------------------------------------|---------|---------|---------|---------|
| | | 2009-10 | 2008-10 | 2007-10 | 2006-10 | 2005-10 |
| Financial Years | 2005-06 | 17.00% | -26.20% | -5.20% | 5.50% | -0.88% |
| | 2006-07 | 120.00% | -37.60% | -17.60% | -7.50% | -9.60% |
| | 2007-08 | 310.00% | -40.60% | -7.50% | 2.80% | 3.82% |
| | 2008-09 | 380.00% | 3.30% | 18.30% | 29.90% | 35.90% |
| | 2009-10 | 0.00% | -0.90% | -2.10% | -5.10% | -5.38% |

Table 22: Response BM Offer Volume regression back testing

5 year regression back test

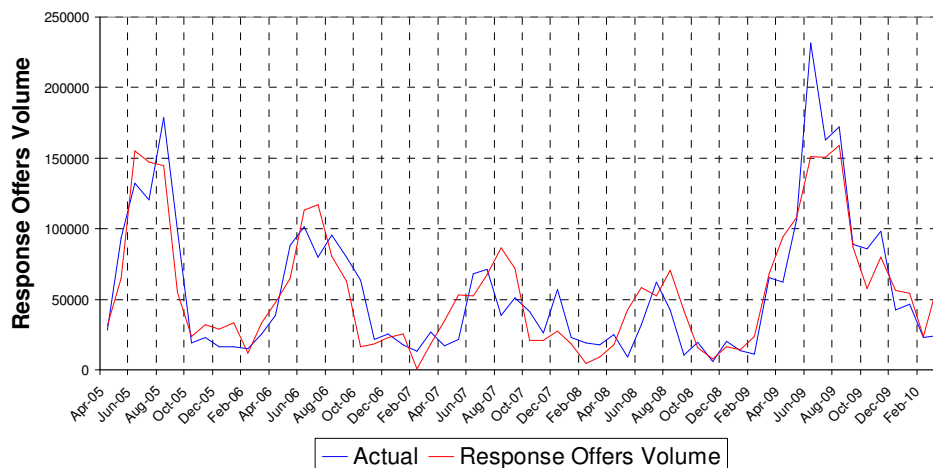

Figure 16: Response BM Offer Volume back testing

Response BM Offer Price

The coefficients for the Response BM Offer Price are set out in Table 23 below.

| Variables | coefficients | Std. Error | t value |
|--------------------|--------------|------------|---------|
| (Intercept) | 1.00200 | 3.09100 | 0.32400 |
| AVG_SPNIRP | 0.34820 | 0.05600 | 6.21700 |
| RESPONSE_O_MWH | 0.00007 | 0.00002 | 3.43300 |
| Adjusted R-Squared | 0.3938 | | |

Table 23: Response BM Offer Price regression coefficients

The back testing of the above Response BM Offer price regression can be found in Figure 17 and Table 24 below:

Section 7 Appendices

| | | Percentage errors for coefficient years | | | | |
|-----------------|---------|-----------------------------------------|---------|---------|---------|---------|
| | | 2009-10 | 2008-10 | 2007-10 | 2006-10 | 2005-10 |
| Financial Years | 2005-06 | -57.00% | -10.20% | -19.10% | -12.70% | -10.80% |
| | 2006-07 | -1.20% | -17.10% | -32.20% | -20.40% | -18.80% |
| | 2007-08 | 24.00% | 56.60% | 29.60% | 49.10% | 56.10% |
| | 2008-09 | -160.00% | -5.30% | -9.20% | -8.80% | -2.30% |
| | 2009-10 | 0.00% | 7.60% | -3.20% | 6.00% | 4.30% |

Table 24: Response BM Offer Price regression back testing

5 year regression back test

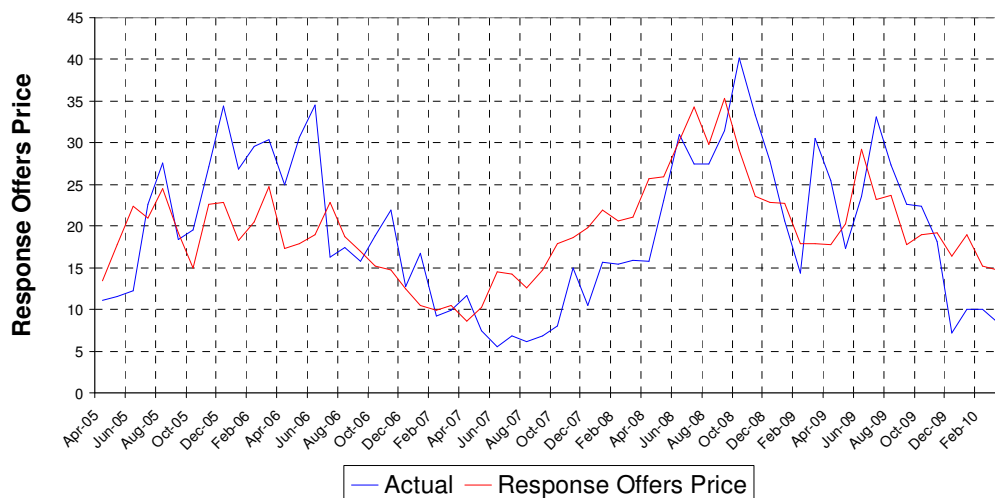

Figure 17: Response BM Offer Price regression back testing

Response BM Offer Cost

Table 25 and the graph in Figure 18 below show the back testing of the BM Response Offer Cost model (i.e. the result of both the BM Response Offer volume and BM Response Offer price models as set out above).

| | | Percentage errors for coefficient years | | | | |
|-----------------|---------|-----------------------------------------|---------|---------|---------|---------|
| | | 2009-10 | 2008-10 | 2007-10 | 2006-10 | 2005-10 |
| Financial Years | 2005-06 | -5.15% | -15.15% | -2.45% | 12.03% | 2.67% |
| | 2006-07 | 85.33% | -42.38% | -36.55% | -22.97% | -24.25% |
| | 2007-08 | 789.22% | -3.11% | 24.71% | 62.45% | 66.26% |
| | 2008-09 | -459.86% | -0.22% | 9.56% | 19.35% | 33.70% |
| | 2009-10 | -0.53% | -1.03% | -10.15% | -7.39% | -11.41% |

Table 25: Response BM Offers cost model back-testing

5 year regression back test

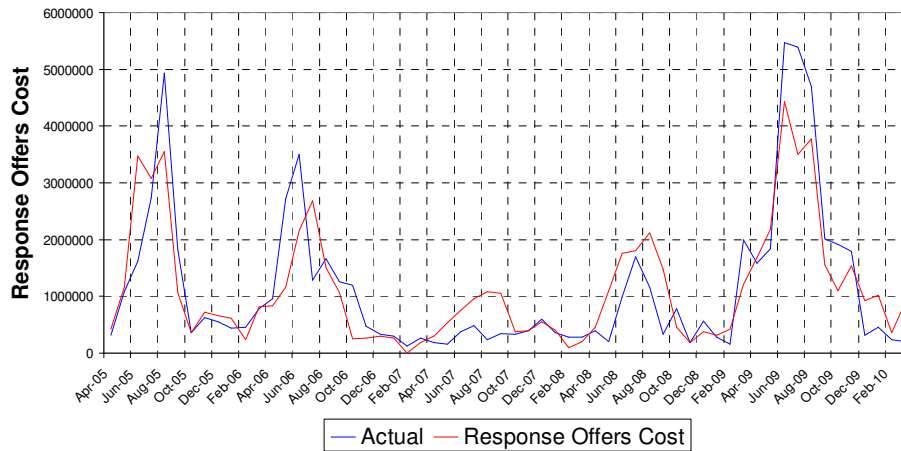

Figure 18: Response BM Offers cost back testing

Response BM Bid Volume

The coefficients for the Response BM Bid Volume are set out in Table 26 below:

| Variables | Coefficients | Std. Error | t value |
|-----------------------|--------------|------------|---------|
| (Intercept) | 522923.51 | 53024.71 | 9.862 |
| NIV_MWH | -291.95 | 59.42 | -4.914 |
| TREND | -2883.72 | 442.54 | -6.516 |
| AVG_HEADROOM | -86.03 | 17.37 | -4.954 |
| WINTER * AVG_HEADROOM | 20.54 | 6.35 | 3.234 |
| Adjusted R-Squared | 0.6336 | | |

Table 26: Response BM Bid Volume regression coefficients

The back testing of the Response BM bid volume regression can be found in Table 27 and Figure 19 below:

| | | Percentage errors for coefficient years | | | | |
|-----------------|---------|-----------------------------------------|---------|---------|---------|---------|
| | | 2009-10 | 2008-10 | 2007-10 | 2006-10 | 2005-10 |
| Financial Years | 2005-06 | -140.00% | 6.10% | -11.14% | -13.33% | -4.90% |
| | 2006-07 | -160.00% | 19.50% | 1.63% | 0.63% | 6.84% |
| | 2007-08 | -130.00% | 18.50% | 1.79% | 0.96% | 4.10% |
| | 2008-09 | -8.10% | 1.50% | -0.28% | -1.15% | 0.76% |
| | 2009-10 | 0.00% | -2.20% | -1.56% | -0.19% | -5.75% |

Table 27: Response BM Bid Volume regression back testing

5 year regression back test

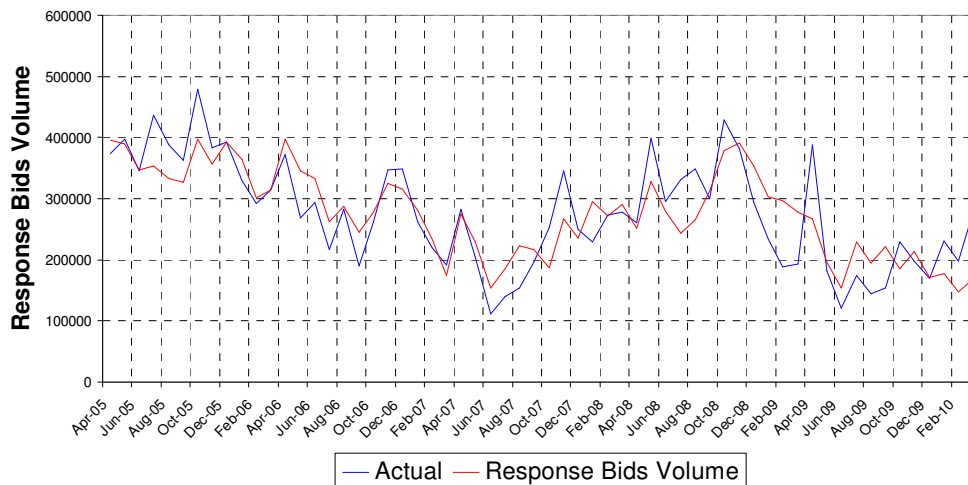

Figure 19: Response BM Bid volume regression back testing

Response BM Bid Price

The coefficients for the Response BM Bid Price are set out in Table 28 below:

| Variables | Coefficients | Std. Error | t value |
|--------------------|--------------|------------|---------|
| (Intercept) | -3.12798 | 1.34081 | -2.333 |
| AVG_BM_PRICE | 0.34281 | 0.03076 | 11.144 |
| Adjusted R-Squared | 0.6762 | | |

Table 28: Response BM Bid Price regression coefficients

The back testing of the Response BM bid price regression can be found in Table 29 and Figure 20 below:

| | | Percentage errors for coefficient years | | | | |
|-----------------|---------|-----------------------------------------|---------|---------|---------|---------|
| | | 2009-10 | 2008-10 | 2007-10 | 2006-10 | 2005-10 |
| Financial Years | 2005-06 | 6.20% | 2.00% | 8.00% | 5.10% | 4.20% |
| | 2006-07 | 35.00% | -1.40% | 18.50% | 12.40% | 9.10% |
| | 2007-08 | -0.40% | -13.20% | -4.10% | -7.50% | -9.00% |
| | 2008-09 | -9.40% | 9.40% | 5.70% | 5.00% | 5.60% |
| | 2009-10 | 0.00% | -15.70% | -5.40% | -9.00% | -10.70% |

Table 29: Response BM Bid price regression back testing

5 year regression back test

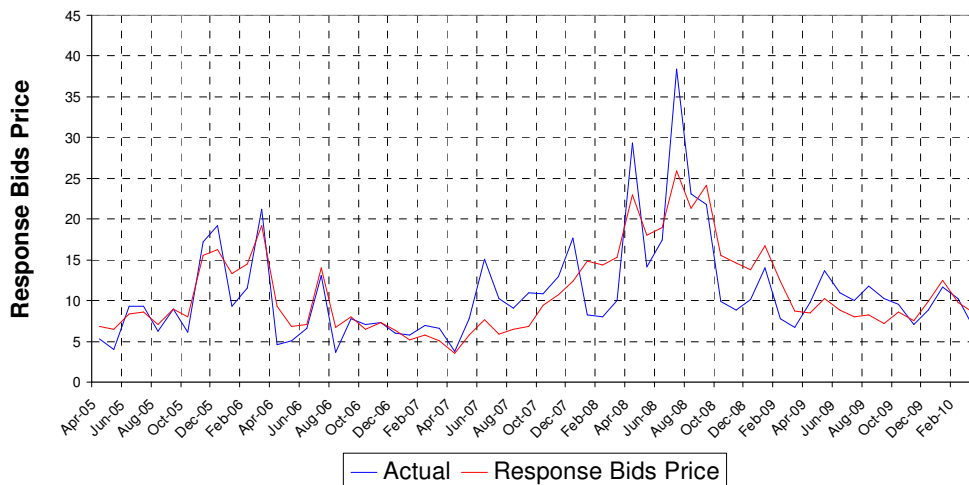

Figure 20: BM Response Bid price regression back testing

Response BM Bid Cost

Table 30 and the graph in Figure 21 below show the back testing of the BM Response Bid Cost model (i.e. the result of the multiplication of the BM Response Bid volume with the BM Response Bid price regressions as set out above).

| | | Percentage errors for coefficient years | | | | |
|-----------------|---------|-----------------------------------------|---------|---------|---------|---------|
| | | 2009-10 | 2008-10 | 2007-10 | 2006-10 | 2005-10 |
| Financial Years | 2005-06 | -145.68% | 8.96% | -2.76% | -7.48% | 0.22% |
| | 2006-07 | -178.73% | 23.76% | 25.57% | 17.64% | 21.76% |
| | 2007-08 | -117.24% | 6.42% | 2.56% | -1.27% | 0.00% |
| | 2008-09 | -20.94% | 8.35% | 1.91% | 0.00% | 2.74% |
| | 2009-10 | 1.62% | -17.02% | -6.05% | -8.36% | -15.27% |

Table 30: BM Response Bid Cost model back testing

5 year regression back test

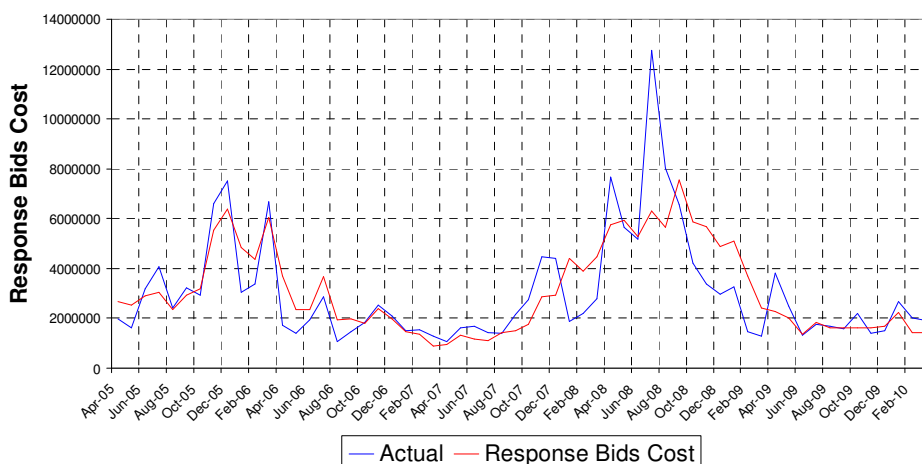

Figure 21: Response BM Bid cost back testing

Frequency Response Cost

Section 7 Appendices

The total forecast cost for Frequency Response is achieved by the addition of the above three elements (response BM offer cost, response BM bid cost and Ancillary Services response cost). The back testing of the overall frequency response model is shown in Figure 22 below:

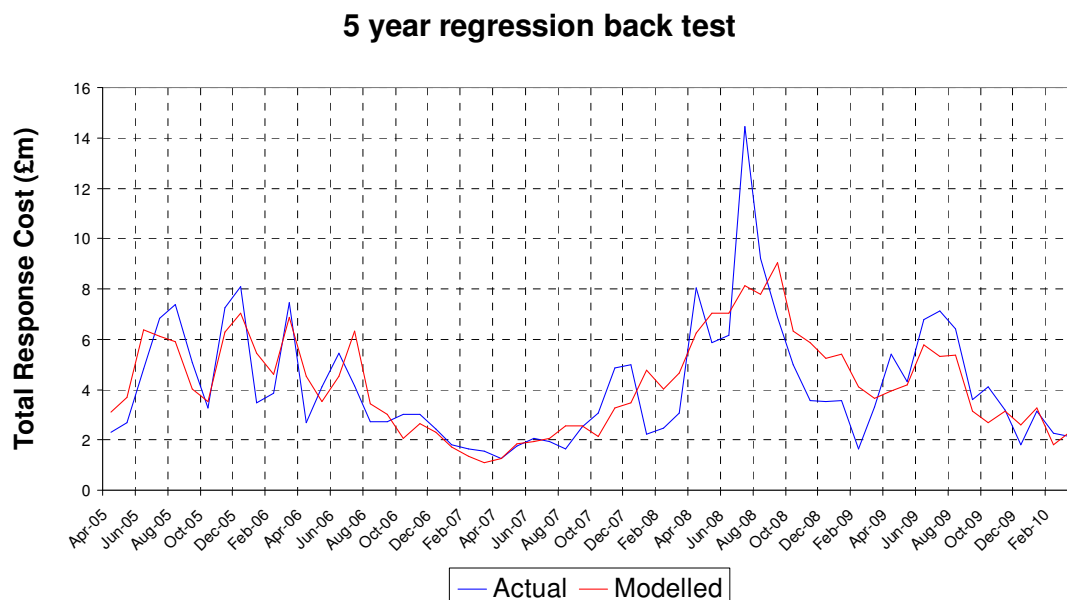

Figure 22: Frequency Response Cost model back testing

Footroom Model Coefficients and Back-testing

Footroom Bid Volume

The footroom bid volume regression coefficients can be found in Table 31 below:

| Variables | Coefficients | Std. Error | t value |
|--------------------|---------------|--------------|----------|
| (Intercept) | 5009000.00000 | 854400.00000 | 5.86300 |
| LOG_DEMAND | -493600.00000 | 81360.00000 | -6.06800 |
| AVG_NUKE | 31.45000 | 5.27200 | 5.96400 |
| AVG_WIND | 160.20000 | 67.33000 | 2.37900 |
| SUMMER * AVG_WIND | 365.60000 | 118.20000 | 3.09400 |
| WINTER * AVG_WIND | 167.60000 | 73.06000 | 2.29400 |
| Adjusted R-Squared | 0.6551 | | |

Table 31: Footroom bid volume regression coefficients

The back testing of the Footroom bid volume regression can be found below in Table 32 and Figure 23 below.

| | | Percentage errors for coefficient years | | | | |
|-----------------|---------|-----------------------------------------|---------|---------|---------|---------|
| | | 2009-10 | 2008-10 | 2007-10 | 2006-10 | 2005-10 |
| Financial Years | 2005-06 | 270.00% | 122.20% | 42.50% | 73.70% | 26.00% |
| | 2006-07 | 110.00% | 3.40% | -26.00% | -13.20% | -28.30% |
| | 2007-08 | 290.00% | 36.50% | 5.70% | 28.10% | 14.30% |
| | 2008-09 | 200.00% | 16.90% | 29.30% | 35.10% | 47.70% |

| | | | | | |
|---------|-------|--------|--------|--------|--------|
| 2009-10 | 0.00% | -4.20% | -8.50% | -8.10% | -9.40% |
|---------|-------|--------|--------|--------|--------|

Table 32: Footroom bid volume regression back testing

5 year regression back test

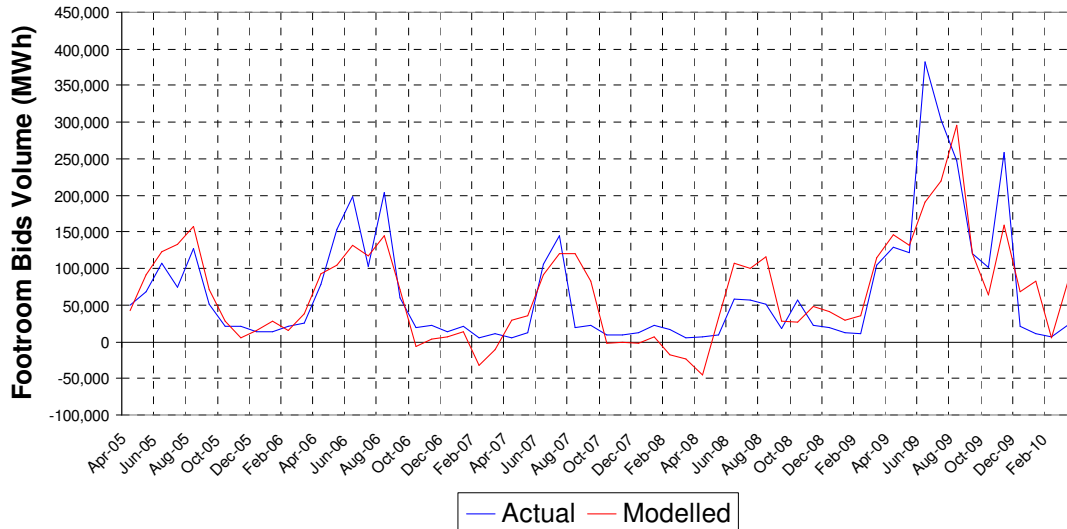

Figure 23: Footroom bid volume regression back testing

Footroom Bid Cost

The back testing for the Footroom bid cost model can be found in Table 33 and Figure 24 below. The forecast Footroom Bid cost is achieved by the multiplication of the outcome of the Footroom bid volume regression as set out above and the forecast (ex-ante) price for footroom as set out in Section 3.

| | | Percentage errors for coefficient years | | | | |
|-----------------|---------|-----------------------------------------|---------|---------|---------|---------|
| | | 2009-10 | 2008-10 | 2007-10 | 2006-10 | 2005-10 |
| Financial Years | 2005-06 | 533.19% | 283.82% | 146.18% | 200.02% | 117.75% |
| | 2006-07 | 238.49% | 68.79% | 20.76% | 41.62% | 17.02% |
| | 2007-08 | 417.55% | 81.22% | 40.31% | 70.02% | 51.75% |
| | 2008-09 | 281.54% | 50.21% | 66.13% | 73.53% | 89.74% |
| | 2009-10 | 0.00% | -4.19% | -8.53% | -8.14% | -9.40% |

Table 33: Footroom Bid Cost model back testing

5 year regression back test

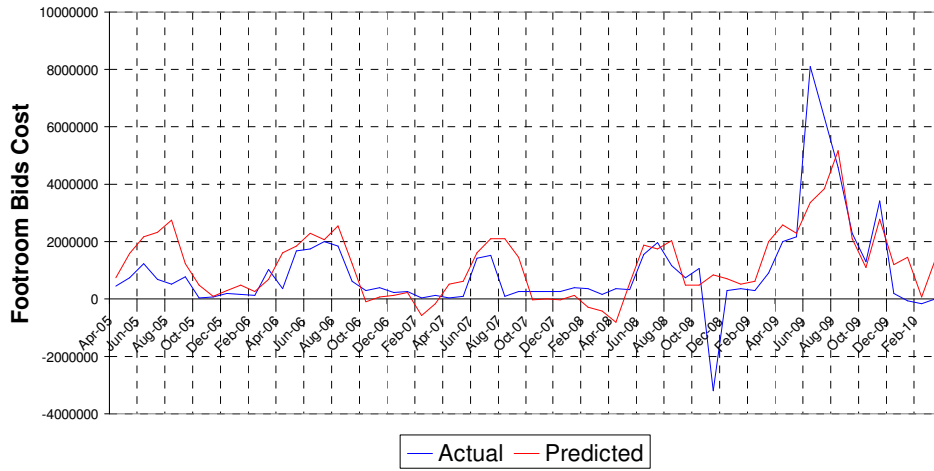

Figure 24: Footroom Bid Cost model back testing

2. Appendix B: Treatment of Model Inputs

| Forecasting drivers of Generation Availability | |
|------------------------------------------------|--------------------------------------------------------------------------------------------------------------------------------------------------------------------------------------------------------------------------------------------------------------------------------------------------------------------------------------------------------------------------------------------------------------------------------------------------------------------------------------------------------------------------------------------------------------------------------------------------------------------------------------------------------------------------------------------------------------------------------------------------------------------------------------------------------------------------------------------------------------------------------------------------------------------------------------------------------------------------------------------------------------------------------------------------------------------------------------------------------------------------------------------------------------------------------------------------------------------------------------------------------------------------------------------------------------------------------------------------------------------------------------------------------------------------------------------------------------------------------------------------------------------------------------------------------------------------------------------------------------------------------------------------------------------------------------------------------------------------------------------------------------------------------------------------------------------------------------------------------------------|
| Measure | Detail |
| Is data readily available? | <p>Planned outage data: YES Generator availability is notified to National Grid under the provisions of OC2. Hence the data itself, once submitted, is readily available. Data quantity/quality decreases as the lead-time of the data increases.</p> <p>Unplanned outage data: YES (though at short notice) Unplanned outages are notified to National Grid through re-declarations of the 'Maximum Export Limit' (MEL) parameter in the BM, and represent generators' contribution to NIV until the lost output is replaced. If they persist, they would become visible through OC2 data submissions.</p> <p>Drivers behind data:</p> <p>Maintenance Drivers and Contractor Availability: NO National Grid has no knowledge of the maintenance policies applicable to generation plant except to the extent that they depend upon factors such as running hours, number of starts, etc.</p> <p>Wholesale Power Prices and Fuel Prices: YES Data relating to historic fuel prices and wholesale power prices are readily available. Forward price curves also exist for fuel prices and wholesale power prices, although such forward curves may not be reflective of the prices at the time of planned outages.</p> <p>Plant efficiency: NO High-level information regarding generic plant efficiency factors is available; however specific information relating to individual generators and their various operating configurations tends to be known only by the owners of the plant.</p> <p>Faults: YES National Grid can estimate data regarding faults on generating plant from MEL submissions, based on assumptions.</p> <p>LCPD/Emissions: YES Data relating to the Large Combustion Plant Directive/emissions are available on the Environment Agency website.</p> |

Section 7 Appendices

| Forecasting drivers of Generation Availability | |
|------------------------------------------------|-----------------------------------------------------------------------------------------------------------------------------------------------------------------------------------------------------------------------------------------------------------------------------------------------------------------------------------------------------------------------------------------------------------------------------------------------------------------------------------------------------------------------------------------------------------------------------------------------------------------------------------------------------------------------------------------------------------------------------------------------------------------------------------------------------------------------------------------------------------------------------------------------------------------------------------------------------------------------------------------------------------------------------------------------------------------------------------------------------------------------------------------------------------------------------------------------------------------------------------------|
| Measure | Detail |
| Volatility of drivers | <p>Maintenance Drivers and Contractor Availability: Varies with lead time Low (up to e.g. 4 weeks) – increasing to HIGH (beyond 6 months) Maintenance drivers tend to be based on policy, hence should be stable. Contractor availability can change, however, and National Grid has no sight of this.</p> <p>Wholesale Power Prices and Fuel Prices: HIGH Whilst National Grid is able to monitor movements in market fundamentals such as fuel price and wholesale price, any decision by a generator to mothball or regime plant is largely unforecastable.</p> <p>Plant efficiency: LOW Plant efficiency would only change if plant characteristics change.</p> <p>Faults: HIGH Faults are random in nature, hence they, and their contribution to NIV, are highly volatile and cannot be forecast in a meaningful sense.</p> <p>LCPD/Emissions: MEDIUM Restrictions on running hours lead generators to target high-reward periods in which to generate. Hence these periods are linked to fuel prices and wholesale power prices, but could reasonably be expected to coincide with winter periods.</p> |
| Applicability of historic data trend analysis | <p>OC2 data: NO Because of its drivers, OC2 data is unique to a particular time period and, other than the fact that outages tend to be taken over the lower-demand summer period, show no real trend.</p> <p>MEL data: NO The random nature of faults makes it difficult to use past history as an indication of when faults might occur.</p> |
| Conclusion: | <p>Forecast confidence for drivers behind OC2 data = Low to medium Forecast confidence for drivers behind short-term faults = None</p> |

Table 34: Forecasting drivers of Generation Availability

Section 7 Appendices

| Ability to control drivers of Generation Availability | | |
|-------------------------------------------------------|---------------------------------------------------------------------------------------------------------------------------------------------------------------------------------------------------------------------------------------------------------------------------------------------------------------------------------------------------------------------------------------------------------------------------------------------------------------------------------------------------------------------------------------------------------------------------------------------------------------------------------------------------------------------------------------------------------------------------------------------------------------------------------------------------------------|--------------------------------------------------------------------------------------------------------------------------------------------------------------------------------------------------------------------------|
| Tool | Extent of National Grid control | What does an incentive drive us to do? |
| Balancing Mechanism (BM) | <p>The BM can only be used to change output levels of generators that are already running or can be made to run in BM timescales. The BM is not a means by which National Grid can make generation available.</p> <p>Ability to influence generator availability via the BM: None</p> | N/A |
| Trades | <p>National Grid has limited ability to use trades to influence generator availability. National Grid tends to trade within-day/day-ahead for general energy balancing; and may trade up to two weeks ahead for constraint management purposes (having taken a view on generator running and outage certainty), whereas generator outages will generally be finalised before then.</p> <p>Where trading is possible, National Grid would require the ability to enter into BM Unit-specific trades under its standard Grid Trade Master Agreement (GTMA) provisions. Also, the less competition exists in service provision, the more difficult it is for National Grid to be able to influence the price it would have to pay.</p> <p>Ability to influence generator availability via trades: Low</p> | <p>Develop/enhance trading strategies; Extend the availability of GTMA Schedule 7A to enable BM Unit-specific trades from a wider pool of counter-parties</p> |
| Balancing Services contracts | <p>Balancing Services contracts are perhaps the main tool by which National Grid is able to influence generation availability, as they provide a means by which we can discuss and agree our requirements with generators ahead of time, at which point it may be possible to influence generation outage dates before details such as contractor availability have been finalised, or by funding changes to contractor availability.</p> <p>As with trades, a lack of competition in service provision can make it difficult for National Grid to influence the price it would have to pay, although the longer lead-times may allow a wider range of options to be explored.</p> <p>Ability to influence generator availability via contracts: Medium</p> | <p>Develop existing/new ancillary service mechanisms to influence generator availability; Facilitate provision of such services by potential service providers; Increase pool of available service providers</p> |
| Transmission system planning/operation | N/A | |
| Changes to | N/A | |

Section 7 Appendices

| Ability to control drivers of Generation Availability | | |
|-------------------------------------------------------|---------------------------------------------------------------------------------------------------------------------------------------------------------------------------------------------------------------------------------------------------------------------------------------------------------------------------------------------------------------------------------------------------------------------------------------------------------------------------------------------------------------------------------------------------------------------------------------------------------------------------------------------------------------------------------------------------------------------------------|-------------------------------------------------------------------------------------------------------------------------------------------------------------|
| Tool | Extent of National Grid control | What does an incentive drive us to do? |
| operating policy | | |
| Changes to industry codes | <p>The code change route could be used to propose changes to outage co-ordination processes with the aim of ensuring their continued efficiency. However it is important to note the context within which the code processes are set and it is unlikely that, for example, firm obligations to co-ordinate generation and transmission outages; and the imposition incentives on generators in the form of penalties where co-ordination is not maintained; could be introduced via this route. Rather, they might take the more general form of enhanced licence obligations to minimise constraint costs through efficient co-ordination.</p> <p>Ability to influence generator availability via code changes: Low</p> | Investigate how increased co-ordination and efficiency between code parties might be possible and what the benefit for the outage planning process might be |
| Information provision | <p>National Grid publishes a range of information to the industry through its Seven Year Statement, its own website and via submission to the Balancing Mechanism Reporting Agent (BMRA). Some of this information may influence generator availability, for example demand forecasts and Short Term Operating Reserve requirements.</p> <p>Ability to influence generator availability via information provision: Low</p> | Investigate how increased availability of information might lead to more effective functioning of the market with regard to system operator actions |
| Conclusion: | Degree of control by system operator = | Long term generator availability: Low to medium ; Short-term availability (including generation contribution to NIV): None |

Table 35: Ability to control drivers of Generation Availability

Section 7 Appendices

| Forecasting drivers of Generation Running | |
|-------------------------------------------|--------------------------------------------------------------------------------------------------------------------------------------------------------------------------------------------------------------------------------------------------------------------------------------------------------------------------------------------------------------------------------------------------------------------------------------------------------------------------------------------------------------------------------------------------------------------------------------------------------------------------------------------------------------------------------------------------------------------------------------------------------------------------------------------------------------------------------------------------------------------------------------------------------------------------------------------------------------------------------------------------------------------------------------------------------------------------------------------------------------------------------------------------------------------------------------------------------------------------------------------------------------------------------------------------------------------------------------------------------------------------------------------------------------------------------------------------------------------------------------------------------------------------------------------------------------------------------------------------------------------------------------------------------------------------------------------------------------------------------------------------------------------------------------------------------------------------------------------------------------------------------------------------------------------------------------------------------------------------------------------------------------------------------------|
| Measure | Detail |
| Is data readily available? | <p>Generation Availability: YES Generator availability data is available via OC2 and MEL submissions, subject to increasing uncertainty as lead time increases (as described earlier).</p> <p>Wholesale Power Prices and Fuel Prices: YES Data relating to historic fuel prices and wholesale power prices are readily available. Forward price curves also exist for fuel prices and wholesale power prices, although such forward curves may not be reflective of the prices at the time of planned outages.</p> <p>Plant efficiency: NO Specific information relating to individual generators and their various operating configurations tends to be known only by the owners of the plant. However, it may be possible to collate generic plant efficiency factors based on age, technology and fuel type.</p> <p>Generator Risk Management Data: NO Information relating to generators' approach to managing portfolio risk is not readily available. Attempts can be made to derive behaviours from available data sources; however it is difficult to derive robust data.</p> <p>Renewable Generation Running: YES Renewable generation can be monitored by National Grid where suitable metering is in place.</p> <p>SQSS Requirements: YES The SQSS specifies criteria within which the transmission system must be operated. These criteria drive the need to procure frequency response and energy reserves to manage the risks associated with generation running (for example keeping system frequency within prescribed limits following the largest credible/ allowed generation loss).</p> <p>BM Pricing: YES Data regarding generator bid-offer prices is readily available.</p> <p>Drivers behind data:</p> <p>Fuel Market Fundamentals/'Take or Pay' Contracts: NO Whilst it may be possible to form a view, detailed information regarding the drivers behind fuel prices is not available to National Grid.</p> |

Section 7 Appendices

| Forecasting drivers of Generation Running | |
|-------------------------------------------|--------------------------------------------------------------------------------------------------------------------------------------------------------------------------------------------------------------------------------------------------------------------------------------------------------------------------------------------------------------------------------------------------------------------------------------------------------------------------------------------------------------------------------------------------------------------------------------------------------------------------------------------------------------------------------------------------------------------------------------------------------------------------------------------------------------------------------------------------------------------------------------------------------------------------------------------------------------------------------------------------------------------------------------------------------------------------------------------------------------------------------------------------------------------------------------------------------------------------------------------------------------------------------------------------------------------------------------------------------------------------------------------------------------------------------------------------------------------------------------------------------------------------------------------------------------------------------------------------------------------------------------------------------------------------------------------------------------------------------------------------------------------------------------------------------------------------------------------------------------------------------------------------------------------------|
| Measure | Detail |
| | <p>Participant Trading Activity: NO Detailed information regarding the drivers behind participant trading activity is not available to National Grid.</p> <p>Plant characteristics: NO Whilst it may be possible to form a view, detailed information regarding the characteristics of generating plant that drive fuel efficiency is not available to National Grid.</p> <p>Need for Free Headroom: NO Portfolio risk management methods are not visible to National Grid, hence it is not possible to obtain data regarding the level of free headroom that generators are likely to hold.</p> <p>Fuel Stocks: NO Detailed information regarding participants' fuel stocks is not available to National Grid.</p> <p>LCPD/Emissions: YES Data relating to the Large Combustion Plant Directive/emissions are available on the Environment Agency website.</p> <p>'Opportunistic' behaviour: NO Whilst it may be possible to identify behaviour that might look as though it represents opportunistic behaviour on the part of generators (for example the exploitation of transmission constraints) it is extremely difficult to be certain about such behaviours. Certainly, no data exists to allow it to be modelled.</p> <p>Weather: YES (developing for wind speed data) The weather is a key factor in determining renewable generation running – particularly for wind and run-of-river hydro. National Grid has a range of weather data at its disposal, and is working to develop its capture of wind speed data at wind farm sites.</p> <p>Response/Reserve Requirements/largest generation loss: YES Data for frequency response/reserve requirements and the largest generation loss (as derived from SQSS criteria) are readily available to National Grid.</p> <p>Wholesale power price mark-ups: YES</p> |

Section 7 Appendices

| Forecasting drivers of Generation Running | |
|-------------------------------------------|-------------------------------------------------------------------------------------------------------------------------------------------------------------------------------------------------------------------------------------------------------------------------------------------------------------------------------------------------------------------------------------------------------------------------------------------------------------------------------------------------------------------------------------------------------------------------------------------------------------------------------------------------------------------------------------------------------------------------------------------------------------------------------------------------------------------------------------------------------------------------------------------------------------------------------------------------------------------------------------------------------------------------------------------------------------------------------------------------------------------------------------------------------------------------------------------------------------------------------------------------------------------------------------------------------------------------------------------------------------------------------------------------------------------------------------------------------------------------------------------------------------------------------------------------------------------------------------------------------------------------------------------------------------------------------------------------------------------------------------------------------------------------------------------------------------------------------------------------------------------------------------------|
| Measure | Detail |
| | Bid-offer data can be compared against wholesale electricity prices to determine the level of mark-up. |
| Volatility of drivers | <p>Fuel Market Fundamentals/'Take or Pay' Contracts: HIGH Fuel markets can exhibit significant volatility through the interaction between supply and demand.</p> <p>Participant Trading Activity: MEDIUM Volatility associated with individuals' trading activity depends to an extent on whether they have contract cover through vertical integration.</p> <p>Plant characteristics: LOW Plant characteristics would only tend to change through replacement of equipment.</p> <p>Need for Free Headroom: HIGH The need for generators to hold free headroom depends on the physical ability of their plant to robustly meet their contract obligations and their desire to avoid imbalance cash-out if their plant fails to deliver. Accordingly, it is linked to the risk that generating plant might develop a fault and the perceived risk of incurring imbalance cash-out charges, both of which can be highly volatile).</p> <p>Fuel Stocks: MEDIUM The requirement and ability to hold fuel stocks depends on expected generation running, which is a function of market fundamentals.</p> <p>LCPD/Emissions: MEDIUM Restrictions on running hours lead generators to target high-reward periods in which to generate. Hence these periods are linked to fuel prices and wholesale power prices, but could reasonably be expected to coincide with winter periods.</p> <p>'Opportunistic' behaviour: MEDIUM 'Opportunistic' behaviour may be linked to a particular transmission outage; and may become visible to market participants. This in turn may temper its impact.</p> <p>Weather: Varies with lead time Low (within day) – HIGH (beyond 1 day) Weather conditions can be highly variable. Wind speed in particular is difficult to forecast beyond a few hours.</p> |

Section 7 Appendices

| Forecasting drivers of Generation Running | |
|-----------------------------------------------|----------------------------------------------------------------------------------------------------------------------------------------------------------------------------------------------------------------------------------------------------------------------------------------------------------------------------------------------------------------------------------------------------------------------------------------------------------------------------------------------------------------------------------------------------------------------------------------------------------------------------------------------------------------------------------------------------------------------------------------------------------------------------------------------------------------------------------------------------------------------------------------------------------------------------------------------------------------------------------------------------------------------------------------------------------------------------------------------------------------------------------------------------------------------------------------------------------------------------------------------------------------------------------------------------------------------------------------------------------------------------------------------------------------------------------------------------|
| Measure | Detail |
| | <p>Response/Reserve Requirements and largest generation loss: LOW Requirements for frequency response/reserve and the largest generation loss, being based on SQSS criteria, tend to change infrequently.</p> <p>Wholesale power price mark-ups: HIGH The drivers behind the extent to which generators apply a mark-up to wholesale power prices when setting bid-offer prices (for example changing fuel prices, locational price exploration) and the fact that bid-offer prices can change half hourly contribute to the potential for them to exhibit significant volatility.</p> |
| Applicability of historic data trend analysis | <p>Generation Availability: NO As discussed in the previous section, generator availability is a function of the need to take outages which, other than the fact that planned outages tend to be taken over the lower-demand summer period, show no real trend.</p> <p>Wholesale Power Prices and Fuel Prices: NO Wholesale power prices and fuel prices are a function of the interactions between market participants in relation to bulk energy trading. Whilst trends may be observable in past behaviour it is not often the case that they provide a robust indicator of future pricing.</p> <p>Plant efficiency: YES In the absence of equipment changes, plant efficiency should remain reasonably constant.</p> <p>Generator Risk Management Data: NO Whilst generators may adopt reasonably consistent policies for risk management, the way they manifest themselves and the difficulties in obtaining data on generator risk management make trend analysis difficult.</p> <p>Renewable Generation Running: NO At the moment, insufficient data/evidence exists for trend analysis to help with forecasting renewable generation running. The situation may change as more data becomes available and forecasting techniques develop.</p> <p>SQSS Requirements: YES SQSS criteria tend to change infrequently.</p> <p>Wholesale power price mark-ups: YES</p> |

Section 7 Appendices

| Forecasting drivers of Generation Running | |
|-------------------------------------------|----------------------------------------------------------------------------------------------------------------------------------------------------------------------------------------------------------------------------------------------------------------------------------|
| Measure | Detail |
| | Whilst trends in wholesale power prices might not be a reliable indicator of future price levels, the extent to which bid-offer prices are set relative to the wholesale price, absent any locational/opportunistic behaviour, is more likely to be suitable for trend analysis. |
| Conclusion: | Forecast confidence = Low to medium |

Table 36: Forecasting drivers of Generation Running

Section 7 Appendices

| Ability to control drivers of Generator Running | | |
|--------------------------------------------------------|-----------------------------------------------------------------------------------------------------------------------------------------------------------------------------------------------------------------------------------------------------------------------------------------------------------------------------------------------------------------------------------------------------------------------------------------------------------------------------------------------------------------------------------------------------------------------------------------------------------------------------------------------------------------------------------------------------------------------------------------------------------------------------------------------------------------------------------------------------------------------------------------------------------------------------------------------------------------|-----------------------------------------------------------------------------------------------------------------------------------------------------------------------------------------------------------------------------------------------------------------------------------------------------------------------------------------------------------------------------------------------------------------------------------------------|
| Tool | Extent of National Grid control | What does an incentive drive us to do? |
| Balancing Mechanism (BM) | <p>The BM can only be used in the short-term to change output levels of generators that are already running or can be made to run in BM timescales. This makes it useful for dealing with short-term plant loss or transmission issues which a large pool of potential providers can alleviate. It is not possible to influence longer-term generation running via the BM.</p> <p>Ability to influence generator running via the BM: Low</p> | Ensure efficient trade-off between expected prices/volumes available in the BM with options for trading/contracting pre-gate closure |
| Trades | <p>National Grid has a limited ability to use trades to influence generator running. National Grid is generally able to trade up to two weeks ahead, which gives some scope to manage running profiles at a BM Unit level, subject to suitable GTMA terms (Schedule 7A) being in place. However they do not allow for additional flexibility (e.g. management of offer/bid volumes/prices in the BM).</p> <p>Low levels of competition in service provision make it difficult for National Grid to influence the price it would have to pay.</p> <p>National Grid can also seek to obtain additional energy via Pre-Gate Closure BM Unit Transactions (PGBTs). These are based on a more open procurement process (offers are invited from participants for energy provision and the most suitable price/volume combination chosen) but are restricted to use in prompt timescales.</p> <p>Ability to influence generator running via trades: Medium</p> | <p>Develop/enhance trading strategies;</p> <p>Attain prices better than those forecast to be available in the BM (and manage associated half-hourly price risk);</p> <p>Extend the availability of GTMA Schedule 7A to enable BM Unit-specific trades from a wider pool of counter-parties</p> |
| Balancing Services contracts | <p>Balancing Services contracts provide National Grid with the ability to specify and procure a range of Balancing Services through the timescales.</p> <p>National Grid consults widely with the industry when developing and enhancing the design and operation of Balancing Services but has a high degree of control over service design.</p> <p>National Grid uses Balancing Services contracts to satisfy its frequency response requirement and that level of reserve over and above what is provided through market operation.</p> | <p>Develop/enhance strategies for determining required constraint contract volumes;</p> <p>Develop existing/new ancillary service mechanisms to influence generator running;</p> <p>Facilitate provision of such services by potential service providers;</p> <p>Attain prices better than those forecast to be available in the BM or via trades (and manage associated price risk);</p> <p>Increase pool of available service providers</p> |

Section 7 Appendices

| Ability to control drivers of Generator Running | | |
|-------------------------------------------------|------------------------------------------------------------------------------------------------------------------------------------------------------------------------------------------------------------------------------------------------------------------------------------------------------------------------------------------------------------------------------------------------------------------------------------------------------------------------------------------------------------------------------------------------------------------------------------------------------------------------------------------------------------------------------------------------------------------------------------------------------------------------------------------------------------------------------------------------------------------------------------------------------------------------------------------------------------------------------------------------------------------------------------------------------------------------------------------------------------------------------------------------------------------------------------------------------------------------------------------------|-----------------------------------------------------------------------------------------------------------------------------------------------------------------------------------------------------|
| Tool | Extent of National Grid control | What does an incentive drive us to do? |
| | <p>Where there is a wide pool of available providers, services are procured via open tender – the more competition National Grid can generate, the more likely the pricing will be competitive.</p> <p>Ability to manage volume of generator running provision via contracts: Medium - high Ability to influence price of such contracts: Low – medium (depending on procurement method)</p> | |
| Transmission system planning/ operation | N/A | |
| Changes to operating policy | <p>National Grid’s Short-Term Operating Reserve Requirement (STORR) is set to ensure compliance with relevant policy. Changes in operating conditions may trigger the need to revise policy, which may vary the requirement for certain Balancing Services (and vice versa).</p> <p>Ability to manage volume of generator running via changes to operating policy: Medium (relies on driver for change) Ability to influence price of generator running via changes to operating policy: None - low</p> <p>The National Electricity Transmission System Security and Quality of Supply Standards (NETS SQSS) sets out a co-ordinated set of criteria and methodologies that apply to the planning of the national electricity transmission system.</p> <p>National Grid can work with the industry to develop the NETS SQSS to ensure response/reserve requirements remain appropriate to cater for the largest generation loss, although the ease with which the SQSS can be changed, and the associated timeframe, tends to depend on the magnitude of that change.</p> <p>However, National Grid could also incur a step-change in SO costs if changes to the SQSS impose different ways of working on it.</p> | <p>Ensure continued optimal requirement for response and reserve holding/provision;</p> <p>Develop NETS SQSS so that policies accommodate/ are consistent with the latest industry developments</p> |

Section 7 Appendices

| Ability to control drivers of Generator Running | | |
|--------------------------------------------------------|-------------------------------------------------------------------------------------------------------------------------------------------------------------------------------------------------------------------------------------------------------------------------------------------------------------------------------------------------------------------------------------------------------------------------------------------------------------------------------------------------------------------------------------------------------------------------------------------------------------------------------------------------------------------------------------------------------------------------------------------------------------------------------------------------------------------------------------------------|-----------------------------------------------------------------------------------------------------------------------------------------------------|
| Tool | Extent of National Grid control | What does an incentive drive us to do? |
| | Ability to influence transmission availability via changes to operating policy: Low | |
| Changes to industry codes | <p>The code change route could be used to propose changes to the imbalance regime such that incentives to manage portfolio risk were sharper. This may deliver more part-loaded BM Units and hence contribute towards margin provision.</p> <p>However it is important to note that certain code changes (such as those relating to imbalance as referenced above) would attract industry-wide interest and no doubt be contentious.</p> <p>The code change route could be used to propose changes to the arrangements for provision of mandatory ancillary services to National Grid (both in terms of quantity and cost).</p> <p>It is important to note that there may be considerable uncertainty regarding the success and timing of such proposed changes.</p> <p>Ability to influence generator running via code changes: Low</p> | Investigate how code provisions might influence generator running to better meet system operation needs |
| Information provision | <p>National Grid publishes a range of information to the industry through its Seven Year Statement, its own website and via submission to the Balancing Mechanism Reporting Agent (BMRA). Some of this information may influence generator running, for example demand forecasts and Short Term Operating Reserve requirements.</p> <p>Ability to influence generator running via information provision: Low</p> | Investigate how increased availability of information might lead to more effective functioning of the market with regard to system operator actions |
| Conclusion: | Degree of control by system operator = | Low to medium |

Table 37: Ability to control drivers of Generator Running

Section 7 Appendices

| Forecasting drivers of Demand Volatility | |
|------------------------------------------|---------------------------------------------------------------------------------------------------------------------------------------------------------------------------------------------------------------------------------------------------------------------------------------------------------------------------------------------------------------------------------------------------------------------------------------------------------------------------------------------------------------------------------------------------------------------------------------------------------------------------------------------------------------------------------------------------------------------------------------------------------------------------------------------------------------------------------------------------------------------------------------------------------------------------------------------------------------------------------------------------------------------------------------------------------------------------------------------------------------------------------------------------------------------------------------------------------------------------------------------------------------------------------------------------------------------------------------------------------|
| Measure | Detail |
| Is data readily available? | <p>Demand characteristics: YES National Grid has a wide range of historic demand data.</p> <p>Demand forecast error: YES National Grid is able to compare forecast demand with out-turn values.</p> <p>Demand NIV contribution: YES National Grid is able to obtain NIV from settlement data.</p> <p>SQSS Requirements: YES Data regarding required levels of high frequency response and 'footroom' to allow generation to be reduced following a loss of demand are readily available.</p> <p>Drivers behind data:</p> <p>TV pickups: YES Historic TV pickup data is readily available.</p> <p>Off-peak tariffs: YES The incidence of off-peak tariffs can be determined from out-turn demand data, from Distribution Network Operators or via interrogation of the radio teleswitch off-peak tariff management system.</p> <p>One-off events: YES (for historic events) Data from past one-off events is readily available.</p> <p>Forecasting methodology: YES National Grid's forecasting methodology is well understood.</p> <p>Suppliers' ability to forecast their energy requirements: NO Whilst National Grid can obtain NIV data, National Grid has no view of individual suppliers' forecasting or risk management processes.</p> |

Section 7 Appendices

| Forecasting drivers of Demand Volatility | |
|------------------------------------------|----------------------------------------------------------------------------------------------------------------------------------------------------------------------------------------------------------------------------------------------------------------------------------------------------------------------------------------------------------------------------------------------------------------------------------------------------------------------------------------------------------------------------------------------------------------------------------------------------------------------------------------------------------------------------------------------------------------------------------------------------------------------------------------------------------------------------------------------------------------------------------------------------------------------------------------------------------------------------------------------------------------------------------------------------------------------------------------------------------------------------------------------------------------------------------------------------------------------------------------------|
| Measure | Detail |
| | <p>HF response requirement: YES The HF response requirement is well understood</p> <p>Footroom: YES The need to hold sufficient downward reserve capability to cope with the largest credible demand loss at times of minimum demand is known.</p> |
| Volatility of drivers | <p>TV pickups: HIGH TV pickups depend on the size of TV audiences and the timing of commercial breaks. For established programmes on TV at regular times, they can exhibit stable behaviour. However they have the potential to exhibit significant volatility, particularly when associated with large sporting events.</p> <p>Off-peak tariffs: LOW Switching times of off-peak tariffs tend to be well established.</p> <p>One-off events: HIGH By their nature, the influence of one-off events on demand is highly uncertain.</p> <p>Forecasting methodology: LOW National Grid's forecasting methodology is well understood.</p> <p>Suppliers' ability to forecast their energy requirements: HIGH Each supplier needs to forecast and risk-manage its energy requirements against a varying customer base and imbalance cash-out risk.</p> <p>HF response requirement: LOW The HF response requirement is set by policy, which tends to be stable.</p> <p>Footroom: LOW The need to hold sufficient downward reserve capability to cope with the largest credible demand loss at times of minimum demand is set by policy, which tends to be stable.</p> |

Section 7 Appendices

| Forecasting drivers of Demand Volatility | |
|-----------------------------------------------|------------------------------------------------------------------------------------------------------|
| Measure | Detail |
| Applicability of historic data trend analysis | Other than for one-off events, historic demand data tends to provide useful data for trend analysis. |
| Conclusion: | Forecast confidence = Medium - high |

Table 38: Forecasting drivers of Demand Volatility

Section 7 Appendices

| Ability to control drivers of Demand Volatility | | |
|--------------------------------------------------------|---------------------------------------------------------------------------------------------------------------------------------------------------------------------------------------------------------------------------------------------------------------------------------------------------------------------------------------------------------------------------------------------------------------------------------------------------------------------------------------------------------------------------------------------------------------------------------------------------------------------------------------------------------------------------------------------------------------------------------------------------------------------------------------------------|--------------------------------------------------------------------------------------------------------------------------------------------------------------------------------------------------------------------------------------------------------------------------------------------------------------------------------------|
| Tool | Extent of National Grid control | What does an incentive drive us to do? |
| Balancing Mechanism (BM) | <p>The BM can only be used in the short-term to change output levels of generators that are already running or can be made to run in BM timescales. As long as the dynamic parameters of generation running in the BM allow, it can be used to track the demand profile. Rapid changes in demand tend to require specialist services to deliver energy in short timescales.</p> <p>Ability to influence demand volatility via the BM: Low</p> | Ensure efficient trade-off between expected prices/volumes available in the BM with options for trading/contracting pre-gate closure |
| Trades | <p>Trading tends to be for the delivery of defined blocks of energy. Hence it tends not to be used as a tool to manage demand volatility.</p> <p>Ability to influence demand volatility via trades: None</p> | N/A |
| Balancing Services contracts | <p>Balancing Services contracts provide National Grid with the ability to specify and procure a range of Balancing Services through the timescales.</p> <p>National Grid uses a range of Balancing Services contracts to manage demand volatility, from frequency response through fast reserve and other reserve products.</p> <p>National Grid looks to procure these services from a range of industrial and commercial load sources (either directly or via aggregators). National Grid has also in the past investigated the potential for staggering the start-time of domestic off-peak tariffs.</p> <p>Ability to manage demand volatility via contracts: Low - Medium Ability to influence price of such contracts: Low – medium (depending on procurement method)</p> | <p>Develop existing/new ancillary service mechanisms to manage demand volatility;</p> <p>Facilitate provision of such services by potential service providers;</p> <p>Attain prices better than those forecast to be available in the BM (and manage associated price risk);</p> <p>Increase pool of available service providers</p> |
| Transmission system planning/ operation | N/A | |
| Changes to operating policy | National Grid's Short-Term Operating Reserve Requirement (STORR) is set to ensure compliance with relevant policy. Changes in operating conditions may trigger the need to revise policy, which may vary the requirement for certain Balancing Services (and vice versa). | Ensure continued optimal requirement for response and reserve holding/provision; |

Section 7 Appendices

| Ability to control drivers of Demand Volatility | | |
|-------------------------------------------------|-------------------------------------------------------------------------------------------------------------------------------------------------------------------------------------------------------------------------------------------------------------------------------------------------------------------------------------------------------------------------------------------------------------------------------------------------------------------------------------------------------------------------------------------------------------------------------------------------------------------------------------------------------------------------------------------------------------------------------------------------|------------------------------------------------------------------------------------------------------------------------------------------------------------|
| Tool | Extent of National Grid control | What does an incentive drive us to do? |
| | <p>Ability to manage demand volatility via changes to operating policy: Medium Ability to influence price via changes to operating policy: None – low</p> <p>National Grid can work with the industry to develop the NETS SQSS to ensure response/reserve requirements remain appropriate to cater for the largest demand loss, although the ease with which the SQSS can be changed, and the associated timeframe, tends to depend on the magnitude of that change.</p> <p>However, National Grid could also incur a step-change in SO costs if changes to the SQSS impose different ways of working on it.</p> <p>Ability to influence transmission availability via changes to operating policy: Low</p> | <p>Develop NETS SQSS so that policies accommodate/ are consistent with the latest industry developments;</p> |
| Changes to industry codes | <p>The code change route could be used to investigate whether there was the opportunity for drivers for demand volatility could be managed prior to the system operation phase.</p> <p>Ability to influence demand volatility via code changes: Low</p> | <p>Investigate how code provisions might influence demand management to better meet system operation needs</p> |
| Information provision | <p>National Grid publishes a range of information to the industry through its Seven Year Statement, its own website and via submission to the Balancing Mechanism Reporting Agent (BMRA). Some of this information may be useful in influencing the timing of demand take.</p> <p>Ability to influence demand volatility via information provision: Low</p> | <p>Investigate how increased availability of information might lead to more effective functioning of the market with regard to system operator actions</p> |
| Conclusion: | Degree of control by system operator = | Low - medium (except demand contribution to NIV – None) |

Table 39: Ability to control drivers of Demand Volatility

Section 7 Appendices

| Forecasting drivers of Transmission Availability | |
|--------------------------------------------------|---------------------------------------------------------------------------------------------------------------------------------------------------------------------------------------------------------------------------------------------------------------------------------------------------------------------------------------------------------------------------------------------------------------------------------------------------------------------------------------------------------------------------------------------------------------------------------------------------------------------------------------------------------------------------------------------------------------------------------------------------------------------------------------------------------------------------------------------------------------------------------------------------------------------------------------------------------------------------------------------------------------------------------------------------------------------------------------------------------------------------------------------------------------------------------------------------------------------------------------------------------------------------------------------------------------------------------------------------------------------------------------------------------------------------------------------------------------------------------------------------------------------------------------------------------------------------------------------------------------------------------------------------|
| Measure | Detail |
| Is data readily available? | <p>Planned outage data: YES Transmission availability is notified to National Grid by TOs under the provisions of OC2 and is combined with National Grid's transmission availability information derived from its outage plans. Hence the data itself, once submitted, is readily available. Data quantity/quality decreases as the lead-time of the data increases.</p> <p>Unplanned outage data: YES National Grid becomes aware of faults with transmission equipment through its system operator function. If faults persist, they would become visible through OC2 data submissions.</p> <p>Drivers behind data:</p> <p>Connection scheme outages: YES Data relating to connection scheme outages is readily available, subject to lead time.</p> <p>Construction/maintenance outages: YES Data relating to construction and maintenance outages is readily available, subject to lead time.</p> <p>Contractor Availability: YES (National Grid), NO (Other TOs) National Grid's outage planners are able to determine contractor availability through the outage planning process. Whilst other TOs do the same, National Grid does not have access to information on their contractor availability.</p> <p>SQSS: YES The SQSS specifies criteria for the design and operation of the transmission system.</p> <p>Transmission equipment faults: YES Data relating to transmission system faults is readily available.</p> <p>Type faults/restrictions: YES Data relating to type faults/restrictions (once known) is readily available.</p> |

Section 7 Appendices

| Forecasting drivers of Transmission Availability | |
|--------------------------------------------------|-----------------------------------------------------------------------------------------------------------------------------------------------------------------------------------------------------------------------------------------------------------------------------------------------------------------------------------------------------------------------------------------------------------------------------------------------------------------------------------------------------------------------------------------------------------------------------------------------------------------------------------------------------------------------------------------------------------------------------------------------------------------------------------------------------------------------------------------------------------------------------------------------------------------------------------------------------------------------------------------------------------------------------------------------------------------------------------------------------------------------------------------------------------------------------------------------------------------------------------------------------------------------------------------------------------------------------------------------------------------------------------------------------------------------------------------------------------------------------------------------------------------------------------------------------------------------------------------------------------------------------------------------------------------------------------------------------------------------------------------------------------------------------------------------------------------------------------------------------------------------------------------------|
| Measure | Detail |
| Volatility of drivers | <p>Connection scheme outages: Varies with lead time Low (up to e.g. 4 weeks) – increasing to HIGH (beyond 6 months) Connection scheme outages are subject to variation associated with those schemes, hence dates can be subject to change and can be extremely difficult to forecast.</p> <p>Construction/maintenance outages: Varies with lead time Low (up to e.g. 4 weeks) – increasing to HIGH (beyond 6 months) Maintenance outages tend to be periodic in nature. However, construction/maintenance outages are subject to iterative planning processes and continuous assessment of system security. Hence, even once an outage plan has been finalised (currently at year-ahead) there is still the potential for significant change prior to real-time as stakeholders/third parties revise their plans, other equipment faults, delivery of equipment is delayed, etc.</p> <p>Contractor Availability: Varies with lead time Low (up to e.g. 4 weeks) – increasing to HIGH (beyond 6 months) Contractor availability can change, which for England and Wales transmission equipment National Grid has some control over. However, for equipment owned by other transmission owners, National Grid has no sight of/influence over contractor availability.</p> <p>SQSS: LOW System planning and operation requirements, being based on SQSS criteria, tend to change infrequently.</p> <p>Transmission equipment faults: HIGH Faults are random in nature, hence are highly volatile and cannot be forecast in a meaningful sense.</p> <p>Type faults/restrictions: Like faults, type faults/restrictions are random in nature, hence are highly volatile and cannot be forecast in a meaningful sense.</p> |
| Applicability of historic data trend analysis | <p>Planned outage data: NO Because of its drivers, planned outage data is unique to a particular time period and, other than the fact that outages tend to be taken over the lower-demand summer period, show no real trend in time.</p> <p>Unplanned outage data: NO The random nature of faults makes it difficult to use past history as an indication of when faults might occur, although a longer-term view</p> |

Section 7 Appendices

| Forecasting drivers of Transmission Availability | |
|--------------------------------------------------|----------------------------------------------------|
| Measure | Detail |
| | of history may provide an indication of frequency. |
| Conclusion: | Forecast confidence = Medium |

Table 40: Forecasting drivers of Transmission Availability

Section 7 Appendices

| Ability to control drivers of Transmission Availability | | |
|---------------------------------------------------------|----------------------------------------------------------------------------------------------------------------------------------------------------------------------------------------------------------------------------------------------------------------------------------------------------------------------------------------------------------------------------------------------------------------------------------------------------------------------------------------------------------------------------------------------------------------------------------------------------------------------------------------------------------|--------------------------------------------------------------------------------------------------------------------------------------------------------------------------------------------------------------------------|
| Tool | Extent of National Grid control | What does an incentive drive us to do? |
| Balancing Mechanism (BM) | N/A | N/A |
| Trades | N/A | N/A |
| Balancing Services contracts | N/A | N/A |
| Transmission system planning/operation | <p>National Grid's investment planning activity is a key driver behind the efficient development of the transmission system.</p> <p>National Grid's outage planning activity is a key driver behind the management of transmission system availability through the planning timescales.</p> <p>National Grid's planning roles enable it to work to co-ordinate transmission availability and investigate how to ensure the ongoing efficiency of planning processes.</p> <p>Ability to influence transmission availability via system planning/operation: Medium to high in the short-term, reducing in the medium – long term</p> | <p>Develop outage planning processes; Innovate with regard to running arrangements and development of post-fault system management tools; Investigate technical solutions to maximise transmission system capability</p> |
| Changes to operating policy | <p>The National Electricity Transmission System Security and Quality of Supply Standards (NETS SQSS) sets out a co-ordinated set of criteria and methodologies that apply to the planning of the national electricity transmission system.</p> <p>National Grid can work with the industry to develop the NETS SQSS to ensure its planning criteria remain appropriate, although the ease with which the SQSS can be changed, and the associated timeframe, tends to depend on the magnitude of that change.</p> <p>However, National Grid could also incur a step-change in SO costs if changes to the SQSS impose different ways of working on it.</p> | <p>Develop NETS SQSS so that policies accommodate/ are consistent with the latest industry developments; Ensure appropriate levels of transmission system security through network planning</p> |

Section 7 Appendices

| Ability to control drivers of Transmission Availability | | |
|----------------------------------------------------------------|----------------------------------------------------------------------------------------------------------------------------------------------------------------------------------------------------------------------------------------------------------------------------------------------------------------------------------------------------------------------------------------------------------------------------------------------------------------------------------------------------------------------------------------------------------------------------------------------|-------------------------------------------------------------------------------------------------------------------------------------------------------------|
| Tool | Extent of National Grid control | What does an incentive drive us to do? |
| | Ability to influence transmission availability via changes to operating policy: Low | |
| Changes to industry codes | The code change route could be used to propose changes to outage co-ordination processes with the aim of ensuring their continued efficiency. In the context of transmission system availability/capability, code changes might be a route to enhancing the collective aim of transmission owners to maximise availability, although as with generator availability it might be that enhanced licence obligations to minimise constraint costs through efficient co-ordination could be more appropriate. Ability to influence transmission availability via code changes: Low | Investigate how increased co-ordination and efficiency between code parties might be possible and what the benefit for the outage planning process might be |
| Information provision | National Grid publishes information on transmission system capability to the industry through its Seven Year Statement. National Grid consults with the industry regarding the quantity and type of information it provides, some of which (in conjunction with locational use of system charging, may influence generator/demand decisions on where to site, with a corresponding impact on the requirement for transmission capacity. Ability to influence transmission availability/ capacity via information provision: Low | Investigate how increased availability of information might lead to more effective functioning of the market with regard to system operator actions |
| Conclusion: | Degree of control by system operator = | Medium |

Table 41: Ability to control drivers of Transmission Availability

Section 7 Appendices

| Forecasting drivers of Transmission Capability | |
|------------------------------------------------|--------------------------------------------------------------------------------------------------------------------------------------------------------------------------------------------------------------------------------------------------------------------------------------------------------------------------------------------------------------------------------------------------------------------------------------------------------------------------------------------------------------------------------------------------------------------------------------------------------------------------------------------------------------------------------------------------------------------------------------------------------------------------------------------------------------------------------------------------------------------------------------------------------------------------------------------------------------------------------------------------------------------------------------------------------------------------------------------------------------------------------------------------------------------------------------------------------------------------------------------------------------------------------------------------------------------------------------------------------------------------------------------------------------------------------------------------------------------------------------------------------------------------------------------------------------------------------------------------------------------------------------------------------------------------------------------------------------------------------------------------------------------------------------------------------------------------------------------------------------------------------------------------------------------------|
| Measure | Detail |
| Is data readily available? | <p>Equipment ratings: YES Detailed ratings information for National Grid's transmission equipment is readily available. Rating information for other TOs' equipment is provided to National Grid under the provisions of the SO-TO Code.</p> <p>SQSS Requirements: YES Criteria for pre- and post-fault operational voltage, thermal and stability standards arising from SQSS requirements are readily available.</p> <p>Post-fault actions: YES Post-fault actions include (but are not limited to) switching of transmission equipment, agreeing of Special Actions under the terms of the Grid Code, and agreeing Balancing Services contracts. Data for agreed post-fault actions are readily available.</p> <p>Drivers behind data:</p> <p>Plant characteristics: YES (National Grid), NO (Other TOs) Data relating to National Grid's plant characteristics is readily available. Data relating to other TOs' plant characteristics may be available under the provisions of the SO-TO Code.</p> <p>Weather/season impact: YES Data relating to the impact of seasons National Grid's plant characteristics is readily available. Data relating to the impact of seasons on other TOs' plant characteristics may be available under the provisions of the SO-TO Code.</p> <p>Certain of National Grid's equipment have monitoring equipment that allows for more dynamic assessment of characteristics, depending on local weather conditions.</p> <p>Voltage criteria, Loss of supply criteria: YES The SQSS specifies criteria for maintaining system voltage and when loss of supply is acceptable.</p> <p>Availability of reactive power: YES Data relating to the reactive power absorption/generation of National Grid's transmission assets, including reactive compensation equipment, is readily available.</p> |

Section 7 Appendices

| Forecasting drivers of Transmission Capability | |
|------------------------------------------------|-------------------------------------------------------------------------------------------------------------------------------------------------------------------------------------------------------------------------------------------------------------------------------------------------------------------------------------------------------------------------------------------------------------------------------------------------------------------------------------------------------------------------------------------------------------------------------------------------------------------------------------------------------------------------------------------------------------------------------------------------------------------------------------------------------------------------------------------------------|
| Measure | Detail |
| | <p>Data relating to the reactive power absorption/generation of other TOs' plant characteristics is available under the provisions of the SO-TO Code.</p> <p>Data relating to the reactive power capability if generators (as required by the Grid Code) are contained within CUSC-governed mandatory ancillary service agreements (and other Balancing Services agreements).</p> <p>Substation reconfiguration: YES Information relating to potential substation reconfigurations are retained within National Grid's knowledge base.</p> <p>Generation output 'drops': YES Generators' ability to provide rapid de-loads post-fault are agreed as part of the Grid Code 'Special Actions' process.</p> <p>Intertrips: YES Data relating to installed intertrip schemes are readily available to National Grid.</p> |
| Volatility of drivers | As the drivers above relate either to plant characteristics or operating policy, their volatility can be considered to be LOW . |
| Applicability of historic data trend analysis | As the drivers above relate either to plant characteristics or operating policy, it is reasonable to assume they will be stable looking forward. |
| Conclusion: | Forecast confidence = Medium - high |

Table 42: Forecasting drivers of Transmission Capability

Section 7 Appendices

| Ability to control drivers of Transmission Capability | | |
|--------------------------------------------------------------|-------------------------------------------------------------------------------------------------------------------------------------------------------------------------------------------------------------------------------------------------------------------------------------------------------------------------------------------------------------------------------------------------------------------------------------------------------------------------------------------------------------------------------------------------------------------------------------------------------------------------------------------------------------------------------------------------------------------------------------------------------------------------------------------------------|-------------------------------------------------------------------------------------------------------------------------------------------------------------------------------------------------------------------------------------------------|
| Tool | Extent of National Grid control | What does an incentive drive us to do? |
| Balancing Mechanism (BM) | <p>The BM does not allow National Grid to directly control transmission capability, although it is a tool by which generation/demand may be rescheduled to resolve any transmission constraints (thermal, voltage or stability) that may arise post-transmission equipment fault, therefore influencing the transmission capability of the remaining system.</p> <p>Ability to influence transmission capability via the BM: Low</p> | Ensure efficient trade-off between expected prices/volumes available in the BM with options for trading/contracting pre-gate closure |
| Trades | <p>As for the BM, National Grid's ability to trade ahead of gate closure does not allow it to directly control transmission capability, though it does provide a further tool by which expected generation/demand may be rescheduled pre-fault to resolve any transmission constraints.</p> <p>Ability to influence transmission capability via trades: Low</p> | Develop/enhance trading strategies; Extend the availability of GTMA Schedule 7A to enable BM Unit-specific trades from a wider pool of counter-parties |
| Balancing Services contracts | <p>As for the BM and trades, do not allow National Grid to influence transmission capability, although they provide a number of potential means by which available capability can be influenced:</p> <ul style="list-style-type: none"> • Intertrip/fast de-load agreements allow for overloads to be resolved in the event of a fault, rather than restricting generation pre-fault; • Reactive power agreements/market arrangements can be used to enhance the value of services offered <p>The available pool of service providers and consequential impact for procurement mechanisms influences the extent to which National Grid can influence the price of such services.</p> <p>Ability to influence transmission capability via contracts: Medium to high</p> | Develop existing/new ancillary service mechanisms to enhance post-fault generator action capability (e.g. intertrips); Facilitate provision of such services by potential service providers; Increase pool of available service providers |
| Transmission system planning/operation | <p>The outage planning and system control functions are instrumental in developing the tools and techniques available to support efficient system operation against a background of changing system availability and capability:</p> <ul style="list-style-type: none"> • Substation re-switches • Identification of transmission and generation post-fault actions | Develop outage planning processes; Innovate with regard to running arrangements and development of post-fault system management tools; Investigate technical solutions to maximise transmission system capability |

Section 7 Appendices

| Ability to control drivers of Transmission Capability | | |
|--------------------------------------------------------------|-------------------------------------------------------------------------------------------------------------------------------------------------------------------------------------------------------------------------------------------------------------------------------------------------------------------------------------------------------------------------------------------------------------------------------------------------------------------------------------------------------------------------------------------------------------------------------------------------------------------------|------------------------------------------------------------------------------------------------------------------------------------------------------------------------------------------------------------------------|
| Tool | Extent of National Grid control | What does an incentive drive us to do? |
| | Ability to influence transmission capability via system planning/operation: Medium to high | |
| Changes to operating policy | <p>The National Electricity Transmission System Security and Quality of Supply Standards (NETS SQSS) sets out a co-ordinated set of criteria and methodologies that apply to the operation of the national electricity transmission system.</p> <p>National Grid can work with the industry to develop the NETS SQSS to ensure its operational criteria remain appropriate.</p> <p>However, National Grid could also incur a step-change in SO costs if changes to the SQSS impose different ways of working on it.</p> <p>Ability to influence transmission capability via changes to operating policy: Low</p> | <p>Develop NETS SQSS so that policies accommodate/ are consistent with the latest industry developments;</p> <p>Ensure appropriate levels of transmission system security during both intact and outage conditions</p> |
| Changes to industry codes | <p>The code change route could be used to propose changes to the requirement to make available post-fault actions. In the context of transmission system capability, code changes might be a route to enhancing the collective aim of transmission owners to maximise capability.</p> <p>Ability to influence transmission capability via code changes: Low</p> | <p>Investigate how increased co-ordination and efficiency between code parties might be possible and what the benefit for the managing transmission capability might be</p> |
| Information provision | <p>National Grid publishes information on transmission system capability to the industry through its Seven Year Statement. National Grid consults with the industry regarding the quantity and type of information it provides, some of which (in conjunction with locational use of system charging, may influence generator/demand decisions on where to site, with a corresponding impact on the requirement for transmission capacity.</p> <p>Ability to influence transmission capability via information provision: Low</p> | <p>Investigate how increased availability of information might lead to more effective functioning of the market with regard to system operator actions</p> |
| Conclusion: | Degree of control by system operator = | Medium |

Table 43: Ability to control drivers of Transmission Capability

3. Appendix C: Modelled Transmission System Boundaries

Boundaries included in the model:

Scotland North:

SSENWEX

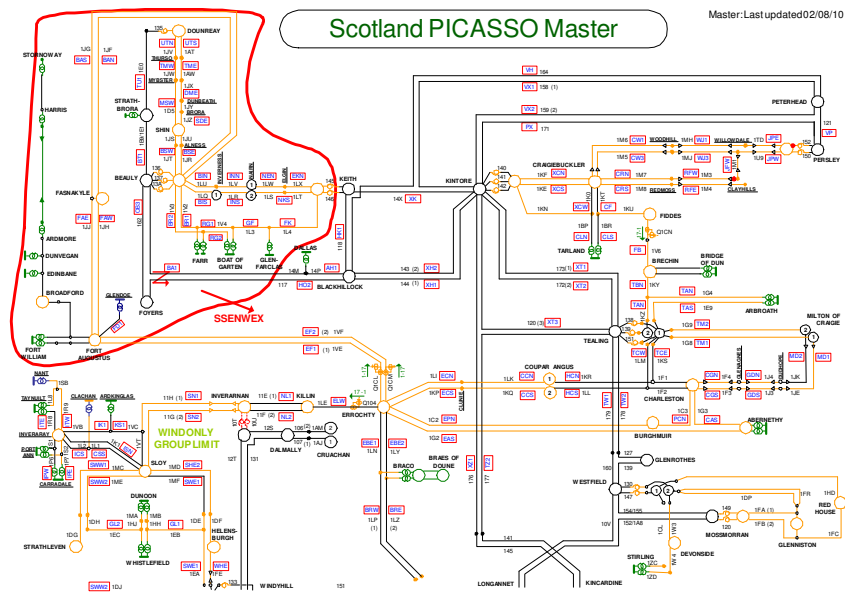

1. This boundary captures the issues resulting from the heavy concentration of wind generation in the area. (Beaulieu – Denny circuit planned to resolve)

SSE N-S

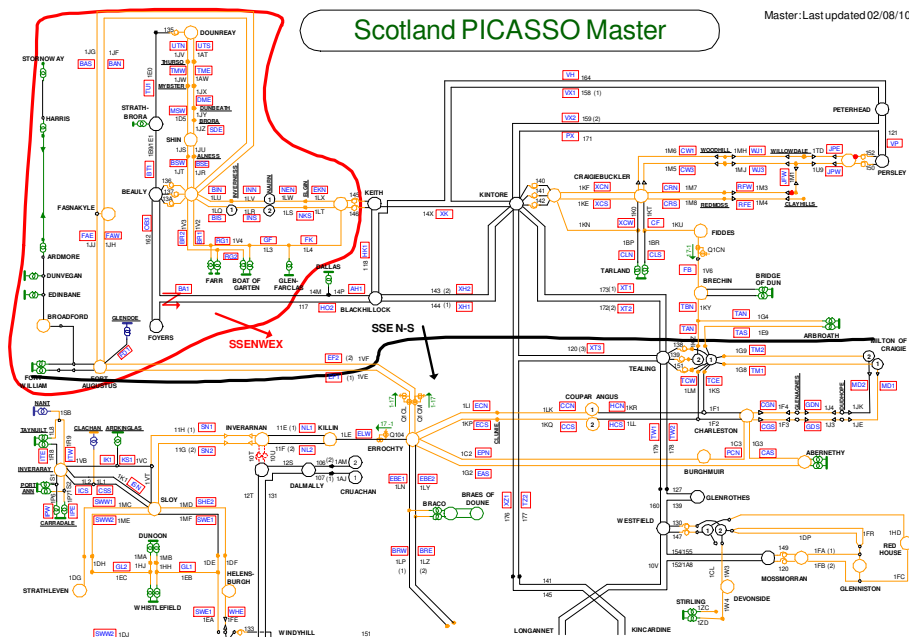

Section 7 Appendices

- The boundary is used to capture all issues associate with high transfers from wind generation combined with generation at Peterhead. The loss of either of the 275kV routes (shown in black) which the boundary crosses can lead to unacceptable overloads on the remaining circuits.

KINTYRE WIND ONLY

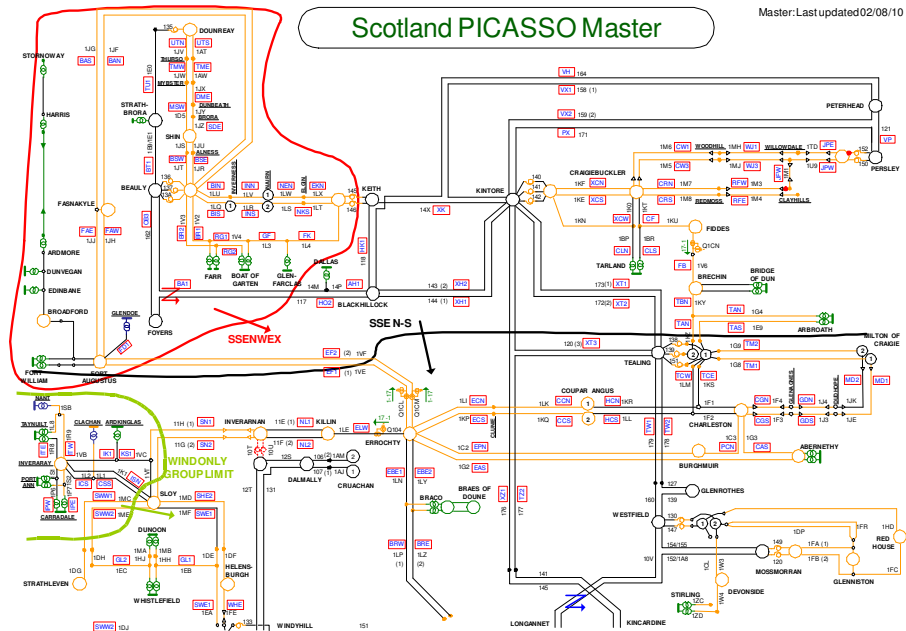

- All generation behind this boundary is wind generation. As such, costs to manage any constraints can be significant. Under the Connect and Manage Regime, this boundary is likely to become active under pre and post fault conditions.

SSE- SP

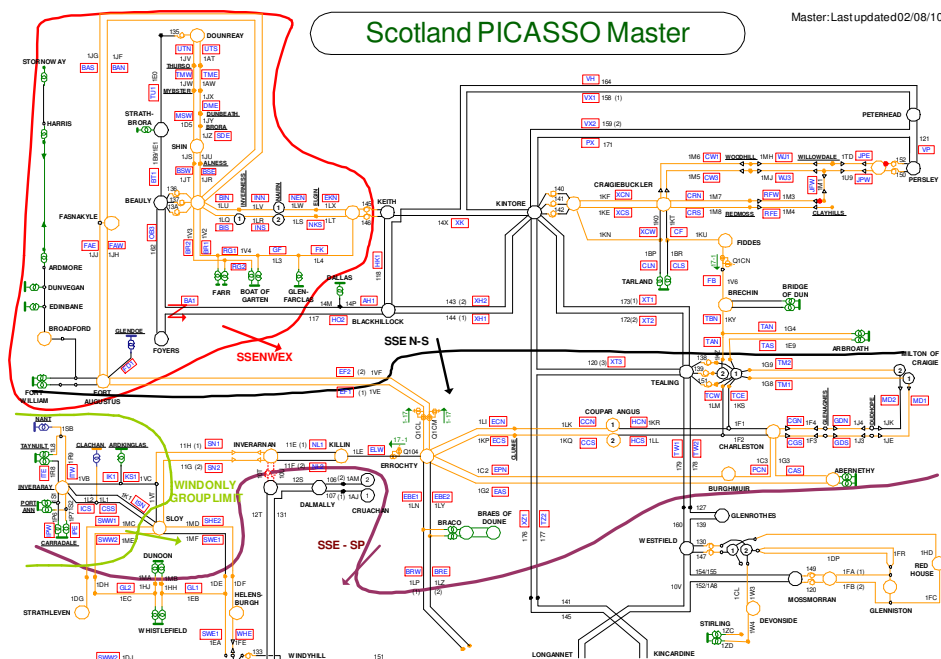

Section 7 Appendices

- SSE –SP boundary is not typically used in Operational timescales as a boundary to describe a specific issue in more detail would be preferred. For modelling purposes, it can be used to adequately describe issues associated with the loss of a 275kV route against a combination of Peterhead and all northern wind generation.

NLOANSSE

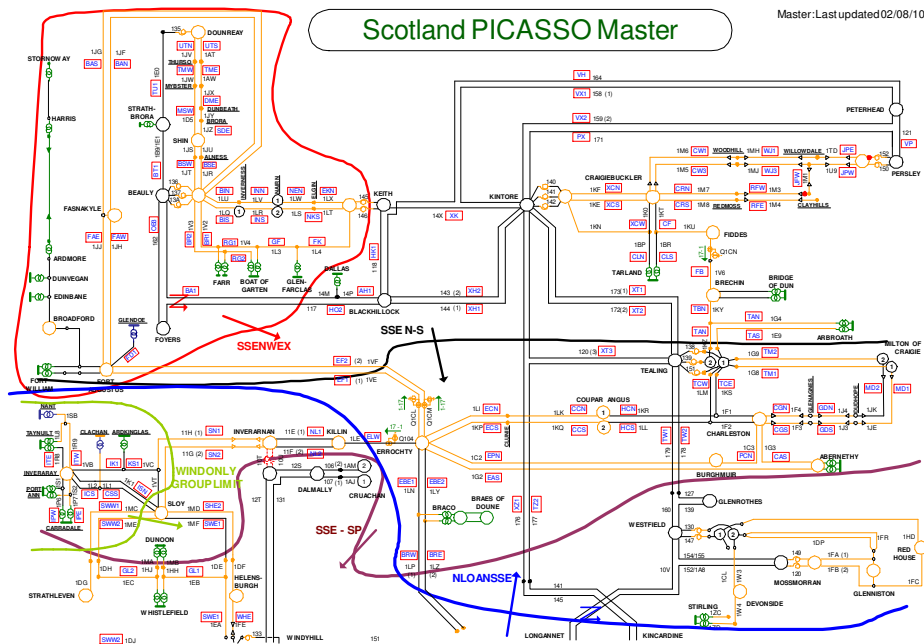

- NLOANSSE becomes active when there is insufficient generation in the North of Scotland to meet demand and high flows from Southern Scotland are observed.

Scotland Central:

CENTRAL SCOTLAND STABILITY LIMIT

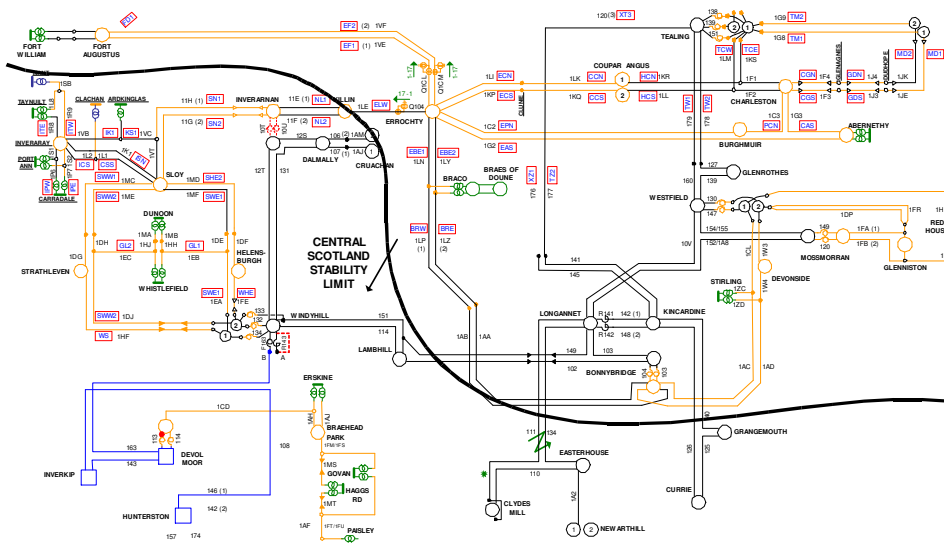

- System instability constrains the transfer that can be secured across this boundary. The transfer that can be secured across this boundary is heavily dependant on the number of

Section 7 Appendices

Longannet generators synchronised and the output of each generator. This is modelled by considering only the output of generation at Longannet and using the corresponding limit.

SSE + GRMO

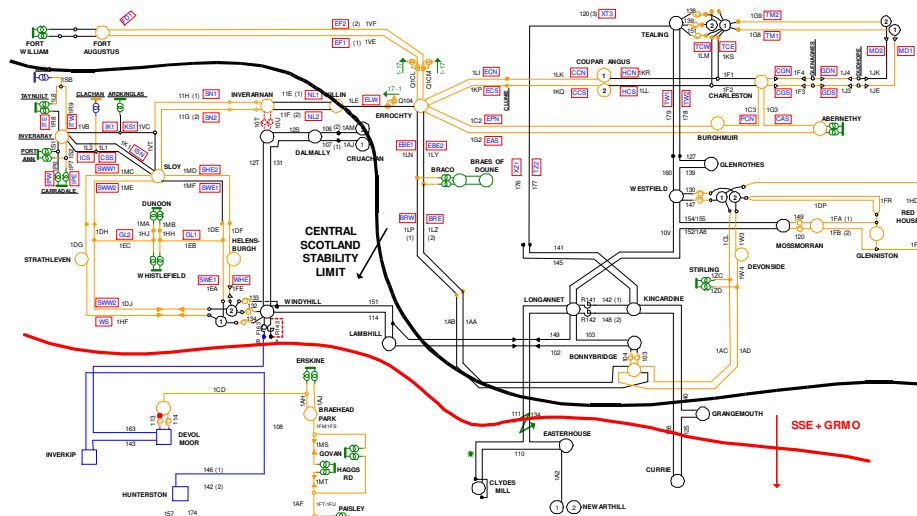

- This boundary describes a thermal limit on the transfers which can be secured. A programme of works at several substations on the boundary has increased the boundary capability. It is not likely to be a limiting boundary on the system prior to completion of the Beauldy-Denny circuit.

Scotland South

SC-BORD

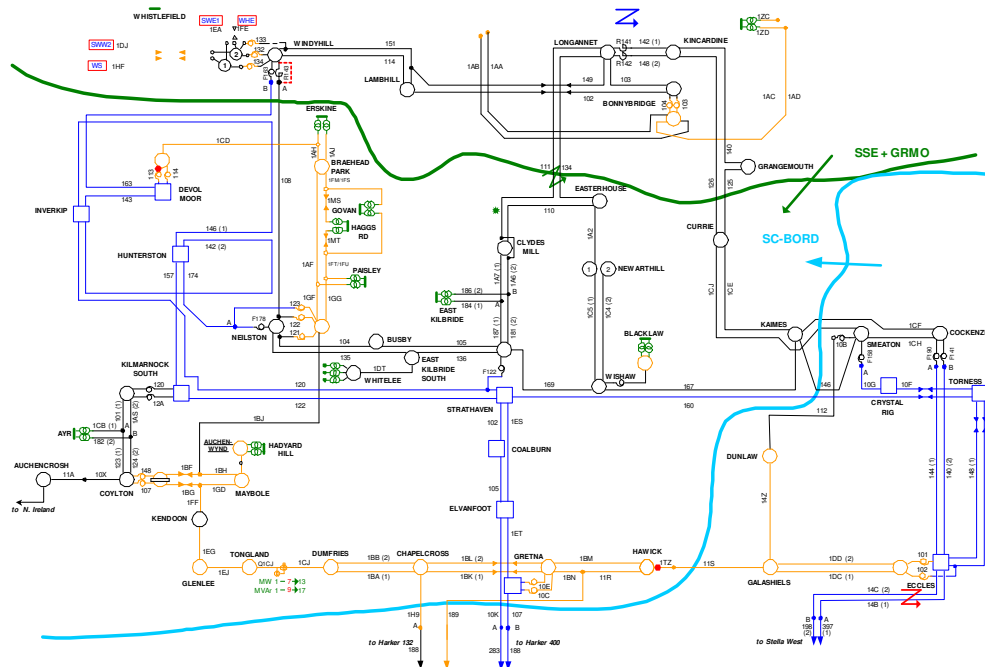

- When there is insufficient generation synchronised within Scotland to meet Scottish demand, generation on the English side of the SC BORD constraint looks to meet the demand. This causes high transfers across the boundary as Cockenzie, Torness (and other generation in the group) generation flows North – West into Scotland rather than South to England. As such, the transfer that can be secured is dependant on the output of generation within Scotland (captured by the SSE + GRMO limit)

Section 7 Appendices

16. LOWFLSTH captures issues associated with insufficient generation across the South of England. This limit can be active under both pre and post fault conditions. This limit is typically managed by increasing generation in the South or trading to increase imports on the IFA.

SWALEX3

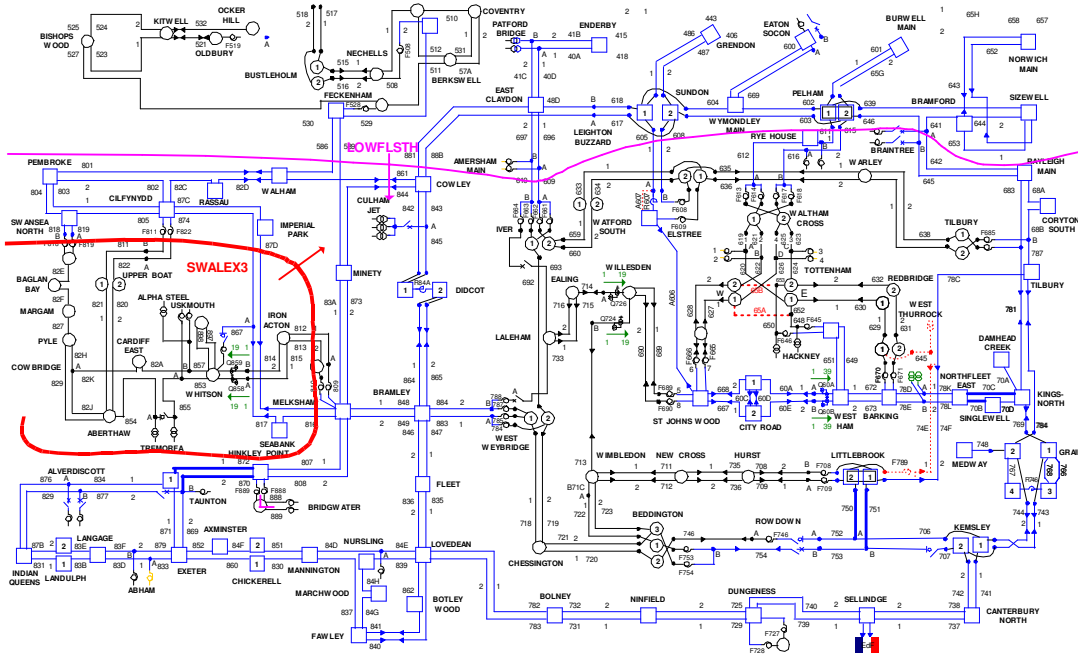

17. This boundary is one which may not be active in 11/12/13 and one which is expected to be active only under outage conditions. As new generation connects in the area, outages on several circuits in the area will be required.

ARMCHAR

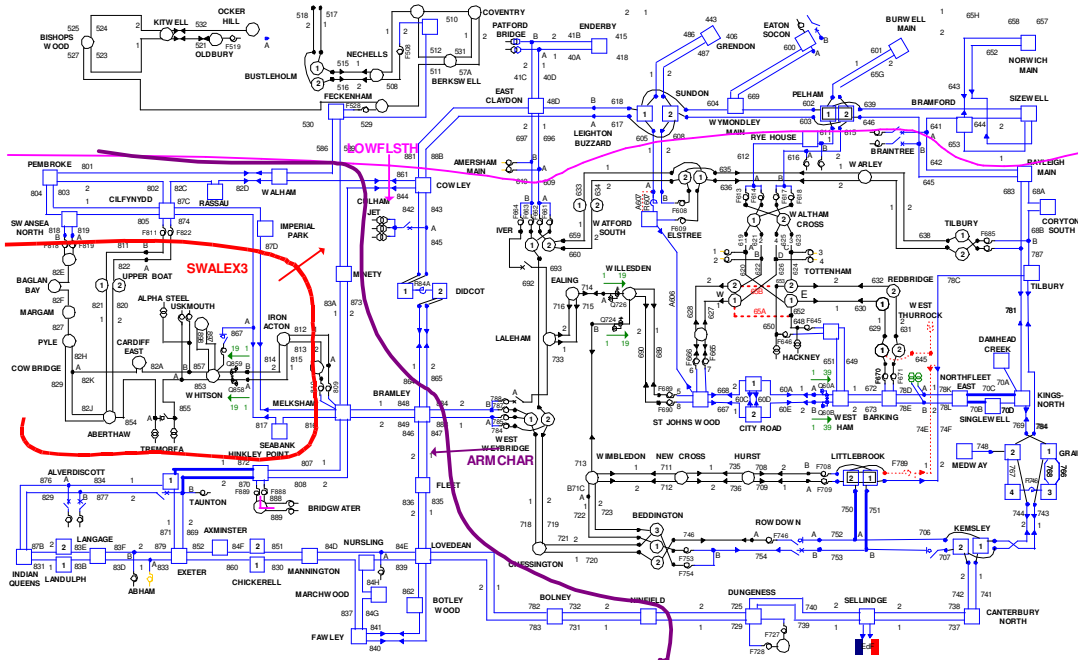

18. The ARMCHAR boundary describes an import constraint which ensures that there is sufficient generation in the South West of England to prevent unacceptable voltage conditions or loading of transmission equipment following the loss of a double circuit route into the area.

Section 7 Appendices

ESTEX1

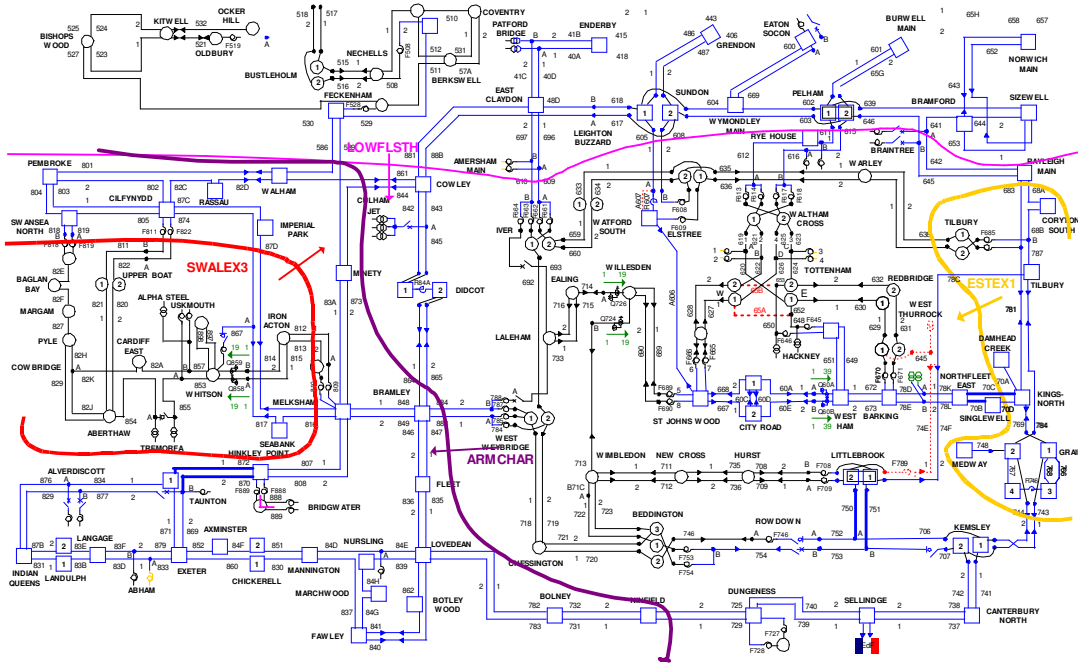

19. During periods of high output from Thames Estuary generation with exports or low imports on the IFA the loss of a double circuit route from the Thames Estuary will result in unacceptable loading of the remaining circuits. Imports from Netherlands on BritNed during such periods (loop flows) would exacerbate the existing issues.

ESTEX3

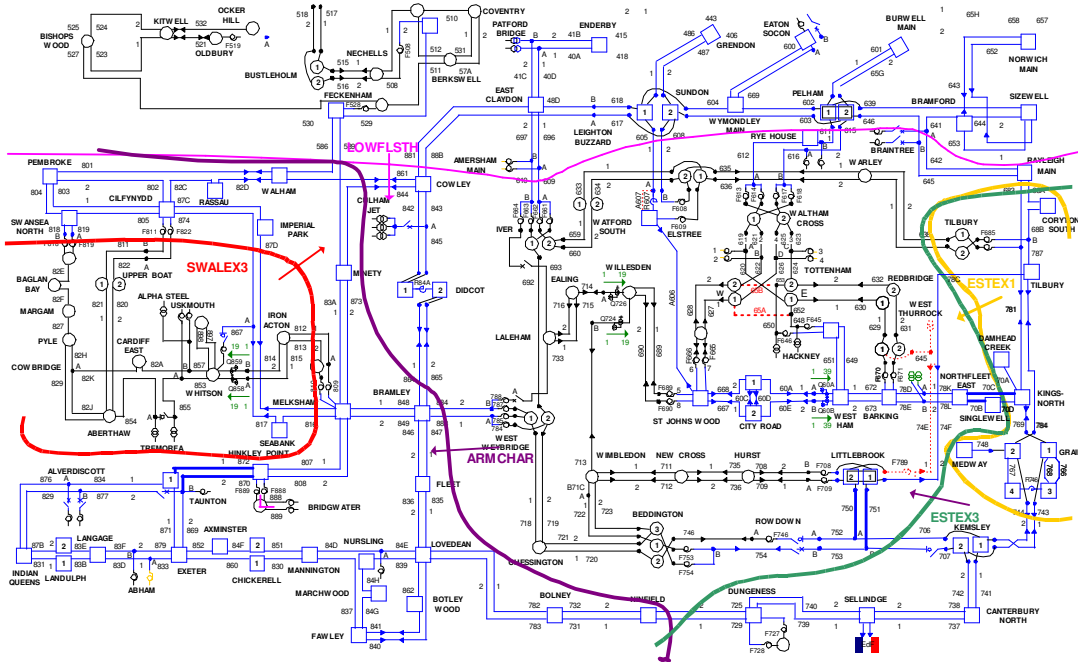

20. ESTEX3 describes issues observed in the South East of England (Thames Estuary, greater London and along the South Coast) during periods of high output from Thames Estuary generation combined with imports on the IFA and/or on BritNed.

4. Appendix D: List of Consultation Questions

The questions below have been constructed to assist the development and implementation of the proposed new approach to incentives. National Grid values your views and feedback. Whilst extensive, the list of questions is not exhaustive – if you have further points you would like to raise, please do so.

Question 1: To what extent do you think that the proposed approach to incentivisation, with the use of Ex-Post data for volatile, difficult to forecast parameters, will result in more appropriate incentivisation of National Grid's system operator activities?

Question 2: Do you agree with the criteria used by National Grid to assess the extent to which it can forecast or control BSIS drivers? Are there other criteria that you think National Grid should consider?

Question 3: What are your views on National Grid's conclusions regarding the treatment of Generation Availability in BSIS models?

Question 4: What are your views on National Grid's conclusions regarding the treatment of Generation Running in BSIS models?

Question 5: What are your views on National Grid's conclusions regarding the treatment of Demand Volatility in BSIS models?

Question 6: What are your views on National Grid's conclusions regarding the treatment of Transmission Availability in BSIS models?

Question 7: What are your views on National Grid's conclusions regarding the treatment of Transmission Capability in BSIS models?

Question 8: To what extent do you think that National Grid's proposed approach to delivering a modelled target cost for Energy Imbalance will act as an appropriate incentive to deliver cost efficiencies?

Question 9: To what extent do you think that National Grid's proposed approach to delivering a modelled target cost for Margin will act as an appropriate incentive to deliver cost efficiencies?

Question 10: To what extent do you think that National Grid's proposed approach to delivering a modelled target cost for Fast Reserve will act as an appropriate incentive to deliver cost efficiencies? Are there any areas where you think that improvements to the models could be made?

Question 11: To what extent do you think that National Grid's proposed approach to delivering a modelled target cost for Frequency Response will act as an appropriate incentive to deliver cost efficiencies?

Question 12: To what extent do you think that National Grid's proposed approach to delivering a modelled target cost for Footroom will act as an appropriate incentive to deliver cost efficiencies?

Question 13: To what extent do you think that National Grid's proposed approach to delivering a modelled target cost for reactive power will act as an appropriate incentive to deliver cost efficiencies?

Section 7

Appendices

Question 14: To what extent do you consider that there exists the potential for windfall profit or loss under the scheme if a single snapshot of the generation outage plan were to be taken prior to scheme start (and used in the models for the duration of the scheme)?

Question 15: To what extent do you consider that a rolling Ex-Ante approach to modelling planned generation outages, as notified via Grid Code OC2 processes, is an appropriate mechanism to ensure the modelled outage plan remains representative (and suitable for incentivisation)? What other mechanisms could be considered?

Question 16: To what extent do you consider that there exists the potential for windfall profit or loss under the scheme if unplanned generator availability is not considered when calculating target costs for constraint management incentivisation?

Question 17: Do you agree that treating generation faults as an Ex-input to [constraint] models is an appropriate mechanism to ensure the modelled target cost remains representative (and suitable for incentivisation)?

Question 18: To what extent do you consider that there exists the potential for windfall profit or loss under the scheme if a single snapshot of the transmission outage plan were to be taken prior to scheme start (and used in the models for the duration of the scheme)?

Question 19: To what extent do you think that BM price submissions can reasonably be forecast?

Question 20: What are your views on the use of submitted BM prices Ex-Post as a means of determining target costs for constraint management?

Question 21: What are your views on the use of a 'pseudo BM price' to apply to contracted BM Units when calculating target constraint costs? To what extent do you agree that the options outlined in paragraph 355 might be suitable?

Question 22: Do you agree that National Grid should be incentivised to beat historic constraint contracting performance?

Question 23: If yes, what in your view is the most appropriate way to achieve this in practice?

Question 24: To what extent do you agree with National Grid's views on the need for a cost 'dead-band' under the proposed approach to incentivisation?

Question 25: To what extent do you agree with National Grid's views on the magnitude of the profit cap and loss floor under the proposed approach to incentivisation?

Question 26: To what extent do you agree with National Grid's views on the magnitude of sharing factors under the proposed approach to incentivisation? What do you consider to be an appropriate level of sharing factor?

Question 27: Do you agree that National Grid should be concerned about the potential for parties to influence its performance under the incentive scheme by using information that it makes available to the wider industry?

Question 28: Do you agree that the creation of an open, transparent statement describing National Grid's methodology for determining whether model inputs should be treated on an Ex-Ante or Ex-Post basis is appropriate?

Question 29: What are your expectations of National Grid when it comes to the production of an Incentivised Balancing Cost/BSUoS charge forecast?

Question 30: What are your views on the timing of such forecasts? For example, do you have processes that will be impacted by the timing of publication of an IBC/BSUoS forecast?

Section 7 Appendices

Question 31: Do you agree with the concept of (and need for) a Scheme Adjusting Event? If so, what sort of events do you consider it appropriate to adjust for?

Question 32: To what extent do you consider that the scheme needs to be able to cope with the 'known unknowns' listed in section 4.4.2? How might the impact of these events be managed?

Question 33: Do you consider that your systems will be impacted by the proposed change to scheme structure outlined in these Initial Proposals? If so, what information will you require (and in what timescales) in order to accommodate the change?