

# Sharing between nodes

---

Straw man

# How can users share without zones?

---

1. Exchange rate based on ratio of (ex post) overrun charges
2. SO calculates fixed point-to-point exchange rate based on volume and duration
3. SO releases point-to-point access rights in investment timescales

# 1. Exchange rate based on ratio of (ex post) overrun prices (1)

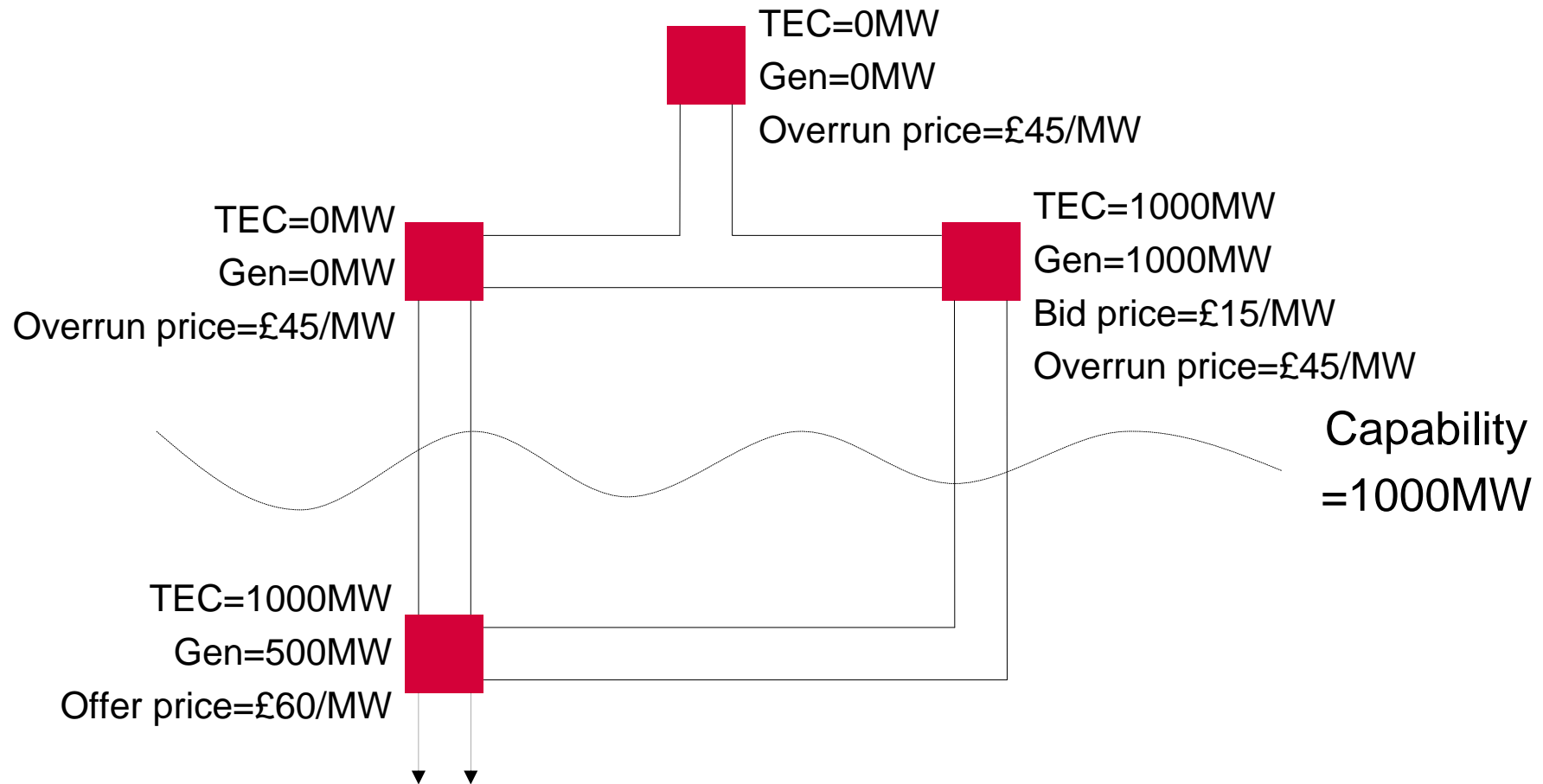

# 1. Exchange rate based on ratio of (ex post) overrun prices (2)

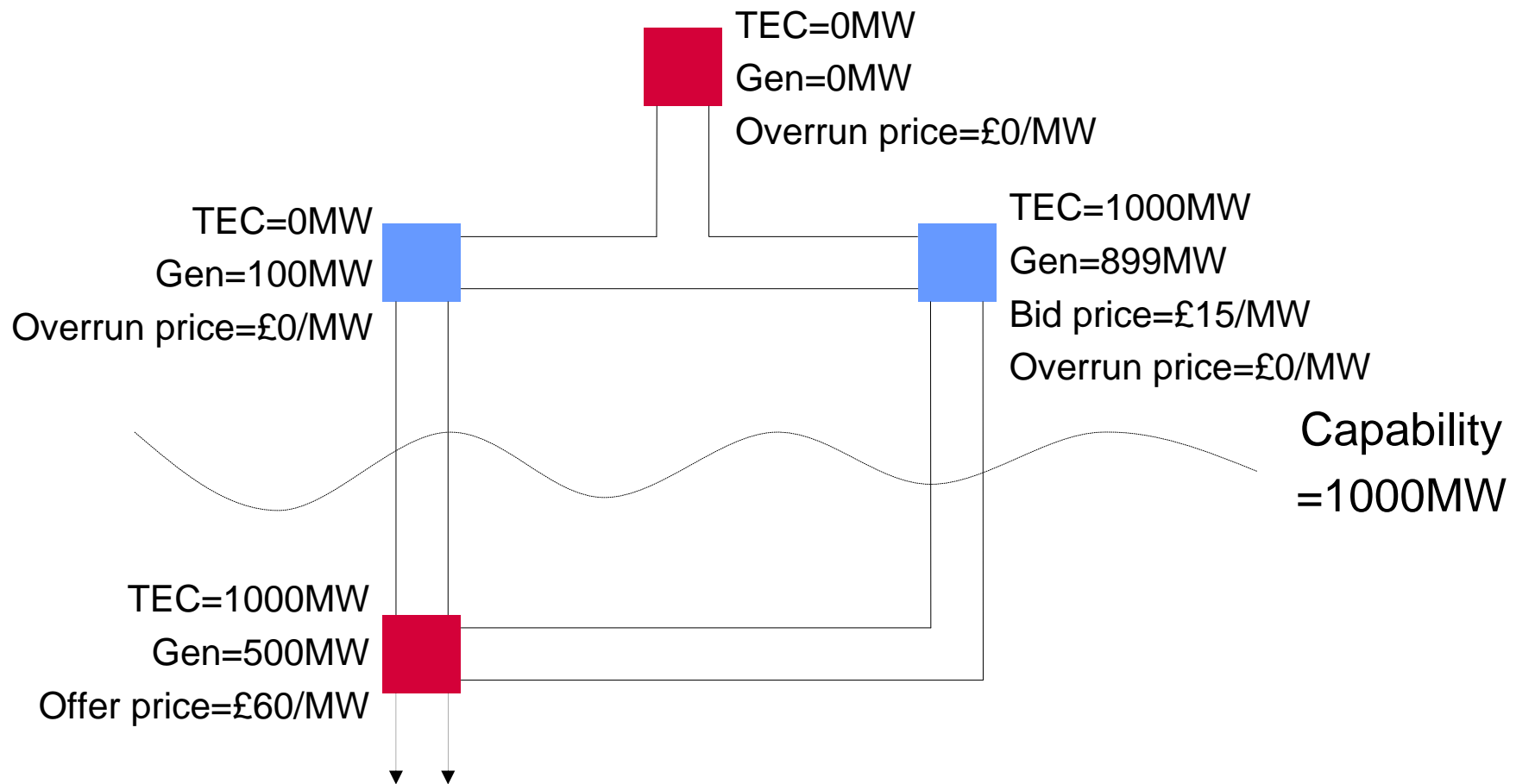

Generators can share based on overrun price alone provided there are no third parties generating

# 1. Exchange rate based on ratio of (ex post) overrun prices (3)

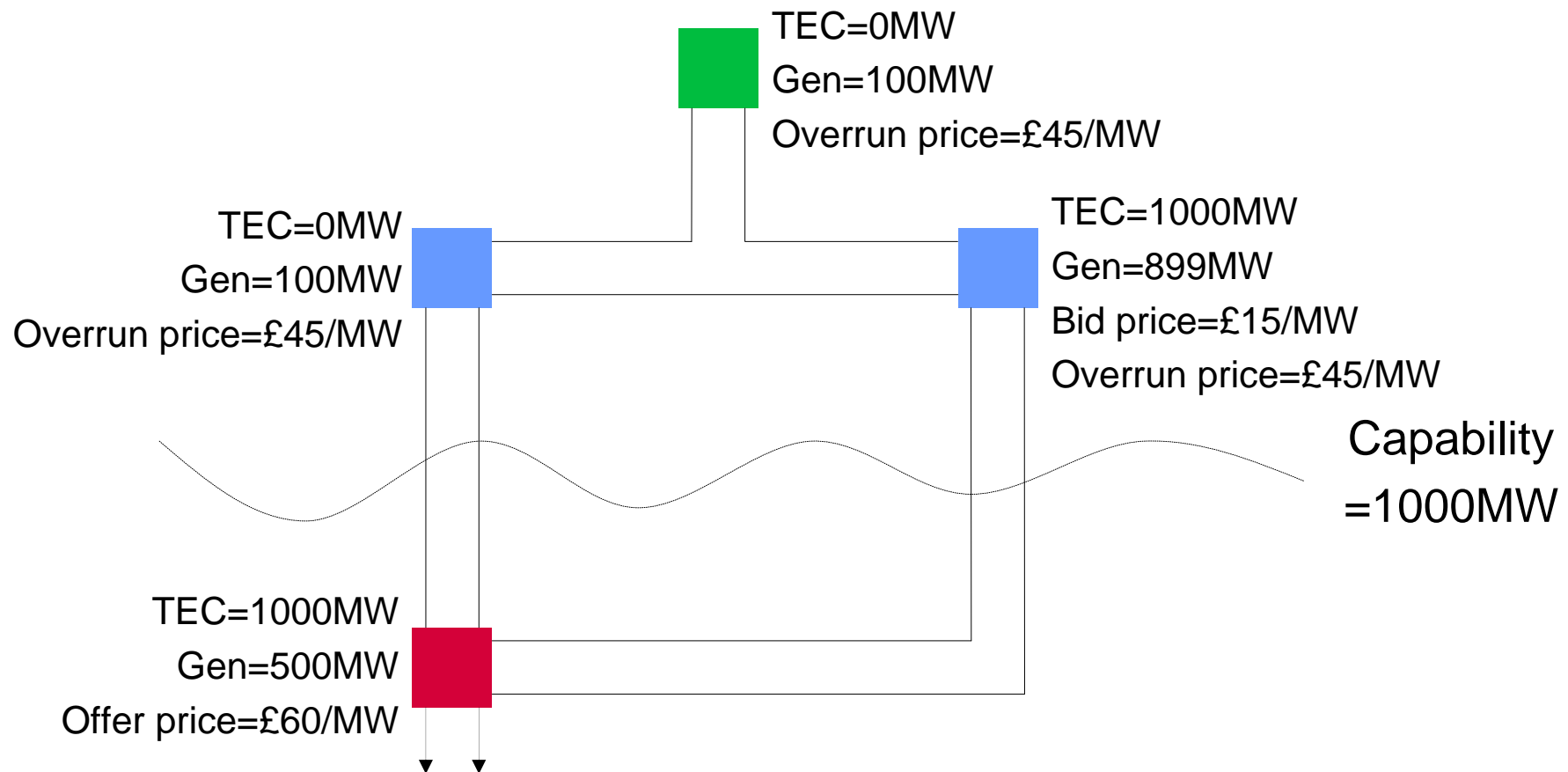

Generation from third party invalidates sharing arrangement.  
User with TEC is not getting full value for holding.  
Solution is exchange rate based on overrun prices

### 3. Exchange rate based on ratio of (ex post) overrun prices (4)

---

- ◆ How?
  - ◆ Users would notify SO of sharing arrangement
  - ◆ SO would calculate exchange rates based on (ex post) overrun prices
  - ◆ Results from calculations form inputs to calculation of overrun volume
  
- ◆ Further development required by WG1

## 2. SO calculates fixed point-to-point exchange rate based on volume and duration

---

- ◆ Why?
  - ◆ Whilst the risks associated with overrun exchange rates may be acceptable for users located close together, this is unlikely to be the case if they're further apart. If they are unwilling to live with these risks (but still want to share) they can apply to NG for a fixed exchange rate
- ◆ How?
  - ◆ User applies to NG for a fixed exchange rate between [node A] and [node B] for a maximum volume of [x]MW and a duration of [y] months/years. It is crucial that we know the donor node, recipient node, maximum volume and duration in order to manage the risks associated with capacity exchange
  - ◆ NG assess application against current baseline capacity (operational assessment for within year durations; planning assessment for durations that go beyond current year) and calculate exchange rate that does not impact other circuits by > [agreed tolerance]. National Grid take account of planned system outages in operational timescales.
  - ◆ NG offer exchange rate. Offer is open for 3 months. If users accepts, exchange rate is recorded and used in overrun volume calculations and future 'applications' for capacity/exchange rates.
  - ◆ User pays [?] for within year durations and [?] for durations that go beyond current year

### 3. SO releases point-to-point access rights in investment timescales

---

- ◆ Why?
  - ◆ If the fixed exchange rate (given by 2) is unacceptably low, users may want TOs to invest to achieve a point-to-point capability. This investment may be minor (and therefore quick) compared to the investment required to give the same user full entry rights.
- ◆ How?
  - ◆ User applies to NG for an access right between [node A] and [node B] for a maximum of [x]MW and a duration of [y] years.
  - ◆ NG assess application against current planning baseline with an additional xMW of generation at node A and an additional xMW of demand at node B.
  - ◆ NG offers point-to-point right to user. Offer includes list of reinforcement works triggered.
  - ◆ If user accepts offer, point to point right is only available when reinforcements have been completed. Point to point right is recorded and used in overrun volume calculations and future 'applications' for capacity/exchange rates/point to point rights.
  - ◆ User pays TNUoS differential between node A and node B for y years.