

**Interim Connect and Manage.
Cost Benefit Analysis for the first tranche of connection offers in Scotland,
period 2010/11-2014/15.
National Grid**

Update: 1st July 2010

1. Executive Summary

Interim Connect and Manage (ICM) arrangements were implemented in May 2009 to help connect higher volumes of generation earlier than originally planned prior to enduring transmission connection arrangements being implemented.

The connection of this generation may lead to the transmission system becoming non-compliant with the minimum criteria in the National Electricity Transmission System Security and Quality of Supply Standard (NETS SQSS) and also for the level of constraint costs to rise above their current levels due to the higher volumes of generation behind constraint boundaries.

This document provides a cost benefit analysis (CBA) for additional generation connecting in Scotland for the first tranche of ICM connection offers covering the period 2010/11-2014/15. The work compares the increase in constraint costs associated with the new ICM generation connecting and the carbon benefits associated with such new generation.

This CBA has been undertaken to support Ofgem's assessment of whether it is appropriate to grant derogations for system boundaries B01¹ (system boundary in North Scotland), Kintyre and B06 (system boundary between Scotland and England).

This analysis has considered the total cost impact on these boundaries of establishing these new generation connections. Our analysis suggests that, as we had expected, the total constraint costs for these boundaries will continue to rise over time, driven by the connection of additional generation in advance of wider reinforcement. In this instance, additional constraint costs will be largely offset by the carbon benefit arising from the connection of additional low carbon generation but will in any event reduce once the wider reinforcement works are completed. Furthermore, such costs do not take account of the more qualitative benefits of increased competition which might come from bringing in new entrants, enhanced security of supply and greater certainty of meeting legally binding climate change targets.

There is an ever changing volume of generation looking to connect to the system. Subject to any conditionality in any derogation that Ofgem may grant, National Grid currently anticipates that the analysis contained in this report will be performed on a bi-annual basis to reflect changes to the generation background and to provide Ofgem with updated information.

2. Introduction

In May 2009 Ofgem set out an ICM regime ahead of the enduring Transmission Access Review. The aim of ICM is to accelerate and facilitate the connection of new generation.

¹ B1 and B6 refer to system boundaries as defined in our Seven Year Statement

Ofgem agreed to allow the principle of derogations from NETS SQSS to facilitate the connection of new generation ahead of reinforcement of the wider system.

The framework introduced by ICM will:

1. Allow generation connection dates ahead of the need to complete wider transmission reinforcement works, provided local works required to connect the project can be completed in advance of the wider works.
2. Utilise time limited derogations from the minimum NETS SQSS criteria, that may require NGET to put in place appropriate commercial arrangements to manage the associated impacts e.g. increases in constraint costs.
3. Not discriminate on size of generation nor between new applications and existing generation.

National Grid and the relevant Transmission Owner's (TO) have begun to apply for derogations from NETS SQSS requirements in accordance with this guidance. Due to the timescales for National Grid providing new generation offers to connect, connection offers have in some cases been made ahead of the approval of derogations and therefore offers produced under ICM will be conditional on the derogation being granted by Ofgem. This report supports the submitted and expected derogation requests for the B1, Kintyre and B6 boundaries. The submitted derogation requests are attached in Appendix 1, 2 and 3 of this report for completeness.

This document provides a cost benefit analysis for Scotland for the first tranche of ICM connection offers made for the period 2010/11-2014/15. The work considers the constraint costs incurred by the advancement of generation projects ahead of the wider system works being complete.

As requested by Ofgem we have also included, and separately identified, the impact of embedded generation in assessing the overall impact on system constraints. For example, a 10MW embedded generator has the same impact on constraints as a 10MW transmission connected generator connecting to the same part of the system behind the same constraint boundary.

The use of constraint management contracts and system to generator intertrips are included as a short term method of reducing constraint costs. The cost benefit of allowing the advancement of these projects is also calculated by assuming a carbon benefit achieved by the advanced connection of renewable energy.

This report is provided to support the derogations submitted to Ofgem for the following Scottish boundaries/areas:

Boundary B01.
Kintyre Area
Boundary B06

The division of Scotland by boundary is shown in figure 1.

Figure 1: Boundaries/Areas within Scotland.

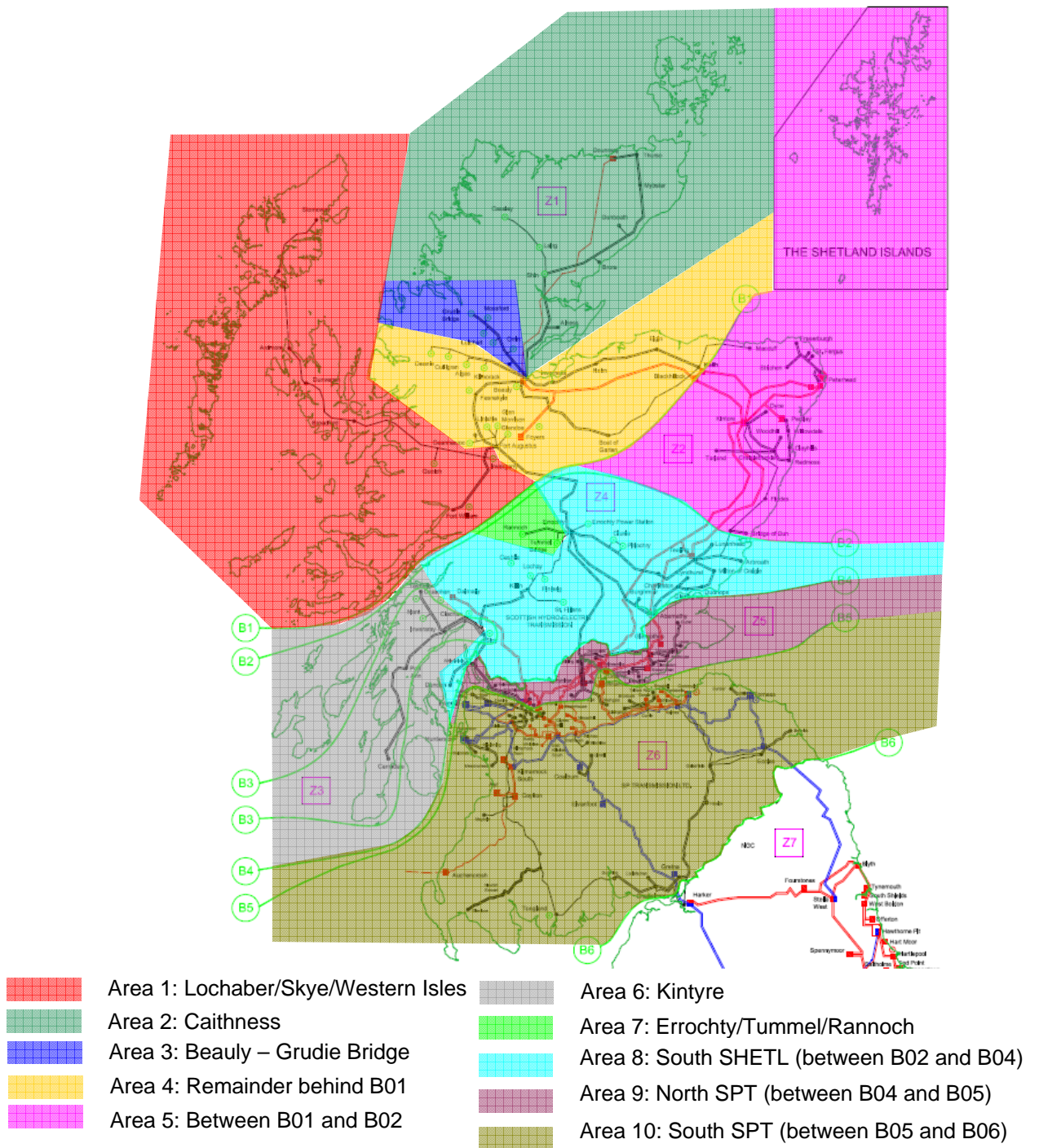

3. Methodology

3.1. Constraint Modelling Methodology

The constraint cost analysis relies on a number of assumptions. These are outlined in the data section which follows in Section 4. The constraint forecast model is based on that used for forecasting the constraint costs for the Balancing Services Incentives Scheme ('BSIS') recently completed for 2010/11², with adjustments to allow for a longer term forecast view.

To assess the incremental volumes of constraints incurred, a contracted background (i.e. all generation with an agreed connection date) was considered alongside a Business as Usual position:

- The contracted background assumes a generation pattern based upon generation that have signed agreements in place with National Grid before 1st November 2009 and with a few adjustments to take into account plant closures for LCPD, such as Cockenzie. The reduced TEC at Peterhead has also been reflected in this contracted background.
- The Business as Usual background includes our view of potential generation closures and incorporates a National Grid view of the potential generation background e.g. what projects will / won't meet their contracted date.

The impact of embedded plant connecting within the distribution networks in Scotland is also assessed. The embedded plant is considered to have connected under the rules of ICM and is included in the assessment of constraint costs due to ICM. For embedded generation, the analysis looks at the aggregated effect that all the small embedded plant has on the boundaries considered in this report (i.e. B01, Kintyre and B06). It is felt that whilst small embedded projects will not individually cause an issue at major boundaries such as B06, the aggregate of a number of these projects may contribute to significant additional constraints on the GB transmission network.

This work complements Connection and Use of System Code (CUSC) amendment proposal CAP167 and associated SO-TO Code (STC) amendment proposal CA031, which seeks to define a Relevant Embedded Small Power Station (RESPS) methodology to enable Distribution Network Operators to assess if embedded generation seeking connection to their network is likely to have a significant impact on the transmission system.

To consider the effect of this generation, they have been represented as a generator source behind each boundary in the constraint forecast model, rather than netting their total from a local demand. The information on the small embedded plant provided by Scottish Power Distribution (SPD) is based on the small generation greater than 1MW, however due to the more radial nature of the Scottish Hydro Transmission Electric

² BSIS is the scheme that incentivises National Grid as National Electricity Transmission System Operator (NETSO) to efficiently manage the costs of operating the GB Transmission System. It is designed to deliver financial benefits to the industry and consumers from reductions in the costs or minimising the risk associated with operating the electricity transmission network.

(SHTEL) network, Scottish Hydro Electric Power Distribution (SHEPD) have provide information on the small embedded plant down to the G83 limits.

The constraint cost model is a cascading model, analysing the impact of new generation on the various cascading boundaries from north to south throughout Scotland. Any generation connections in the north of Scotland will have an impact on the immediate boundary, and if not fully constrained by that boundary will then have an impact on subsequent boundaries as the flow moves southwards.

The constraint cost model analyses the generation impact on all the Scottish boundaries simultaneously to ensure no double counting of constraint volumes and each boundary has its correct allocation of MW constrained and costs associated to it. However, new connections can impact costs on more than one boundary.

The carbon benefits are however allocated to the immediate boundary which the project is connecting behind.

The difference in costs between the baseline and the outlook with embedded generation volumes included gives the incremental costs associated with the connection of embedded generation.

The next step was to look at the change in the forecast constraint costs due to the connection of additional transmission connected generation, large embedded and relevant small embedded generation under the ICM regime. Large generating plant which has expressed an interest in moving to an advanced connection date is brought forward in the analysis. This analysis considers generation which is yet to connect and has a signed agreement as of 1st November 2009 and the small generating plant notified to National Grid by SPD and SHEPD. The large generating plant equates to approximately 370MW and is shown later in this document in table 2a. The relative small generating plant equates to approximately 387MW and is shown later in this document in table 2c and Appendix 5.

4. Modelling Data

4.1. Demand Data

The demand behind each boundary was determined and forecast by considering the relevant distribution company Grid Code submissions for week 24³.

The demand increases year on year has been calculated as follows:

Table1 – Demand Assumption

2010/11	2011/12	2012/13	2013/14	2014/15
Reference	As 2010/11	Reference * 1.0018	Reference * 1.0036	Reference * 1.0072

To produce the constraint cost, yearly demand profiles were applied behind each boundary. The demand data used was based on half hourly demand throughout the year, which has been increased in line with the above figures in table 1 for future years.

³ Week 24 data submissions are provided by Users to National Grid on an annual basis in accordance with the Planning Code in the Grid Code.

4.2 Generation background

For conventional generation, (i.e. gas and coal), this is forecasted using forward price curves to indicate profitable running via the forward spark and dark spreads. When the unit is forecasted to be economic i.e. within the merit order, the running pattern is based on its historical running pattern. Generation outage data is also used to indicate when a generator is not available and hence has zero running during that period.

For hydro and wind, the forecasted running is based on its historical running pattern, again with any generator outage data indicating zero running taken into account.

4.3 Generator Data

Graphs 1, 2 and 3 below show the MW volume of advanced projects and small embedded generation added cumulatively year on year. In later years, some of the advanced projects reach their original compliant connection date and as such are no longer classed as ICM and become part of the baseline.

Plant above 10MW in the SHETL network or above 30MW in the SPT geographical area are classed as large generation (level is 100MW in England and Wales) and are reflected in the contracted background.

Graph 1: Generation added behind Boundary 1.

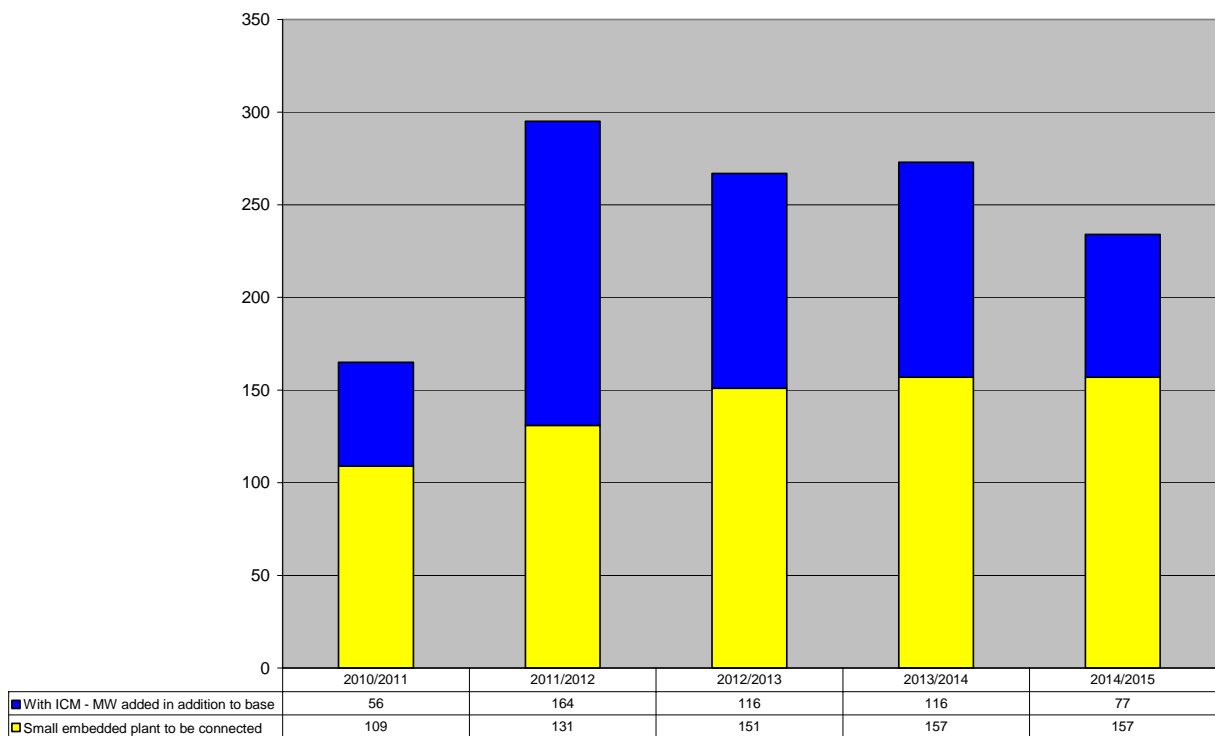

Graph 2: Generation added in the Kintyre Area

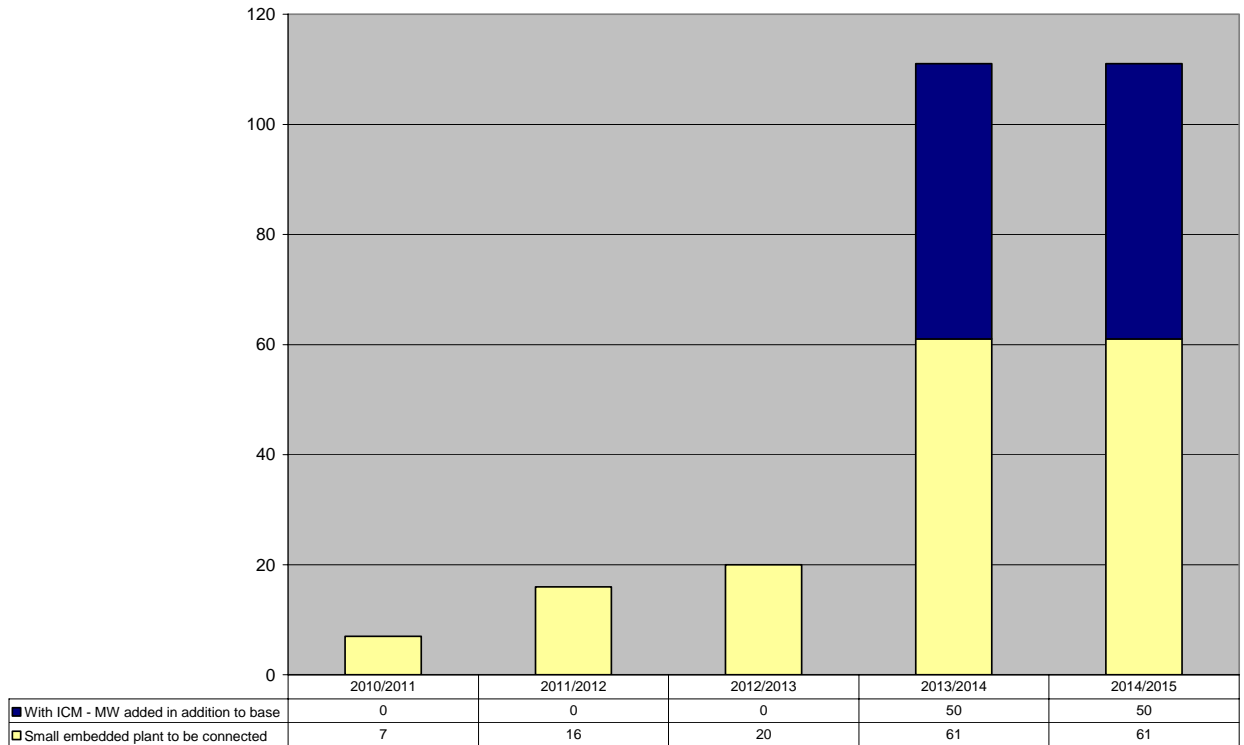

Graph 3: Additional Generation added behind B6 (in addition to the generation connected behind B1 and Kintyre Area)

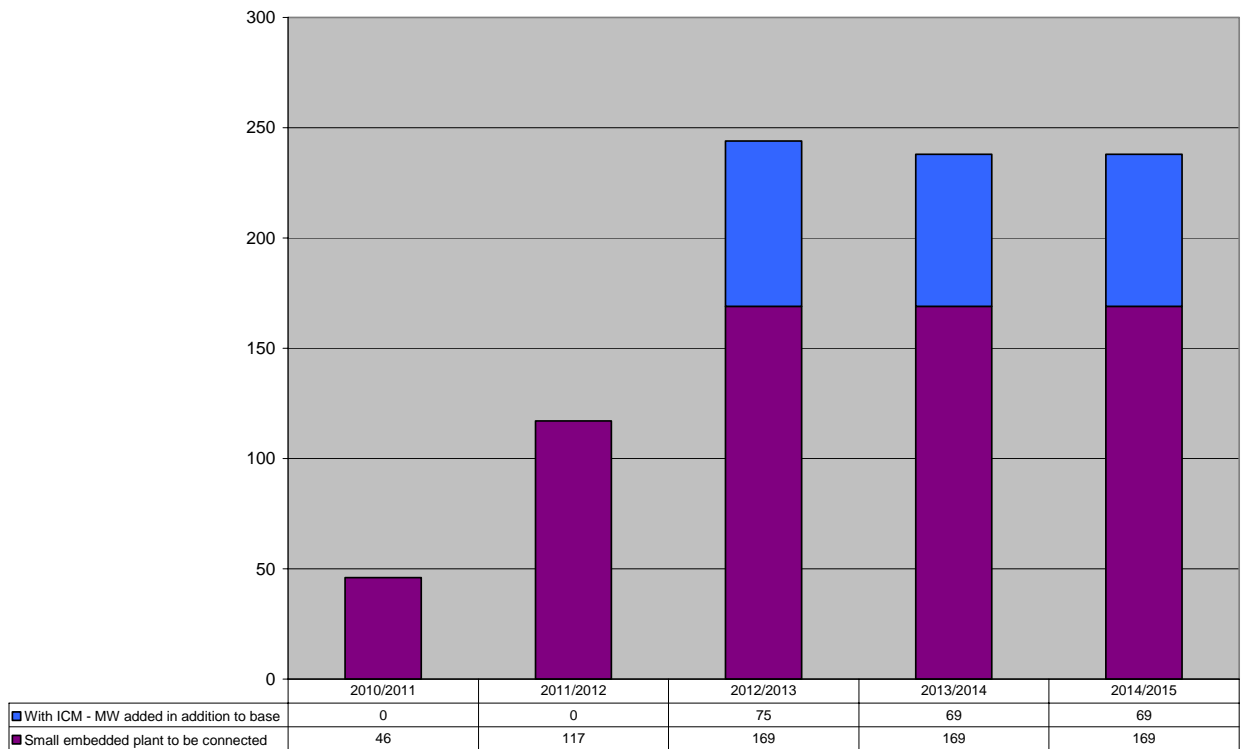

Projects which have advanced contracted connection dates as a result of the ICM regime are listed below in Table 2a.

Table 2a: Scottish Generation Projects Advanced Under Interim Connect and Manage.

Project	Contract	TO	MW	Contracted Completion Date	Advanced Connection Date
Blacklaw WF	BCA	SPTL	69.0	Post 2018	2013
Drummuir	BCA	SHETL	48.3	2016	2011
Glendoe	BCA	SHETL	48.5	2012	2010
Fasnakyle	BEGA	SHETL	7.5	2014	2010
Novar II	BELLA	SHETL	32.0	2014	2011
Mid Hill	BELLA	SHETL	75.0	2013	2012
Rosehall	BCA	SHETL	28.5	Post 2018	2011
Tullo	BELLA	SHETL	3.5	Post 2018	2010
A Chruach	BCA	SHETL	49.9	Post 2018	2013
Total			362.2		

Seven projects, listed below in Table 2b (5 in the SPT area and 2 in the SHETL area, comprising in total around 92MW), have already connected or are about to connect under the framework of ICM.

Table 2b: Projects already connected as a result of ICM.

Project	Year	MW	Transmission Owner
Dargavel	Connected	6.2	SPT
Burnfoot	2010	26	SPT
Drumderg	Connected	4.8	SHETL
Dummuies	Connected	1.85	SHETL
Kaim Hill	Connected	15	SPT
Caledonian Paper Mill	Connected	20	SPT
Glenkerie	2010	18.4	SPT
Total		92.25	

Out of the 5 projects within the SPT area, three have already connected and are accounted for in the week 24 data submitted by SPD; hence they are not explicitly modelled as small embedded plant and are assumed to be netted off demand. The other two projects in the SPT area (Burnfoot and Glenkerie) are expected to connect shortly and are included as part of the small embedded submission by SPD, hence they are accounted for as embedded plant modelled explicitly within this analysis.

The two projects for SHETL represent TEC increases to existing large generating stations and are modelled as part of the baseline.

Small embedded plant connected prior to November 1st 2009 are assumed to have been netted off local demand and accounted for within the week 24 data submissions and thus has not been included explicitly in this model.

The small embedded plant modelled explicitly for this report is given in Appendix 5 of this report and the totals for each area shown in table 2c below.

Table 2c: Total small embedded plant modelled explicitly in each area.

Area	MW
Behind Boundary 1.	156.7
Kintyre Area	61.2
Behind Boundary 6*	169.1
Total	387.0

*but not already accounted for behind the B01 or in Kintyre area.

4.4. Modelling of the Kintyre Region

The analysis was carried out by first splitting the Kintyre region into 3 areas with corresponding critical circuits (Figure 2). This comprises of:

- Area 1 – encompassing Carradale and Port Ann with the two critical circuits being the Inveraray-Eredine Forest and Inveraray-Port Ann circuits
- Area 2 – encompassing Taynuilt with the two critical circuits being the Inveraray-Fernoch and Inveraray-Nant circuits
- Area 3 – encompassing all of Area 1 and 2 including Clachan with the three critical circuits being the Ardkinglas-Sloy/Killin, Inveraray-Sloy and Clachan-Sloy circuits

Figure 2: Division of the Kintyre region.

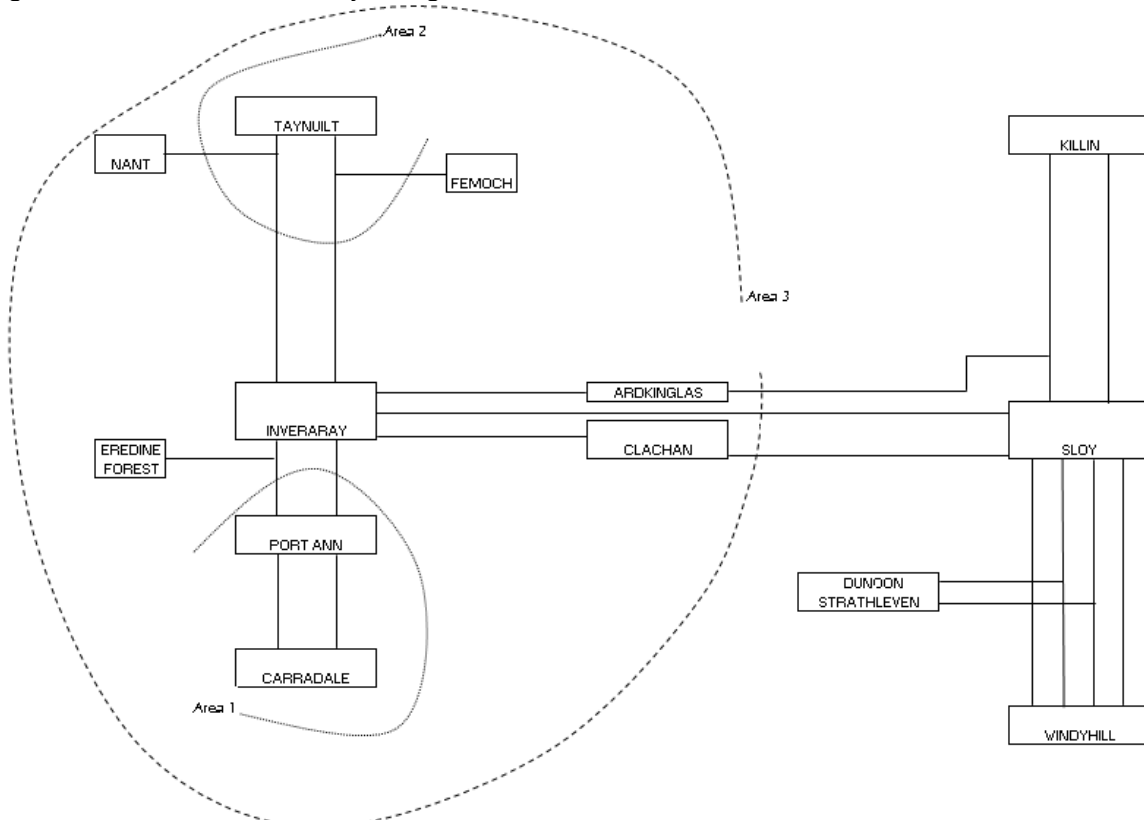

4.5. Boundary Capabilities

Boundary capabilities have been provided by the Scottish Transmission Owners in accordance with Chapter 4 of the NETS SQSS. The boundary limits set by planning criteria have been used for this cost benefit analysis. It is believed that this is a reasonable assumption as we are not able to accurately forecast the operational limits at this stage but can assume they will be similar to the planning limits applied. Planning limits differ from Operational limits when the N-2 planning criterion at winter peak is more onerous than the operational N-D criterion; this is not the case for B1 or B6. They also differ for voltage limits, given different voltage criteria for generalised planning studies versus specific operational conditions; again, neither B1 nor B6 are voltage limits. There are also second-order differences between planning and operational limits, e.g. a planning study with scaled generation may differ from an operational study that has a specific set of generators on full output on and off bars; it is this difference which is not expected to be significant for B1 and B6 in this study.

When managing constraints on the system in real time the limits applied in operational timescales will vary from the limits provided within this report, which are based upon planning criteria. In operational timescales the system operator is able to make use of post fault and short term ratings which will change the limits set for each boundary. On average, we believe this extra freedom is offset by the specific circumstances that the Operator faces such as possible prior transmission outages.

4.5.1. Kintyre boundary limits

The thermal limits used for the Kintyre boundary are shown in Table 3. The demand group behind Kintyre is less than 1500MW and so this group is connected to the main interconnected transmission system by only three circuits (in line with the SQSS). Loss of two circuits with one circuit in outage would disconnect this group from the transmission network.

N-1 capability is the limit of the boundary under intact network conditions following a fault outage of a single transmission circuit. N-1-1 capability is the capability limit where a single transmission circuit is unavailable due to planned outage and we consider the fault outage of another single transmission circuit.

Table 3: Boundary Limits for the Kintyre Boundary.

Demand Data	N-1 Capabilities			N-1-1 Capabilities		
	Winter	Spring/Autumn	Summer	Winter	Spring/Autumn	Summer
Area 1 (Carradale and Port Ann)	99	92	79	N/A	N/A	N/A
Area 2 (Taynuilt)	99	92	79	N/A	N/A	N/A
Area 3 (Inveraray)	252	234	202	126	117	101

4.5.2. B1 Boundary limits with reinforcements

The capabilities of B1 are defined by the loss of a double circuit as set out in Chapter 4 of the NETS SQSS. The limits used on the B1 boundary are shown below in Table 4. The N-D limit is the capability of the boundary without any planned outage on any of the circuits across it. The N-1-D limit is the capability with one planned outage on one of the circuits across the boundary. This represents N-1-D conditions during an outage season, which considers the post fault limit due to a double circuit fault at the time of a single circuit outage.

The different limits in Table 4 are associated with certain boundary reinforcements. These reinforcements generally increase the boundary limit.

Table 4: Boundary Limits for B1.

Season	Outage	2009/10 (with Inverarnan)	2010/11 – 2012/13 (plus Knocknagael)	2013/14 (plus Beaully-Denny)	2014/15 (plus Beaully-Blackhillock)
Summer	N-D	350	360	1150	1800
	N-1-D	215	280	650	1100
Spring /Autumn	N-D	400	430	1200	1800
	N-1-D	220	300	650	1100
Winter	N-D	400	450	1300	1800
	N-1-D	280	320	660	1100

4.5.3. B6 boundary limits with reinforcements

The boundary capabilities for B6 are shown in tables 5. The B6 group is designed to Chapter 4 of the NETS SQSS. The capabilities marked in “*” are adjusted to reflect a stability limit at this boundary.

Table 5: Boundary Limits for B6

Season	Outage	2009/10 – Summer 2012 (pre-reinforcements)	Autumn 2012 - 2014/15 (post-reinforcements)
Winter	N-D	2200*	3300*
	N-1-D	1390	2010
Spring	N-D	1840*	2767*
	N-1-D	1280	1910
Summer	N-D	1660*	2500*
	N-1-D	1110	1750
Autumn	N-D	2020*	3034*
	N-1-D	1280	1910

5. Constraint Costs

5.1 Constraints Cost Model

The results from the constraints costing model are given in section 6. The tables show the total cost of constraints for each boundary against the contracted background and business as usual scenarios; this background model is then used to help determine the incremental cost of the ICM generation using the volumes of generation shown previously.

Using the constraint modelling assumptions in the previous section on generation, demand and boundary capability the model gives us a constraint volume. The forecasting model then determines the most cost effective way to solve the constraints using assumptions on generation constraint contracting strategy, available intertrips and balancing mechanism resolution (i.e. bids and offers).

5.2. Mitigation measures in management of constraint volume

Mitigation measures are being considered to reduce the operational cost of connecting new generation. These can be split into long term and short term measures. In the long term more transmission reinforcement can be completed including line upratings and new circuits to increase boundary capability. Short term measures will include operational tools including BM actions, contracts to manage generation output and operational intertrips.

Long term mitigation measures are the responsibility of the respective transmission owner although any reinforcements need to be justified against the relevant operational cost.

Intertrips to be considered include hard and soft schemes. The hard intertrip will provide reduction of generator output to zero in very short timeframes and can be used to support the system where stability is an issue. Where there is a thermal limit a soft intertrip may be employed. The soft intertrip will utilise the 3 minute rating of circuits to allow for a fast deload of generating plant. This is particularly valuable for technologies such as wind where an immediate disconnection may result in damage to turbines.

For the B6 Cheviot boundary the intertrip has been extended to include the additional generation that NGET has contracted with since February 2009 and the boundary capability has been increased by strategic reinforcement works. National Grid continues to actively try to secure additional services from all relevant generator providers.

Proposals such as CAP170 (which proposes to extend the existing administered prices for intertrips under CUSC governance) will help to reduce constraint costs if implemented. This analysis does not assume the use of CAP170.

5.2.1 Quantifying the Effect of Contracts and Intertrips in Reducing Constraint Costs

National Grid is working to reduce constraint costs by putting in place constraint management contracts with generating companies to manage their generation output over periods of system constraints.

The analysis undertaken for this report includes the use of constraint management contracts and system to generator intertrips to manage constraint costs. The assumption of the volume of constrained generation managed by constraint management contracts is as follows:

- 80% of generation is managed with constraint management contracts. This is presumed to be a lower cost than alternative i.e. management in the BM. 20% of constraint volume is managed in the BM. There is a contracting premium of £15/MWh over the dark/spark spread for contracts that apply from April through and including October. There is an assumption that there is no constraint contracting through the Winter Months.

The intertrip assumption presumes that current arrangements are still available.

The Wind bid price has been assumed at a ROC (Renewable Obligations Certificate) price of -£50/MWh. This is the highest price assumption of wind. If wind can not be pulled back at this level, constraint costs are expected to rise.

5.3 Cost-Benefit

The cost benefit analysis compares the cost of constraints discussed above with the carbon benefits of advancing the connection of new generation. The carbon benefit is given as the benefit attributed to ICM connected generation behind each boundary. This allows a comparison with the incremental constraint costs given.

This carbon benefit is simply identified, using the following assumptions:

- New renewables will generate at a price cheaper than the likely marginal gas or coal generation price in the mid 2010s, and so give a benefit of reducing electricity prices. This benefit is treated as a qualitative benefit only and has not been quantified for inclusion in the analysis since the fuel price benefit accrues to the station developers, who offset it against the capital costs and the risks of building the stations.
- New renewables give national benefits on diversity of energy supply. Given the wide-scale nature of such benefits, it is not appropriate to quantify these arguments for use in the cost-benefit analysis.
- New renewables will provide a carbon benefit, derived from the displacement of an equivalent capacity of conventional generation. DEFRA's medium-term advice for carbon benefit has been applied such that incremental generation in the medium-term can be assumed to be gas-sourced, at a carbon impact of 0.43 T_CO2/MWh. Hence per MW of new Wind capacity:

Generation of 1MW of Wind at 32% load factor = 1MW x 0.32 x 8760hr
= 3.0 GWh;

Carbon Benefit = 3 GWh x 0.43 kT_CO2/GWh = 1.29 kT_CO2;

Carbon Benefit = 1.29 x 22.5 £/T_CO2 = **£29k per MW per year**

- We have applied the DECC advice, as per "Carbon Appraisal in UK Policy: a Revised Approach" (2009). Since our advancements are across years 2010-2014, we have used the average of the recommended Trading price of Carbon across those years, namely 22.5 £/T_CO2. In November 2006 Stern stated that, over the medium term, carbon needs to be priced at around \$80/T_CO2 in order to meet a world-wide target of 60% carbon reductions by 2050. However, such high carbon prices are not considered in this analysis. It is also noted that the traded price for carbon, under the ETS across the years 2008 to 2012, has fallen from around 20 £/T_CO2 to around 10 £/T_CO2 over the second half of 2008. However, such a low price of Carbon is considered unsuitable for use in this medium-term appraisal.

6. Results from the Cost Benefit Analysis.

This section attempts to show the impact of advanced projects and small embedded projects upon future constraint costs. For each boundary subject to a derogation application, two tables are presented – one for Business as Usual and one representing the revised contracted connection dates offered through ICM. The tables show the following:

- **Costs for boundary baseline:** These are the background constraint costs that are forecast to occur with the network as now (i.e. either compliant with NETS SQSS or as already derogated).
- **Additional costs due to small embedded/ICM increment:** These are the additional constraint costs caused by the advancement of small embedded or large embedded and transmission-connected ICM plant. These connections will cause the boundaries to be non compliant, or increase existing non-compliance, and hence a derogation has been submitted to reflect and manage this non compliance.
- **Carbon Benefit of ICM Projects (including embedded):** This is calculated in line with the principles set out in section 5.3.

Table 6: Costs for the B1 Boundary to reflect the addition of small embedded and ICM Projects-Contracted

Contracted. B1 Background	2010/11	2011/12	2012/13	2013/14	2014/15
	£k	£k	£k	£k	£k
Costs for B1 Boundary. Baseline	3,289	1,884	2,119	459	248
Additional Costs due to Small Embedded	160	518	992	237	2
Additional Costs due to ICM increment	576	1,974	2,269	640	6
Carbon benefit of ICM Projects (including embedded)	4,736	8,491	7,711	7,863	6,942

Table 7: Costs for the B1 Boundary to reflect the addition of small embedded and ICM Projects-Business as Usual.

Business as Usual. B1 Background	2010/11	2011/12	2012/13	2013/14	2014/15
	£k	£k	£k	£k	£k
Costs for B1 Boundary. Baseline	1,700	1,966	1,316	643	123
Additional Costs due to Small Embedded	1,282	917	3,995	240	33
Additional Costs due to ICM increment	1,838	1,893	934	746	37
Carbon benefit of ICM Projects (including embedded)	4,736	8,491	7,711	7,863	6,942

Table 8: Costs for the Kintyre Boundary to reflect the addition of small embedded and ICM Projects-Contracted View.

Contracted. Kintyre Background	2010/11	2011/12	2012/13	2013/14	2014/15
	£k	£k	£k	£k	£k
Costs for Kintyre Boundary. Baseline	50	120	116	139	133
Additional Costs due to Small Embedded	0	49	50	266	446
Additional Costs due to ICM increment	0	0	0	1,026	1,830
Carbon benefit of ICM Projects (including embedded)	197	477	567	3,212	3,212

Table 9: Costs for the Kintyre Boundary to reflect the addition of small embedded and ICM Projects-Business as Usual.

Business as Usual. Kintyre Background	2010/11	2011/12	2012/13	2013/14	2014/15
	£k	£k	£k	£k	£k
Costs for Kintyre Boundary. Baseline	49	71	61	84	66
Additional Costs due to Small Embedded	0	40	45	234	347
Additional Costs due to ICM increment	0	0	0	776	1,408
Carbon benefit of ICM Projects (including embedded)	197	477	567	3,212	3,212

Table 10: Costs for the B6 Boundary to reflect the addition of small embedded and ICM Projects-Contracted View.

Contracted. B6 Background	2010/11	2011/12	2012/13	2013/14	2014/15
	£k	£k	£k	£k	£k
Costs for B6 Boundary. Baseline	79,500	176,426	89,208	61,914	113,654
Additional Costs due to Small Embedded	3,588	11,880	14,514	13,087	25,801
Additional Costs due to ICM increment	9,628	23,862	14,168	15,948	16,091
Carbon benefit of ICM Projects (including embedded)	3,344	5,400	9,063	10,760	10,760

Table 11: Costs for the B6 Boundary to reflect the addition of small embedded and ICM Projects-Business as Usual.

Business as Usual. B6 Background	2010/11	2011/12	2012/13	2013/14	2014/15
	£k	£k	£k	£k	£k
Costs for B6 Boundary. Baseline	55,697	122,451	58,924	31,469	55,925
Additional Costs due to Small Embedded	5,801	12,977	10,436	9,649	15,292
Additional Costs due to ICM increment	9,070	16,827	9,155	10,306	15,010
Carbon benefit of ICM Projects (including embedded)	3,344	5,400	9,063	10,760	10,760

Table 12: Total Costs for Scotland for a Contracted Background.

Contracted. Total for Scotland	2010/11	2011/12	2012/13	2013/14	2014/15
	£k	£k	£k	£k	£k
Baseline	82,839	178,430	91,443	62,512	114,035
Additional Costs due to Small Embedded	3,748	12,447	15,556	13,590	26,249
Additional Costs due to ICM increment	10,204	25,836	16,437	17,614	17,927
Carbon benefit of ICM Projects (including embedded)	8,277	14,368	17,341	21,835	20,914

Table 13: Total Costs for Scotland for a Business as Usual Background.

Business as Usual. Total for Scotland	2010/11	2011/12	2012/13	2013/14	2014/15
	£k	£k	£k	£k	£k
Baseline	57,446	124,488	60,301	32,196	56,114
Additional Costs due to Small Embedded	7,083	13,934	14,476	10,123	15,672
Additional Costs due to ICM increment	10,908	18,720	10,089	11,828	16,455
Carbon benefit of ICM Projects (including embedded)	8,277	14,368	17,341	21,835	20,914

7 Discussion from Observed Results

In general terms there is seen to be an increase in constraint costs from the connection of small embedded projects and the advancement of projects under ICM. There is also a positive carbon benefit from the connection of this new renewable plant.. For the Kintyre and B1 boundaries the total carbon benefit is greater than the additional cost of constraints associated with those boundaries. However, when considering Scotland as a whole, the overall cost of constraints is higher than the corresponding carbon benefit.

7.1. The B1 Boundary

There is significant generation activity in this zone against a network which is limited in size and capability. Over half of the ICM projects considered in this analysis appear behind the B1 boundary as shown in table 1. Graph 1 shows there is significant embedded generation forecast to connect and that the aggregate of small embedded projects under 10MW in size contributes over 100MW to the embedded total in all years. The results tables show that although there are constraint costs associated with the new embedded generation and ICM projects, improved thermal limits resulting from reinforcement works give an overall decrease in constraint costs over the period of this analysis. Also, the carbon benefit costs from connecting the new ICM and embedded plant is greater than the forecast constraint costs. Note however that the capability of this boundary and hence the associated costs are very sensitive to slips in the construction programme.

7.2. The Kintyre Boundary

The advancement of plant due to ICM shows that this boundary is vulnerable in the future to any increases in connected generation. Many of the embedded generation projects in this area are less than 1MW but when totalled together can be seen to have a significant impact on the constraint costs.

Constraint costs for the large ICM projects rise in 2013/2014 as a result of the connection of A Chruach. SHETL are now looking to progress reinforcement work triggered by this connection, as the most cost effective solution for the industry. The reinforcement work will improve the boundary capability of Kintyre and will reduce the constraint costs outlined in this report.

7.3. The B6 Boundary.

For B6 we see a significant rise in costs for 2011/2012 as additional wind appears, as no improvements to the boundary limit occur until summer of 2012. In 2013/14 we see overall costs reduce as the boundary limits increase; constraint costs then start to increase again as additional wind connects.

The constraint costs for this boundary are significant and larger than the carbon benefit from connecting the renewable plant in this zone. The SYS diagrams in Appendix 4 show that the B6 boundary is currently non compliant, so baseline costs are high for this boundary. As the constraints model provides year round costings, some of the constraints seen on B6 will be as a result of advanced connections behind the other boundaries, as these will contribute to the power flow from north to south. As thermal limits improve on boundaries further north less plant will need to be constrained at boundaries such as B1, but will still contribute to higher power transfers across the B6 boundary.

7.4. Total Costs for Scotland

Under the present modelling techniques it is possible to aggregate the constraint costs for each boundary and to consider the total benefit of ICM within Scotland (tables 12 and 13 above). The total constraint costs for Scotland are seen to be rising over time. These costs can be managed by transmission reinforcement in the longer term and by the use of constraint contracts and other commercial tools in the shorter term (the analysis reflects these mitigating measures for managing constraint costs moving forward).

The overall costs of constraints are higher than the carbon benefit and this reflects the high level of connection activity within Scotland. The costs portrayed for ICM are the additional costs which are incurred as a result of non compliance in Scotland against the NETS SQSS.

8. Limitation of Constraint Modelling and Assumptions

National Grid is continually looking to improve the forecasting techniques used. As modelling and forecasting ability improves, the results from these studies may alter. Modelling enhancements will be reflected in the biannual review of constraint forecasting for submitted derogations.

There are limitations in the economic assessment contained within this report and these are outlined below:

1. Generation regimes/outputs into the future can be different due to commercial or technical unavailability and there is uncertainty in fuel availability (e.g. intermittent nature of wind)
2. The outage programme has more uncertainty as we move into the future. For the purpose of this analysis the following outage patterns have been assumed from 2011/12 onwards:
 - B1 boundary, 15 weeks of outages
 - Kintyre area, 4 weeks of outages
 - B6, 25 weeks of outages

During periods of outage on the transmission network the capability of the associated network boundary is reduced, as seen in tables 3 through to 5. It is therefore expected that during the outage season constraint costs will increase as the boundary limits are reduced.

The generic outage pattern for the B01 boundary above can be considered optimistic in view of the works which are proposed to reinforce this boundary. Constraint costs may be seen to rise in the future as National Grid obtains more information about future works and outage patterns.

The generic outage pattern for the B06 boundary above can be considered pessimistic in the later years once the proposed reinforcements to this boundary have been completed. Constraint costs may be seen to reduce in the future as National Grid obtains more information about future works and outage patterns.

3. Boundary transfers depend heavily on location of generation within an area and become more uncertain as we look further out into the future. Boundary capabilities will change if reinforcement work is delayed or other issues, such as stability, are identified at a boundary.
4. If demand decreases in an export constraint group the power flow across a boundary will increase and more constraints may need to be managed. All boundaries considered within this report are export boundaries.
5. There is financial uncertainty in the forward prices. This impacts the bids and offers taken to resolve the constraints. The marginal machines used to replace the constrained MW and the other mitigation measure e.g. intertrips.
6. This analysis assumes that it will be possible to secure a large number of contracts with generating companies.

9. Comparison with BSIS forecasts.

This constraint analysis was completed using the same basic model as that used to develop the 2010/11 BSIS constraint forecast. The input assumptions have been used in line with this report to present a view which looks further into the future and which aligns with the derogation requests.

The ICM model looks at constraints at B01, Kintyre and B06 only whereas the BSIS model considers other internal Scottish boundaries. This approach can have a significant impact on the constraints forecast, particularly it is believed for B01. In the BSIS analysis a boundary known as B00 exists, which is considered to be the network above Beaully substation. If a limit is imposed upon the B00 boundary then plant will be pulled back to make this boundary compliant. This boundary has a limited number of export circuits so a limit at this point on the system can significantly increase the cost of constraints in this part of the network. This generation is almost all wind which has a high pullback price compared to conventional generation. In this current analysis, this B00 boundary has been ignored and plant is only constrained at the B1 boundary where there is a higher thermal limit and more plant to manage constraints. It is intended that once more information becomes available; the B00 boundary will be modelled in detail and assessed in future reports.

The ICM model only considers the boundaries at which the Scottish TO has requested a derogation. A review and discussion of compliance and requested derogations will take place at least bi-annually.

Whilst using the same model as BSIS, this analysis is based upon a different set of long term planning assumptions as described within this report. The constraint numbers are provided to try and establish a cost benefit associated with advancing projects under ICM only. The constraint costs can not be considered as a longer term BSIS forecast and are expected to see more change over time due to the generic assumptions used and the uncertainties which have been modelled.

10. Conclusion.

This analysis has been provided to help Ofgem determine whether the derogations for boundaries B1, Kintyre and B6 are to be approved. This analysis is valid for the set of assumptions used at the end of 2009 and based on data frozen at November 1st 2009. Since November a number of new projects, some significant in size, have applied within Scotland and have signed applications to connect under the ICM regime. Following consideration of this report by Ofgem this analysis will be repeated to capture the changes in the generation.

In the longer term it is proposed to repeat the constraint analysis biannually to reflect changes to the generation background and to provide Ofgem with updated economic figures. This review will also re-examine outage information and check the progress of strategic reinforcements.

APPENDIX 1: B1 Derogation Submitted to Ofgem.

Relevant Paragraph(s) of GB Security and Quality of Supply Standard	CAUSE	PART OF SYSTEM AFFECTED	INITIAL CONDITIONS		INTERIM OPERATIONAL SOLUTION	LONG TERM SOLUTION	COMMENTS
			SYSTEM INTACT	CIRCUIT OUTAGE			
<p>GBSQSS Section4 Clauses 4.4 to 4.10</p>	<p>Double Circuit Fault Outage Of 275 kV B01 circuits to the west of Blackhillock;</p> <p>BA1-AH1/HO2</p> <p>Single Circuit Fault Outage on 132kV between Fort Augustus and Errochty.</p> <p>EF1/EF2</p> <p>Single Circuit Fault Outage on 132kV between Beauly and Inverness.</p> <p>BIN/BNS</p>	<p>B01 boundary ccts comprising;</p> <p>(i) 275kV double circuit between Beauly and Blackhillock (BA1/AH1) and between Foyers and Blackhillock (HO2). (ii) 132kV double circuit between Fort Augustus and Errochty (EF1/EF2) (iii) the two SGTs at Keith.</p> <p>Critical faults are;</p> <p>(i) 275kV double circuit between Beauly and Blackhillock (BA1/AH1) and between Foyers and Blackhillock (HO2), causing overload on 132kV parallel network between Beauly and Inverness.</p> <p>(ii) 132kV single circuit fault between Fort Augustus and Errochty causing an overload on remaining circuit.</p> <p>(iii) 132kV single circuit fault between Beauly and Inverness causing an overload on remaining circuit.</p>	<p>System intact at ACS peak demand.</p> <p>System conditions expected to arise in course of a year</p>	<p>None</p> <p>Typical planned outage patterns</p>	<p>GBSO operational measures in operational timescales in accordance with Section 5 of GBSQSS</p>	<p>SHETL to develop and construct the following transmission reinforcements;</p> <p>Knocknagael S/S (2011*) Beauly-Denny (2013*) Beauly-Blackhillock-Kintore reconductoring (2014*)</p> <p>* Completion dates subject to consents and regulatory approval.</p>	<p>Derogation is sought until completion of listed long term reinforcement solutions.</p> <p>This derogation has been triggered due to advancing generator connections under the interim connect and manage arrangements introduced May09</p> <p>(details of generation provided in cost benefit analysis).</p>

Background to the network demand and generation.

In order to advance the proposed generation connections to the north of SHETL's North West boundary (B01), SHETL require a derogation against the planning criteria in clauses 4.4 to 4.10 of Section 4 of the GBSQSS. In seeking this derogation it is expected that National Grid will continue to comply with its obligations to operate the transmission network in accordance with the operational security standards outlined in Section 5 of the GBSQSS.

The GBSQSS Section 4 sets out the deterministic criteria to be complied with in planning timescales. These require assessment of the intact transmission system at ACS peak demand for various fault contingencies.

The Phase Shifting transformers located at Errochty on the 132kV circuits between Fort Augustus and Errochty can be set up pre-fault to optimise the post fault flows on the circuits to the south and east of Beauly. This has improved the sharing of power flows on these routes such that the boundary limit can be triggered by three separate fault contingencies.

The three critical fault contingencies which limit the transfers across the B01 boundary are as follows;

- (i) Loss of the 275kV double circuit between Beauly and Blackhillock (BA1-AH1) and between Foyers and Blackhillock (HO2), causing overload on the 132kV circuits between Beauly and Inverness or the 132kV circuits between Fort Augustus and Errochty.
- (ii) Loss of a 132kV single circuit on the overhead line between Fort Augustus and Errochty, causing overload on the remaining circuit on the same route.
- (iii) Loss of a 132kV circuit on the overhead line between Beauly and Inverness, causing overload on the remaining circuit on the same route.

Section 4 also requires consideration of the year round conditions including demand cycles, typical power station operating regimes and typical outage patterns to determine if operational measures are economic compared to investment in transmission capacity.

SHETL's North West (B01) Boundary Transmission System as of June 2009

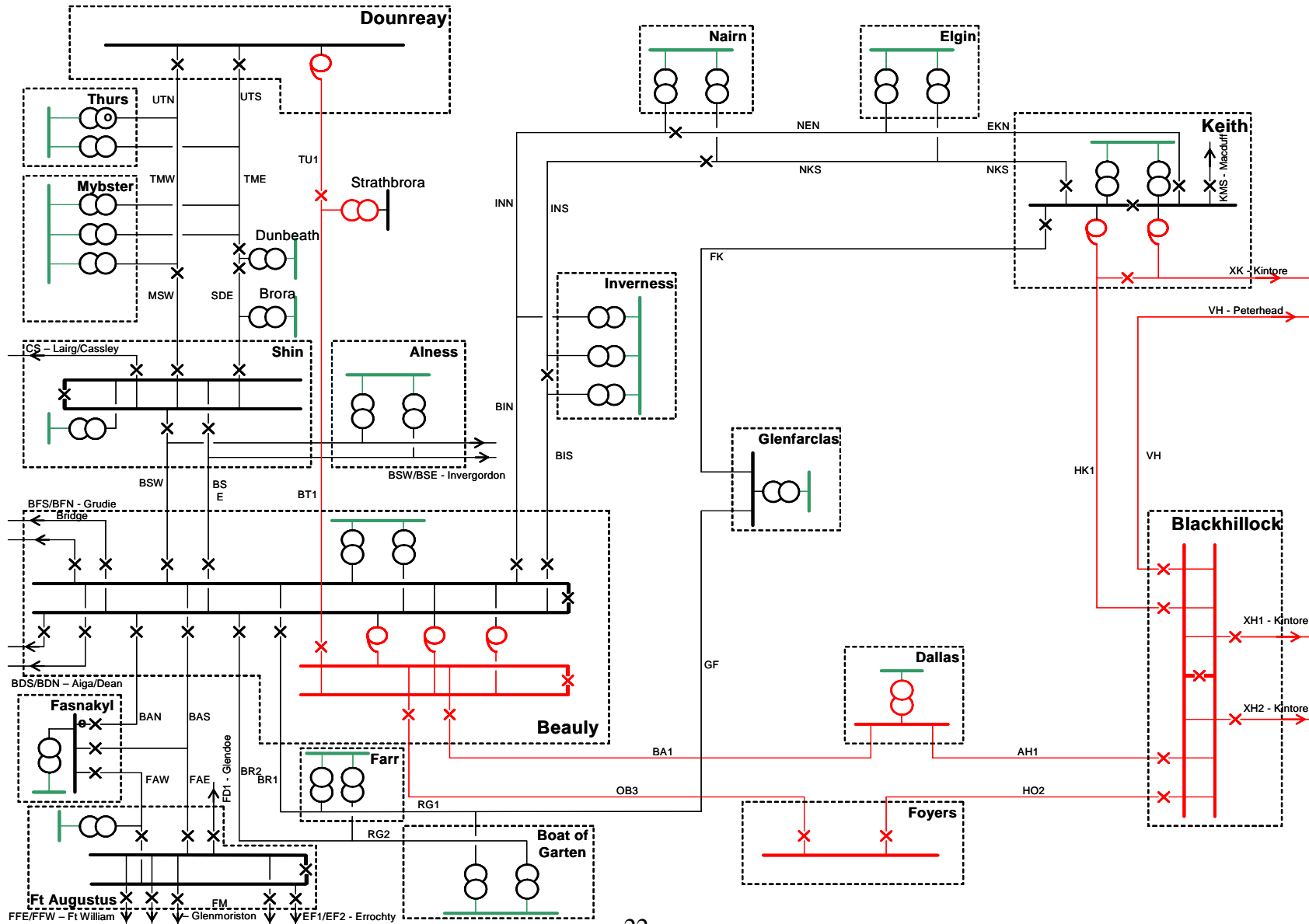

Impact assessment of the non-compliance						COMMENTS
Consumers	Security of Supply	Competition	Sustainable Development	Health and Safety and the associated risk management measures	Other Parties Affected	
<p>During the derogation there may be an increase in operational constraints and therefore operational costs, however there should not be any impact on the security of supply to consumers.</p>	<p>During the derogation period, the GBSO will continue operate the system in accordance with operational security standards (Section 5 of GBSQSS).</p> <p>This may result in increased operational constraints and therefore operational costs, however there should not be any impact on the security of supply.</p>	<p>The interim connect and manage arrangements will allow early access of generation to the network in advance any required wider transmission reinforcement works. This should facilitate competition in generation.</p>	<p>SHETL to develop wider transmission reinforcements as a permanent solution to address the non-compliance. These reinforcements include;</p> <p>Knocknagael Substation</p> <p>Beaully-Denny</p> <p>Beaully-Blackhillock-Kintore reconductor</p>	<p>National Grid and SHETL will ensure that health and safety are not compromised during the derogation period.</p>	<p>There are no other parties directly affected</p>	

APPENDIX 2 – B6 (Scotland - England Transmission Interconnection) Derogation Submitted to Ofgem.

Relevant Paragraph(s) of GB Transmission System Security and Quality Standard	CAUSE	PART OF SYSTEM AFFECTED	INITIAL CONDITIONS		INTERIM OPERATIONAL SOLUTION	LONG TERM SOLUTION	COMMENTS
			SYSTEM INTACT	CIRCUIT OUTAGE			
Design of Main Interconnected Transmission System – Paragraphs 4.1 - 4.13	Introduction of BETTA and the impact of access arrangements given to Scottish users/applicants under standard license condition C18	Scotland - England boundary transmission circuits: Eccles - Stella West and Strathaven - Harker (and relevant 132kV circuits from Galashiels)		Unacceptable overloading of remaining circuits (under Planned Transfer plus appropriate Interconnection Allowance)	Application of pre-fault constraints to generation in Scotland to permit compliance with Section 5 of the GB SQSS (Operational Standards)	Upgrading of transmission capability between Scotland and England as detailed below.	It is expected that the sanctioned works detailed below will be complete by 31 st October 2011. It is also anticipated that further works will be required to fully restore compliance after completion of these reinforcements. A derogation is requested until 31 st March 2012 to align with the end of the PCR Period. The outcome of this PCR will determine the most efficient implementation of the two final stages of the strategy outlined below. Revision of GBSQSS to clarify treatment of wind generation may have the effect of increasing/reducing Required Capability.

The existing Scotland-England Transmission Interconnection is shown in Figure 1. The maximum capability of this configuration is 2.2GW. In late 2006 NGET sanctioned a staged strategy to increase the capability of the Scotland-England Transmission boundary. Specific network reinforcements associated with the initial stages of the strategy were also sanctioned involving the following projects:

- Completion of the works on the Interconnector circuits between Scotland and England to increase the transmission capacity to 2.8GW. These works are currently part of NGET's licence and should be completed by 2010.
- Completion of Heysham Ring reconductoring and upgrade of the existing 275kV route between Stella West and Norton to 400kV. These works will increase the capability to 3.3GW and are due for completion in October 2011.

The sanctioned reinforcements are further detailed in Table 1 and the network configuration following these reinforcements is shown in Figure 2. The Anglo-Scottish transmission capacity is anticipated to be non-compliant with the GBSQSS on completion of the above projects (Fig 3 refers).

To restore full compliance National Grid will continue to engage in analysis and research for alternative transmission methods to identify the most appropriate option to increase the capability beyond 3.3GW. Budget submissions from three suppliers show that conventional AC reinforcements are still the most cost-effective option. However, on and offshore HVDC transmission is currently undergoing attractive developments with costs for HVDC solutions being reduced. These solutions will therefore be evaluated further as HVDC installations could require less complex consents and wayleave acquisitions compared to conventional AC assets.

Figure 1: Scotland – England Interconnector: Existing Configuration

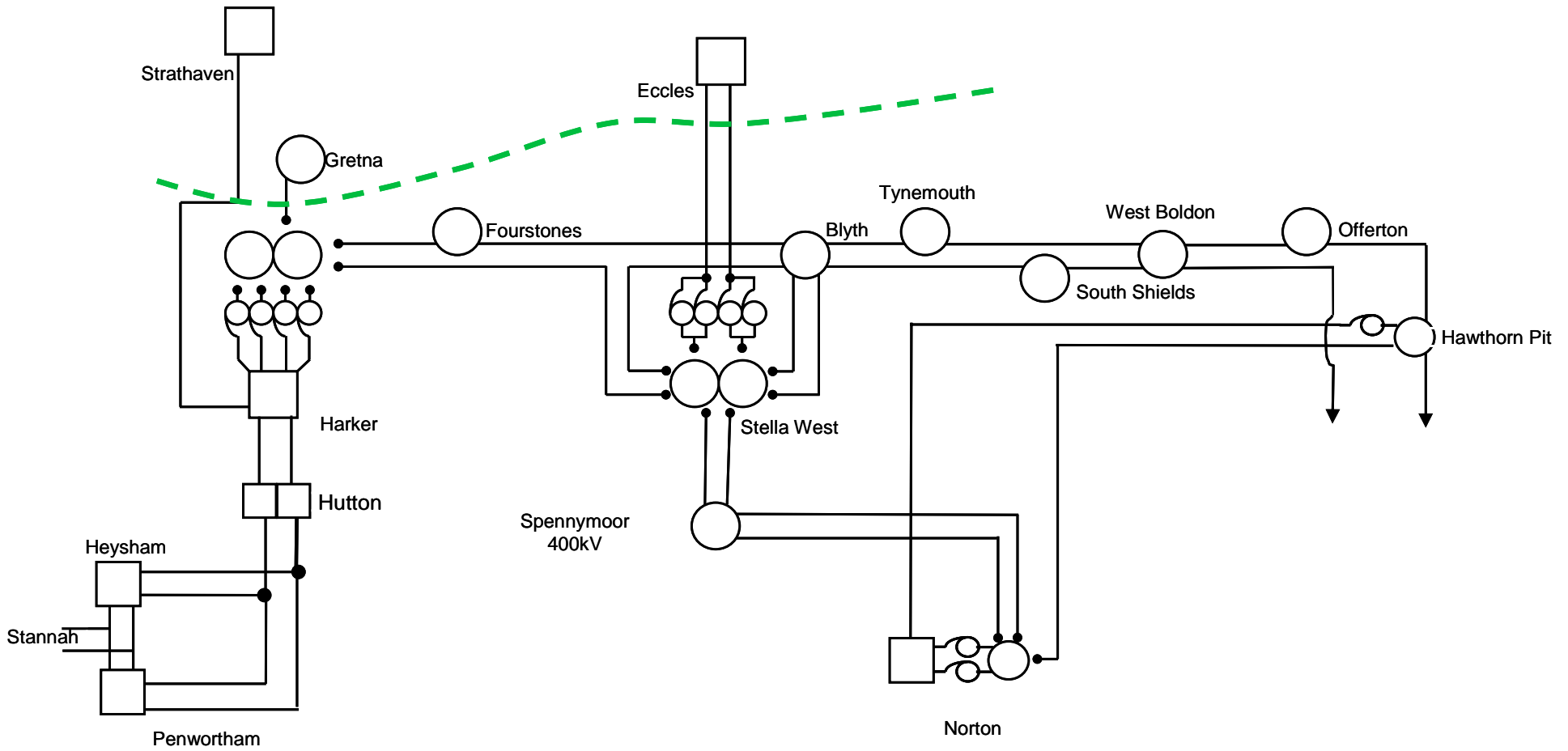

Figure 2: Scotland – England Interconnector: Configuration by 2012 (upgrades shown in blue).

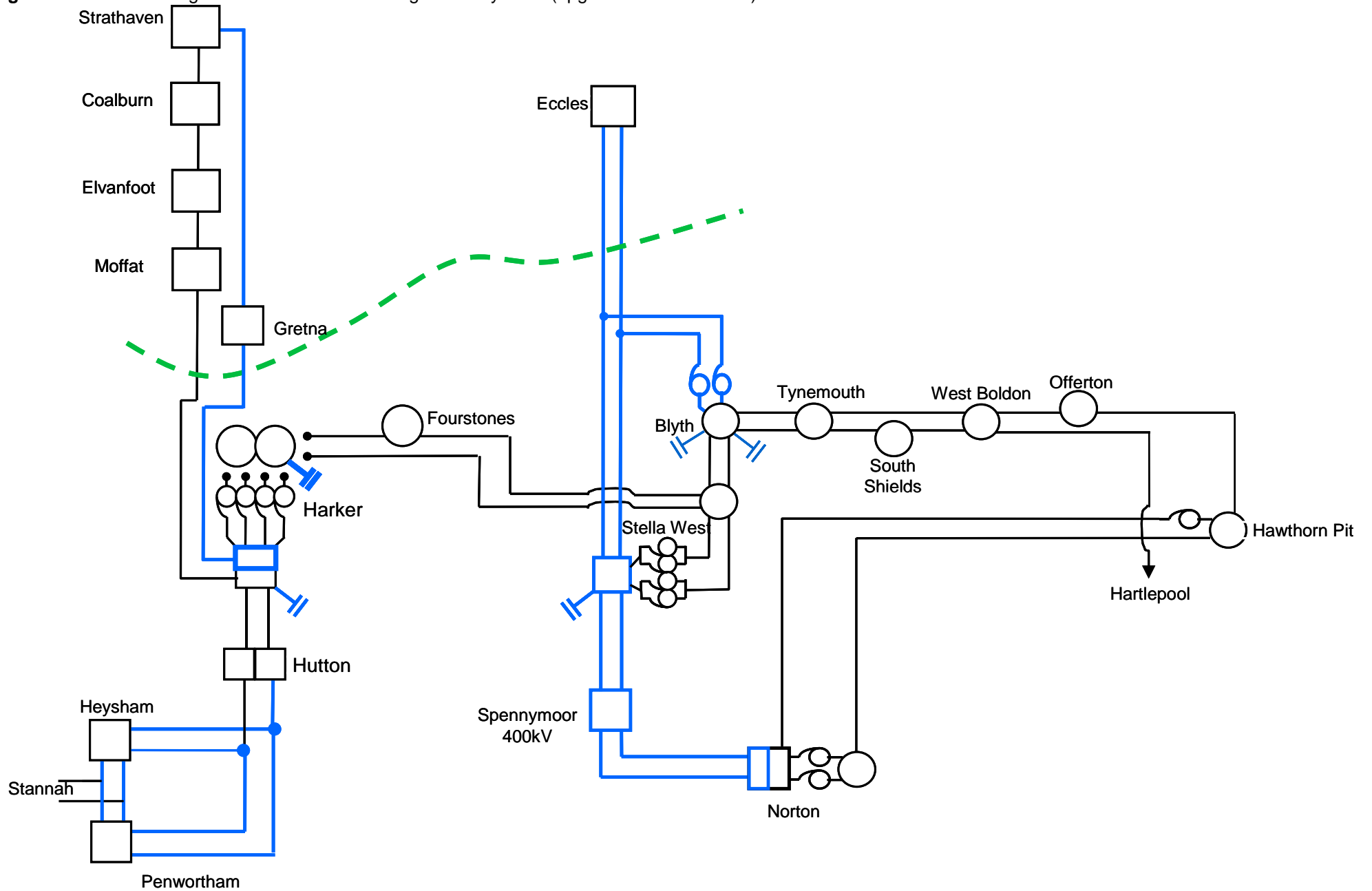
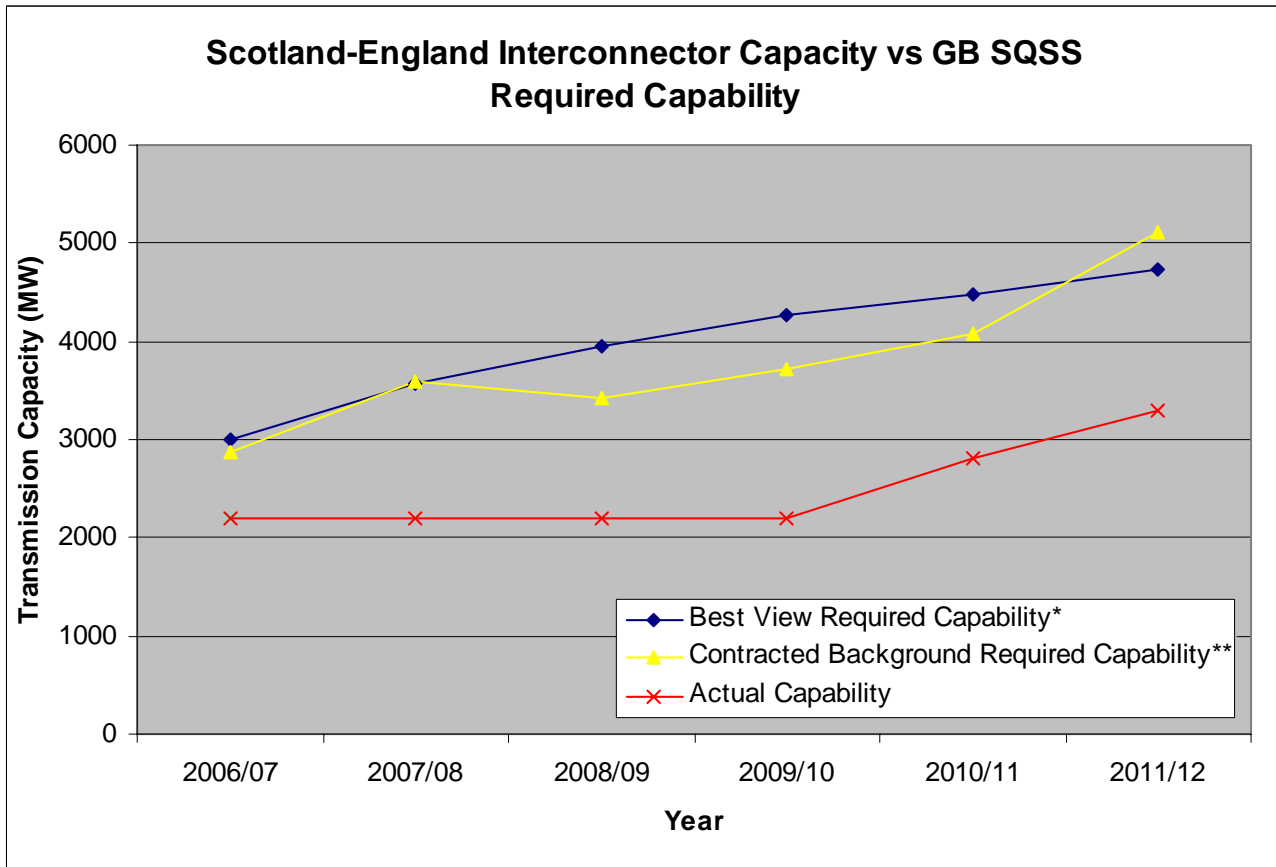

Figure 3: GBSQSS Required Capability of the Scotland-England boundary based on the Contracted and National Grid's Business as Usual generation backgrounds plotted against the boundary capability following sanctioned network reinforcements.



*Date from the June 2006 Investment Planning background

**Data from the SYS 06 (January 2007 update) background

Table 1: Timing of Reinforcements and their Effect on Transfer Capability.

	2006/07	2007/08	2008/09	2009/10	2010/11	2011/12
Boundary Capability	2200	2200	2200	2200	2800	3300
Reinforcements				Western interconnector & Heysham Ring upgrades	Eastern interconnector upgrade	Upgrade of Stella West to Norton DC to 400kV
MSCs		1x150 @ Harker 275kV 2x150 @ Blyth 275kV	1x225 @ Harker 400kV		1x225 @ Stella West 400kV	1x225 @ Harker 400kV

APPENDIX 3: Kintyre Derogation

Relevant Paragraph(s) of GB Security and Quality of Supply Standard	CAUSE	PART OF SYSTEM AFFECTED	INITIAL CONDITIONS		INTERIM OPERATIONAL SOLUTION	LONG TERM SOLUTION	COMMENTS
			SYSTEM INTACT	CIRCUIT OUTAGE			
GBSQSS Section2 Clauses 2.5 to 2.13	<p>Double circuit fault outage of 132 kV circuits to the west of Sloy; ISN/ICS-CSS</p> <p>Single circuit fault outage on 132kV circuits to the west of Sloy during pre-planned single circuit outage on same circuits: ISN/ICS-CSS/IK1-KS1-SN1</p> <p>Single circuit fault outage on 132kV circuits between Inveraray and Carradale: IPW-PCW/ IPE-PCE</p> <p>Single circuit fault outage on 132kV circuits between Inveraray and Taynuilt: ITW/ITE</p> <p>Bus section fault outage at Inveraray 132kV Substation</p>	<p>South West ccts comprising:</p> <p>(i) 132kV double circuit and single circuit lines between Inveraray and Sloy (ISN/ICS-CSS/IK1-KS1-SN1)</p> <p>(ii) 132kV double circuit between Inveraray and Carradale (IPW-PCW/ IPE-PCE)</p> <p>(iii) 132kV double circuit between Inveraray and Taynuilt (ITE-ITW)</p>	<p>System intact in Summer condition with minimum demand.</p> <p>System conditions expected to arise in course of a year</p>	<p>None</p> <p>Typical planned outage patterns</p>	<p>GBSO operational measures in operational timescales in accordance with Section 5 of GBSQSS</p>	<p>SHETL (and SPT for their licence area) to develop the Kintyre-Hunterston Subsea link, planned completion 2014*.</p> <p>* Completion date subject to consents and regulatory approval.</p>	<p>Derogation is sought until completion of long term reinforcement solution.</p> <p>This derogation is required due to changes in network security assessment (NETS SQSS Section 2 vs.PLM-SP-1) and advancing generator connections under the interim connect and manage arrangements introduced May09</p>

Background to the network demand and generation.

In order to secure the existing South West radial network and to facilitate proposed generation connections in the area (behind Boundary B03), SHETL require a derogation against the planning criteria in clauses 2.5 to 2.13 of Section 2 of the NETS SQSS. In seeking this derogation it is expected that National Grid will continue to comply with its obligations to operate the transmission network in accordance with the operational security standards outlined in Section 5 of the NETS SQSS.

The NETS SQSS Section 2 sets out the deterministic criteria to be complied with in planning timescales. These require assessment of the intact onshore transmission system with power station maximum output for various fault contingencies. This assessment is most onerous in Summer conditions when line ratings are lowest (Summer rating), while low demand gives highest generation export. The South West outages which cause Section 2 problems are :-

- (i) Double circuit fault outage of 132kV overhead line circuits between Inveraray and Sloy (ISN/ICS-CSS), causing overload on the remaining 132kV circuit between Inveraray and the Sloy Tee.
- (ii) Single circuit fault outage on 132kV overhead line circuits between Inveraray and Sloy (ISN/ICS-CSS/IK1-KS1-SN1) during pre-planned single circuit 132kV outage on the same route, causing overload of the remaining 132kV circuit.
- (iii) Single circuit fault outage on the 132kV overhead line between Inveraray and Carradale, causing overload on the remaining 132kV circuit on the same route.
- (iv) Single circuit fault outage on the 132kV overhead line between Inveraray and Taynuilt, causing overload on the remaining 132kV circuit on the same route.
- (v) Bus section fault at Inveraray 132kV Substation causing possible overload on 132kV circuits which remain connected to Sloy, Carradale and Taynuilt, dependant on generation pattern and busbar/circuit selection at time of fault.

**SHETL South West (B03 Boundary)
Transmission System as of June 2010**

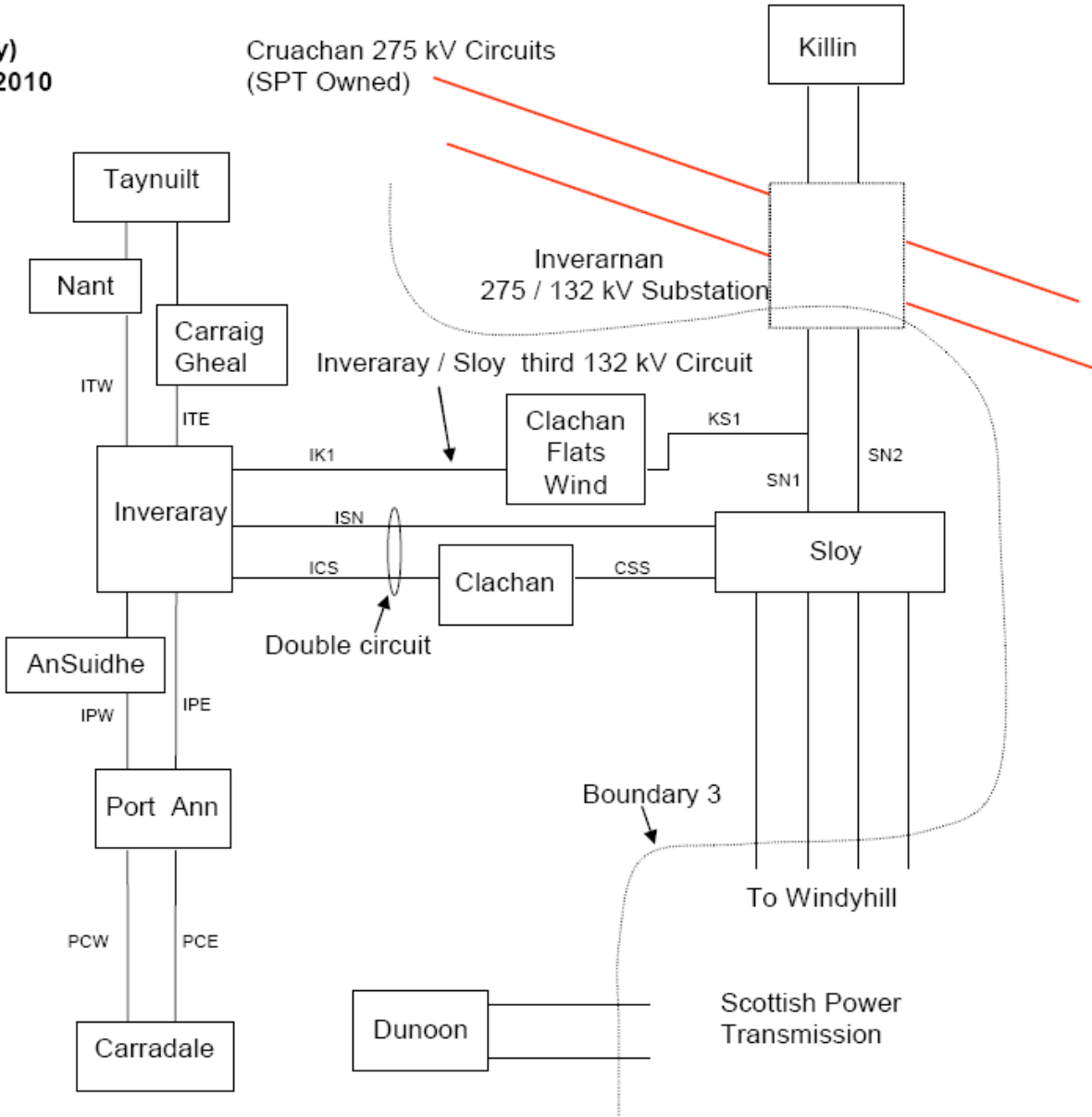

Impact assessment of the non-compliance						COMMENTS
Consumers	Security of Supply	Competition	Sustainable Development	Health and Safety and the associated risk management measures	Other Parties Affected	
<p>During the derogation there may be an increase in operational constraints and therefore operational costs, however there should not be any impact on the security of supply to consumers.</p>	<p>During the derogation period, the GBSO will continue operate the system in accordance with operational security standards (Section 5 of GBSQSS).</p> <p>This may result in increased operational constraints and therefore operational costs, however there should not be any impact on the security of supply.</p>	<p>The interim connect and manage arrangements will allow early access of generation to the network in advance any required wider transmission reinforcement works. This should facilitate competition in generation.</p>	<p>SHETL to develop the proposed Kintyre -Hunterston subsea link reinforcement as a permanent solution to address the non-compliance.</p>	<p>National Grid and SHETL will ensure that health and safety are not compromised during the derogation period.</p>	<p>There are no other parties directly affected</p>	

APPENDIX 4: Diagrams from the SYS showing boundary capability

Figure 8.B1 Boundary Transfers and Capability
Boundary 1: North West Export

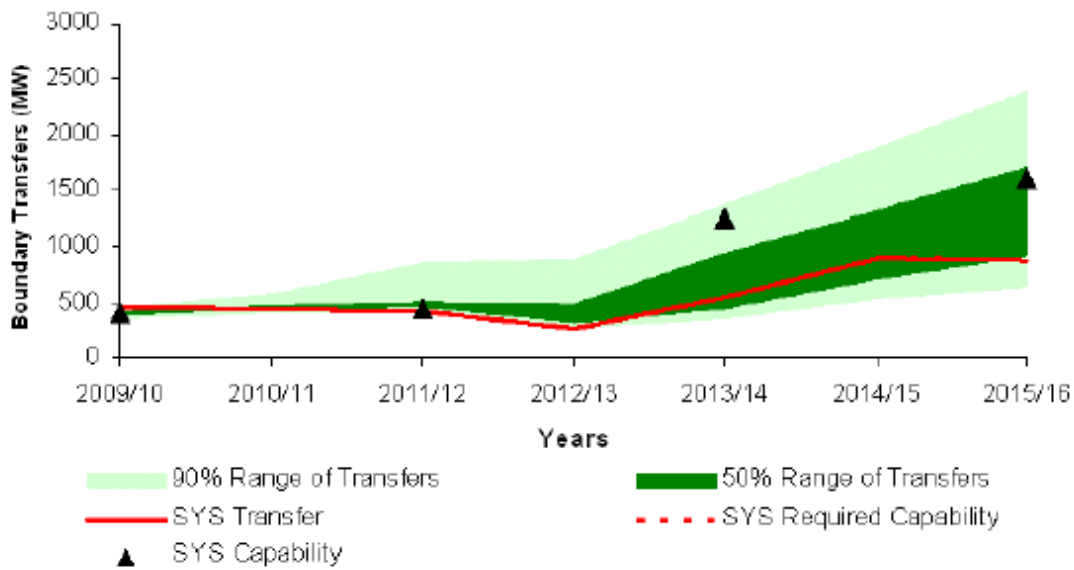

Figure 8.B3 Boundary Transfers and Capability
Boundary 3: Sloy Export

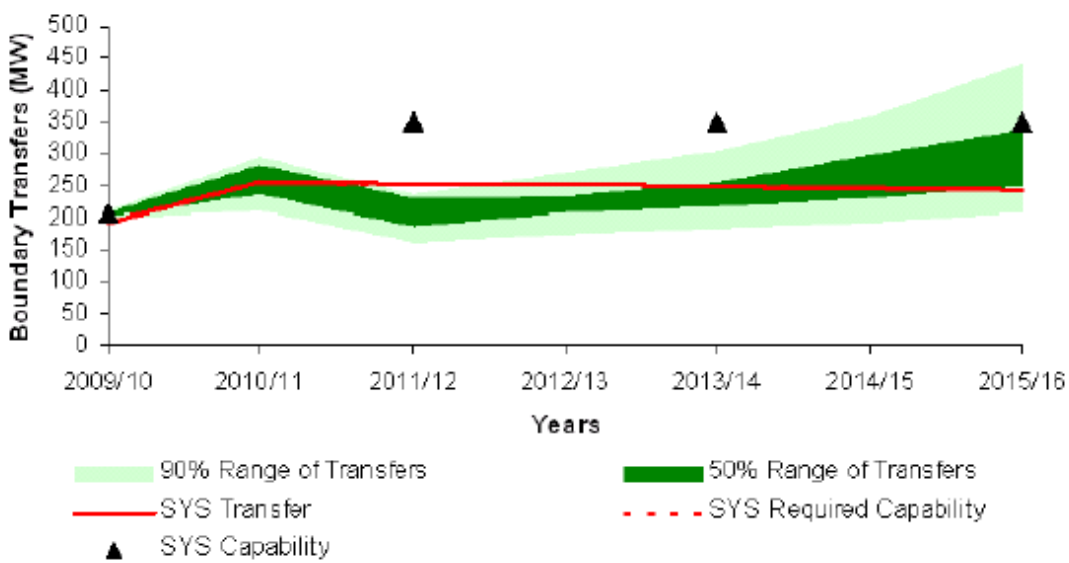
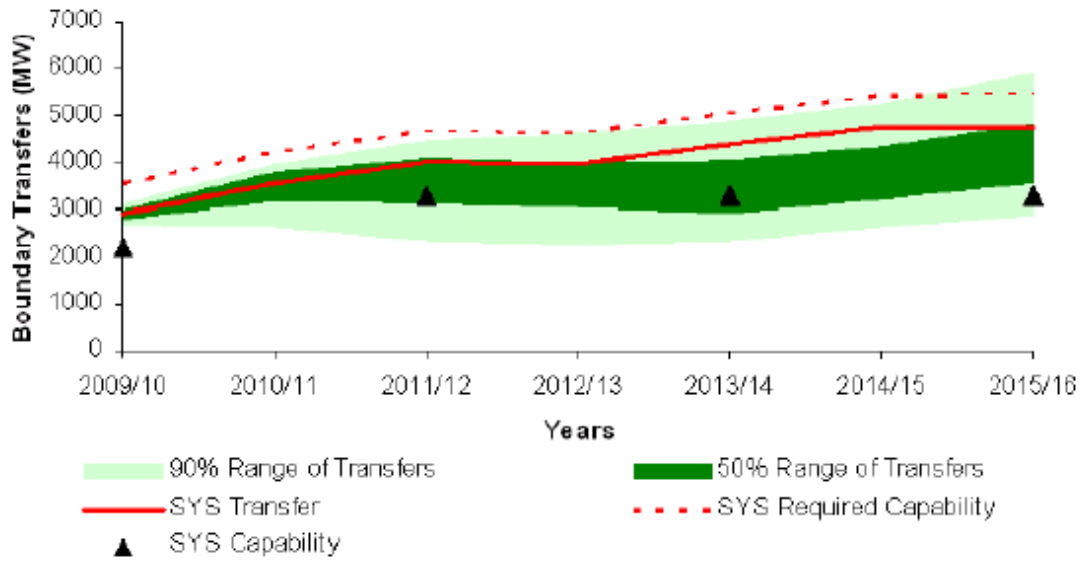

Figure 8.B6 Boundary Transfers and Capability
Boundary 6: SPT to NGET



APPENDIX 5: Embedded Generation Modelled Explicitly

Project	MW	GSP	Type	Contracted Connection Date
SHEPD				
Black Rock Hydro (ex Redburn), Evanton	4	Alness	Hydro	2008
Wester Fearn Burn Hydro	1	Alness	Hydro	2009
Monan Wind Farm, Harris	2.5	Ardmore	Wind	2009
Garvault Hydro	0.8	Cassley	Hydro	2007
Nether Dallachy Landfill Site, Spey Bay	1.15	Elgin	Waste	2007
Ardtornish additional	3	Fort William	Hydro	2009
Carnoch Hydro, Glen Tarbert (Add capacity)	1.35	Fort William	Hydro	2008
Dubh Lighe Hydro, Glenfinnan	1.3	Fort William	Hydro	2009
Glen Forslan	0.5	Fort William	Hydro	2009
North Garvan Hydro, Kinlocheil, Ft William	2	Fort William	Hydro	2008
River Finnan Hydro, Glenfinnan	0.8	Fort William	Hydro	2009
Chonais Hydro Generator, Strathcarron	3.5	Grudie Bridge	Hydro	2008
Inverlael Hydro (additional export request)	2.5	Grudie Bridge	Hydro	2008
Biomass Generator Installation, Rothes	5	Keith / Macduff	Waste	2009
Cairnmore Wind, Rhynie	2.7	Keith / Macduff	Wind	2008
Mains of Hatton Wind, Turriff	3.2	Keith / Macduff	Wind	2009
Newstead Farms	0.9	Keith / Macduff	Wind	2009
Achairn Wind Farm (additional capacity), Wick	2.5	Mybster	Wind	2008
Hill of Lieurary, Caithness	5	Mybster	Wind	2009
Nottingham Mains Wind Farm, Latheron	4.95	Mybster	Wind	2009
Olgrinmore Moss, Halkirk	4.5	Mybster	Wind	2009
Lairg 4.99MW Wind Farm	4.99	Shin	Wind	2008
Bower Quarry Wind Turbine, Caithness	0.8	Thurso	Wind	2008
Burgar Hill (RPZ)	2.3	Thurso	Wind	2009
Dounby	0.9	Thurso	Wind	2009
Flotta Wind, Orkney	2	Thurso	Wind	2009
Stromness 300 kW WTG	0.3	Thurso	Wind	2008
Kildermore	8.85	Alness	Hydro	2010
Nigg Hill	9.9	Alness	Wind	2010
Flowerdale	0.3	Grudie Bridge	Wind	2010
Gairnieston Wind	2	Keith / Macduff	Wind	2010
Gill's Bay Tidal	5	Thurso	Wave	2010
Hammars Hill RPZ	4.5	Thurso	Wind	2010
Ore Brae (Orkney)	0.9	Thurso	Wind	2010
Rousay RPZ (Orkney)	0.9	Thurso	Wind	2010
Stronsay RPZ (Orkney)	0.9	Thurso	Wind	2010
Siadar Wave, Lewis	4	Ardmore	Wave	2011
Farrmheall Wind	2.7	Cassley	Wind	2011
Carncake Wind	0	Keith / Macduff	Wind	2011
Duncansby Head Tidal	9.9	Thurso	Wave	2011
Shapinsay RPZ (Orkney)	0.9	Thurso	Wind	2011
Tuquoy Gallowhill RPZ, Westray (Orkney)	1.8	Thurso	Wind	2011
Sanday Community Wind RPZ Orkney	2.3	Thurso	Wind	2011
Barra Wind Generating Station, Isle of Barra	0.9	Ardmore	Wind	2012
Galson Wind, Barvas, Isle of Lewis	2.7	Ardmore	Wind	2012
Russel Burn Hydro	0.4	Broadford	Hydro	2012
Cairnbarrow	10	Keith / Macduff	Wind	2012

Project	MW	GSP	Type	Contracted Connection Date
Causeymire (Phase 2), Mybster	6.9	Mybster	Wind	2012
CHP Generator, Waste Recycling Plant, Stornoway	0.15	Ardmore	CHP	2013
Creed Business Park, Stornoway	0.225	Ardmore	Wind	2013
Great Bernera, Isle of Lewis	4.92	Ardmore	Wind	2013
Armada Bay	7.5	Dounreay	Wind	2014
Insch Windfarm, Insch (Additional Capacity)	1.9	Keith	Wind	2009
Dummuies	1.85		Wind	2010
Kintyre (Additional)				
Inverliever Hydro	0.5	Taynuilt	Hydro	2009
Pirnmill Hydro	0.5	Carradale	Hydro	2011
Armaddy	0.13	Taynuilt	Hydro	2011
Braevallich Hydro Scheme	0.13	Taynuilt	Hydro	2012
Ardnacross, Isle of Mull	0.15	Taynuilt	Hydro	2011
Mull Cheese Hydro, Tobermory (Phase 2)	0.19	Taynuilt	Hydro	2010
Clachan Kintyre Hydro	0.25	Carradale	Hydro	2011
Monyquil Hydro	0.35	Carradale	Hydro	2012
Lochranza Hydro Generating Station	0.4	Carradale	Hydro	2012
Sannox Hydro Generating Station	0.45	Carradale	Hydro	2012
Drumdrishaig / Ballure Hydro, Kintyre	0.5	Port Ann	Hydro	2011
Jura, Glen Astaile	0.65	Port Ann	Wind	2011
Blarghour Farm	0.875	Taynuilt	Hydro	2012
Merk Hydro Scheme	0.99	Clachan	Hydro	2011
Muasdale Wind	0.9	Port Ann	Wind	2011
Gigha Heritage Trust Wind T4	0.225	Carradale	Wind	2011
Kames River	0.9	Taynuilt	Hydro	2012
Appin Hydro Generation Scheme	1	Taynuilt	Hydro	2013
Kintarbet, Tarbert, Loch Fyne	0.9	Port Ann	Hydro	2013
Achnabreck Biopower	5.352	Port Ann	Biomass	2011
Arran Biopower Plant	5.352	Carradale	Biomass	2013
Islay Tidal Farm, Portnahaven, Islay	7.2	Port Ann	Tidal	2013
Clachan Farm, Kilninver	9.9	Taynuilt	Wind	2013
Allt Dearg, Inverneil	9.95	Port Ann	Wind	2013
Ederline Hydro	2	Taynuilt	Hydro	2013
Campbeltown Biopower	5.352	Carradale	Biomass	2013
Allt Fionn, Ben Glas & Falloch Hydro Schemes	6.1	Taynuilt	Hydro	2010
SPD				
Carcant	6.0	Edinburgh	Wind	2010
Little Raith	27.0	Gleniston	Wind	2011
Irvine Biomass	5.5	Riverside Irvine	Biomass	2010
Pate's Hill	14.0	Livingston	Wind	2009
		Symington		
Glenkerie (Middle Hill)	18.4	Borders	Wind	2011
Longannet Biomass	25.2	Kincardine	Biomass	2012
Craigengelt	20.0	Stirling	Wind	2009
Burnfoot	26.0	Ochil Hills	Wind	2011
Drumshangie CHP	27.0	Airdrie	Biomass	2012