

Issue	Revision
1	0

The Statement of the Connection Charging Methodology

Effective from 1 April 2005

Draft for Industry Comment

About this Document

This document describes the methodology that National Grid Company plc (National Grid), employs to levy charges for connection to the transmission system in Great Britain (GB) on behalf of National Grid Company plc, Scottish Power Transmission Ltd and Scottish Hydro-Electric Transmission Ltd. This document is one of a suite of three documents that describe the charges levied by National Grid and the methodologies behind them. The other documents are:

- **The Statement of the Use of System Charging Methodology**
- **The Statement of Use of System Charges**

| These are available on our Charging website at:

http://www.nationalgridinfo.co.uk/betta/gb_charging.html

This Statement of the Connection Charging Methodology Issue 1, Revision 0 is effective from 1 April 2005.

This document has been published by National Grid in accordance with Condition C6 of National Grid's Transmission Licence and is approved by the Gas and Electricity Markets Authority (the Authority).

If you require further details about any of the information contained within this document or have comments on how this document might be improved please contact our **Charging Team**, preferably by email at:

charging.enquiries@ngtuk.com

or at:

NGT House
Warwick Technology Park
Gallows Hill
Warwick
CV34 6DA

Telephone 01926 654633

Contents

GENERAL INTRODUCTION	5
National Grid's Licence Obligations	5
Relevant Objectives	6
The Contractual Framework	8
CHAPTER 1: PRINCIPLES	9
Costs and their Allocation	9
Connection/Use of System Boundary	9
CHAPTER 2: THE CALCULATION OF THE BASIC ANNUAL CONNECTION CHARGE FOR AN ASSET	10
Pre and Post Vesting Connections	10
Calculation of the Gross Asset Value (GAV)	10
Calculation of Net Asset Value	11
Capital Components of the Connection charge for Post Vesting Connection Assets	11
Capital Components of the Connection charge for Pre Vesting Connection Assets	12
Non-Capital Components - Charging for Maintenance and Transmission Running Costs	13
Part A: Site Specific Maintenance Charges	13
Part B: Transmission Running Costs	13
The Basic Annual Connection Charge Formula	14
Adjustment for Capital Contributions	15
Modification of Connection Assets	15
CHAPTER 3: OTHER CHARGES	16
One-off Works	16
Miscellaneous Charges	17
Rental sites	17
Final Metering Scheme (FMS)/Energy Metering Systems	17
CHAPTER 4: CONNECTION AGREEMENTS	18
Indicative Agreement	18
Outturning the Indicative Agreement	18
Firm Price Agreement	18
Monthly Connection Charges	19
CHAPTER 5: TERMINATION CHARGES	20
Charges Liable	20
Repayment on Re-Use of Assets	21
Valuation of Assets that are re-used as connection assets or existing infrastructure assets re-allocated to connection	21
CHAPTER 6: CONTESTABILITY	22
Contestability in Construction	22
Contestability in the Maintenance Service	22
CHAPTER 7: ASSET REPLACEMENT	23
Asset Replacement that includes a change of Voltage	23
CHAPTER 8: DATA REQUIREMENTS	25
CHAPTER 9: APPLICATIONS	26
APPENDIX 1: ILLUSTRATIVE CONNECTION CHARGES	27
2004/2005 First Year Connection Charges based on the RPI Method (6% rate of return)	27
Connection Examples	29
APPENDIX 2: EXAMPLES OF CONNECTION CHARGE CALCULATIONS	33
Example 1	33
Example 2	34
Example 3	34
Example 4	35
CHAPTER 10: NOMINALLY OVER EQUIPPED CONNECTION SITES	36
Historical	36

Early Construction	36
Connection site Specific Technical or Economic Conditions	36
GLOSSARY	37
INDEX TO THE STATEMENT OF THE CONNECTION CHARGING METHODOLOGY (ISSUE 1) REVISIONS	42

General Introduction

National Grid's Licence Obligations

1 As the holder of Transmission Licences in Great Britain, the GB transmission licensees are required by the Electricity Act 1989, as amended by the Utilities Act 2000 and the Energy Act 2004, to develop and maintain an efficient, co-ordinated and economical system of electricity transmission and to facilitate competition in the generation and supply of electricity. The transmission licensees are also required by Schedule 9 of the Electricity Act to have regard for the effects of its activities on the environment.

2 National Grid's Transmission Licence Conditions were changed by the Secretary of State through the Energy Act 2004 as part of the implementation of the British Electricity Trading and Transmission Arrangements (BETTA). Consequently National Grid is responsible for the determination and implementation of a GB connection charging methodology that has effect from 1 April 2005. Following the changes, Licence Condition C6 of the National Grid Transmission Licence states that:

The Licensee (National Grid) shall as soon as practicable after the date this Condition comes into effect prepare a statement approved by the Authority of the connection charging methodology in relation to charges, including charges:

- a. *for the carrying out of works and the provision and installation of electrical lines or electrical plant or meters for the purposes of connection (at entry or exit points) to the GB transmission system;*
- b. *in respect of extension or reinforcement of the GB transmission system rendered (at the discretion of a transmission licensee where the extension or reinforcement is of that licensee's transmission system) necessary or appropriate by virtue of the licensee providing connection to or use of system to any person seeking connection;*
- c. *in circumstances where the electrical lines or electrical plant to be installed are (at the discretion of a transmission licensee where the electrical lines or electrical plant which are to be installed will form part of that licensee's transmission system) of greater size than that required for use of system by the person seeking connection;*
- d. *for maintenance and repair (including any capitalised charge) required of electrical lines or electrical plant or meters provided or installed for making a connection to the GB transmission system; and*
- e. *for disconnection from the GB transmission system and the removal of electrical plant, electrical lines and meters following disconnection.*

3 National Grid is also required by the Transmission Licence:

- *to offer terms for connection to and use of the GB system or for the modification of an existing connection within three months of application;*
- *to offer terms for use of the GB system only within 28 days of application;*

- *not to discriminate between any persons or class or classes of persons in providing use of the GB system or in carrying out works for connection.*
- 4 Licence Condition C11 also requires National Grid no later than 31 May 2005 for the financial year ending 31 March 2005 and by 31 March in each financial year thereafter, to prepare a statement in a form approved by the Authority showing in respect of each of the seven succeeding financial years circuit capacity, forecast power flows and loading on each part of the GB transmission system and fault levels for each transmission node, together with:
- a. *such further information as shall be reasonably necessary to enable any person seeking use of system to identify and evaluate the opportunities available when connecting to and making use of such system;*
 - b. *a commentary prepared by the licensee indicating those parts of the GB transmission system most suited to new connections and transport of further quantities of electricity; and*
 - c. *such other matters as shall be specified in directions issued by the Authority from time to time for the purposes of this condition.*

Relevant Objectives

- 5 As part of Licence Condition C6 National Grid has to ensure that the Connection Charging Methodology meets the relevant licence objectives as specified in C6(5) and C6(11) in relation to connection charges. The relevant objectives are set out as follows:
- a. *That compliance with the Connection Charging Methodology facilitates effective competition in the generation and supply of electricity and (so far as consistent therewith) facilitates competition in the sale, distribution and purchase of electricity;*
 - b. *That compliance with the Connection Charging Methodology results in charges which reflect, as far as reasonably practicable, the costs (excluding any payments between transmission licensees which are made under and in accordance with the STC) incurred by licensees in their transmission businesses; and*
 - c. *That so far as is consistent with the sub-paragraphs (a) and (b), the Connection Charging Methodology, as far as is reasonably practicable, properly takes account of the developments in the transmission licensees' transmission Businesses;*
 - d. *In so far as consistent with sub paragraphs (a), (b) and (c) of facilitating competition in the carrying out of works for connection to the GB transmission system.*

In interpretation of the above objectives, Standard Condition C1 of National Grid's Transmission License shall prevail in its definition of connection charges and use of system charges in respect of the GB transmission system.

- 6 The Licence states that National Grid must keep the Connection Charging Methodology under review at all times for the purpose of ensuring that the methodologies meet the relevant objectives outlined above.

- 7 National Grid may make modifications to the Methodology as may be required for the purpose of better meeting the relevant objectives above.
- 8 Before making any modifications, unless it has been agreed otherwise with the Authority, National Grid will consult with CUSC parties for a period of at least 28 days on the proposed change to the Connection Charging Methodologies where written representations can be made.
- 9 A report will then be issued to the Authority by National Grid setting out the terms of the modification, representations made, any change to the terms of the modification, how the modification better meets the relevant objectives and a timetable and date for implementation of the modification.
- 10 Unless the Authority has, within 28 days of the report being furnished to it, given a direction that the modification may not be made, National Grid will make the modification to the Connection Charging Methodology.
- 11 Once a modification is made National Grid will issue a revised statement showing the changed Connection Charging Methodology. The revised Connection Charging Methodology statement will supersede all previous statements from the date of its issue.

The Contractual Framework

- 12 The Connection and Use of System Code (CUSC) is a multi-party document creating contractual obligations among and between all users of the transmission system, parties connected to the GB transmission system and National Grid. Persons wishing to use and/or connect to the GB transmission system will be required to accede to the CUSC by signing the Framework Agreement and to enter into a Bilateral Agreement with National Grid.
- 13 National Grid continues to request that Small Power Stations make a formal application for use of the system. National Grid can then assess the potential impact on the transmission system and consider what form of agreement, if any, may be required.
- 14 The CUSC and individual User's Bilateral Agreements set out the terms and conditions applicable for use of and/or connection to the transmission system. In particular, they set out the User's obligations to:
- pay all use of system and connection charges;
 - comply with the provisions of the Grid Code;
 - sign on to the Balancing and Settlement Code (BSC);
 - enter into an appropriate Mandatory Services Agreement.
- 15 Additionally, each Bilateral Agreement details the information on which the User's connection charges are based:
- Appendix A of each Bilateral Agreement lists the connection assets by description and age to the User;
 - Appendix B identifies the connection charges;
- 16 If a User fails to fulfil their obligations, their entitlement to use and/or be connected to the GB transmission system will cease. The User will be liable for all charges that may arise up to the end of the current Financial Year and, for connection, the appropriate termination sum.
- 17 When a User applies for a new connection to the system or to modify an existing connection they may be required to enter into a Construction Agreement. Within the Construction Agreement there will be provisions for site specific elements such as Consents and Final Sums.

Chapter 1: Principles

Costs and their Allocation

- 1.1 Connection charges enable National Grid to recover, with a reasonable rate of return, the costs involved in providing the assets that afford connection to the GB transmission system.
- 1.2 Connection charges relate to the costs of assets installed solely for and only capable of use by an individual User.
- 1.3 Connection charges are designed not to discriminate between Users or classes of User. The methodology is applied to both connections that were in existence at Vesting (30 March 1990) and those that have been provided since.

Connection/Use of System Boundary

- 1.4 The first step in setting charges is to define the boundary between connection assets and transmission system infrastructure assets.
- 1.5 In general, connection assets are defined as those assets solely required to connect an individual User to the GB transmission system, which are not and would not normally be used by any other connected party (i.e. "single user assets"). For the purposes of this Statement, all connection assets at a given location shall together form a connection site.
- 1.6 Connection assets are defined as all those single user assets which:
 - a) for Double Busbar type connections, are those single user assets connecting the User's assets and the first transmission licensee owned substation, up to and including the Double Busbar Bay;
 - b) for teed or mesh connections, are those single user assets from the User's assets up to, but not including, the HV disconnector.
 - c) for cable and overhead lines at a transmission voltage, are those single user connection circuits connected at a transmission voltage equal to or less than 2km in length that are not potentially shareable.
- 1.7 Shared assets at a banked connection arrangement will not normally be classed as connection assets except where both legs of the banking are single user assets under the same Bilateral Connection Agreement.
- 1.8 Where customer choice influences the application of standard rules to the connection boundary, affected assets will be classed as connection assets. For example, in England & Wales National Grid does not normally own busbars below 275kV, where National Grid and the customer agree that National Grid will own the busbars at a low voltage substation, the assets at that substation will be classed as connection assets and will not automatically be transferred into infrastructure.
- 1.9 The design of some connection sites may not be compatible with the basic boundary definitions in 1.6 above. In these instances, a connection boundary consistent with the principles described above will be applied.

Chapter 2: The Calculation of the Basic Annual Connection Charge for an Asset

Pre and Post Vesting Connections

- 2.1 Post Vesting connection assets are those connection assets that have been commissioned since 30 March 1990. Pre Vesting connection assets are those that were commissioned on or before the 30 March 1990.
- 2.2 The basic connection charge has two components. A non-capital component, for which both pre and post vesting assets are treated in the same way and a capital component for which there are slightly different options available for pre and post vesting assets. These are detailed below.

Calculation of the Gross Asset Value (GAV)

- 2.3 The GAV represents the initial total cost of an asset to the transmission licensee. For a new asset it will be the costs incurred by the transmission licensee in the provision of that asset. Typically, the GAV is made up of the following components:

Construction Costs - Costs of bought in services
Engineering - Allocated equipment and direct engineering cost
Interest During Construction – Financing cost
Liquidated Damages Premiums - Premium required to cover Liquidated Damages if applicable.

Some of these elements may be optional at the User's request and are a matter of discussion and agreement at the time the connection agreement is entered into.

- 2.4 The GAV of an asset is re-valued each year normally using one of two methods. For ease of calculation, April is used as the base month.
- In the Modern Equivalent Asset (MEA) revaluation method, the GAV is indexed each year with reference to the prevailing price level for an asset that performs the same function as the original asset;
 - In the RPI revaluation method, the original cost of an asset is indexed each year by the Retail Price Index (RPI) formula set out in paragraph 2.6. For Pre Vesting connection assets commissioned on or before 30 March 1990, the original cost is the 1996/97 charging GAV (MEA re-valued from vesting). The original costs of Post Vesting assets are calculated based on historical cost information provided by the transmission licensee's.
- 2.5 In the MEA revaluation method, the MEA value is based on a typical asset. An MEA ratio is calculated to account for specific site conditions, as follows:
- The outturn GAV (as calculated in paragraph 2.3 above) is re-indexed by RPI to the April of the Financial Year the Charging Date falls within;
 - This April figure is compared with the MEA value of the asset in the Financial Year the Charging Date falls within and a ratio calculated;

- If the asset was commissioned at a Connection Site where, due to specific conditions, the asset cost more than the standard MEA value, the ratio would be greater than 1. For example, if an asset cost 10% more to construct and commission than the typical asset the MEA ratio would be 1.1. If, however, the asset was found only to cost 90% of the typical MEA value the ratio would be 0.9;
- The MEA ratio is then used in all future revaluations of the asset. The April GAV of the asset in any year is thus the current MEA value of the asset multiplied by the ratio calculated for the Financial Year the Charging Date falls within.

2.6 The RPI revaluation method is as follows:

- The outturn GAV (as calculated in paragraph 2.3 above) is re-indexed by RPI to the April of the Financial Year the Charging Date falls within. This April GAV is thus known as the Base Amount;
- The Base Amount GAV is then indexed to the following April by using the RPI formula used in National Grid's Price Control. April GAVs for subsequent years are found using the same process of indexing by RPI.

$$\text{i.e. } GAV_n = GAV_{n-1} * RPI_n$$

- The RPI calculation for year n is as follows:

$$RPI_n = \frac{[\text{May to October average RPI Index}]_{n-1}}{[\text{May to October average RPI Index}]_{n-2}}$$

Calculation of Net Asset Value

2.7 The Net Asset Value (NAV) of each asset for year n, used for charge calculation, is the average (mid year) depreciated GAV of the asset. The following formula calculates the NAV of an asset, where A_n is the age of the asset (number of completed charging years old) in year n:

$$NAV_n = GAV_n * \frac{\text{Depreciation Period} - (A_n + 0.5)}{\text{Depreciation Period}}$$

2.8 In constant price terms an asset with an initial GAV of £1m and a depreciation period of 40 years will normally have a NAV in the year of its commissioning of £0.9875m (i.e. a reduction of 1.25%) and in its second year of £0.9625m (i.e. a further reduction of 2.5% or one fortieth of the initial GAV). This process will continue with an annual reduction of 2.5% for each year of the asset's life.

Capital Components of the Connection charge for Post Vesting Connection Assets

2.9 The standard terms for a connection offer will be:

- 40 year life (with straight line depreciation);
- RPI indexation

2.10 In addition a number of options exist:

- a capital contribution based on the allocated GAV at the time of commissioning will reduce capital. Typically a capital contribution will include costs to cover the elements outlined below and charges are calculated as set out in the equations below;
- Construction costs
- Engineering costs (Engineering Charge x job hours)
- Interest During Construction (IDC)
- Return element (6%)
- Liquidated Damages Premium (LD) (if applicable)

General Formula:

Capital Contribution Charge = (Construction Costs + Engineering Charges) x (1+Return %) + IDC + LD Premium

- MEA revaluation which is combined with a 7.5% rate of return, as against 6% on the standard RPI basis;
- annual charges based on depreciation periods other than 40 years;
- annuity based charging;
- indexation of GAVs based on principles other than MEA revaluation and RPI indexation. No alternative forms of indexation have been employed to date.

2.11 For new connection assets, should a User wish to agree to one or more of the options detailed above, instead of the standard connection terms, the return elements charged by the transmission licensee may also vary to reflect the re-balancing of risk between the transmission licensee and the User. For example, if Users choose a different indexation method, an appropriate rate of return for such indexation method will be derived.

Capital Components of the Connection charge for Pre Vesting Connection Assets

2.12 The basis of connection charges for GB assets commissioned on or before 30 March 1990 is broadly the same as the standard terms for connections made since 30 March 1990. Specifically charges for pre vesting connection assets are based on the following principles:

- The GAV is the 1996/97 charging GAV (MEA re-valued from vesting) subsequently indexed by the same measure of RPI as used in National Grid's Price Control;
- 40 year life (with straight line depreciation);
- 6% rate of return

2.13 Pre-vesting 1996 MEA GAVs for Users' connection sites are available from National Grid on request from the **Charging Team**.

Non-Capital Components - Charging for Maintenance and Transmission Running Costs

- 2.14 The non-capital component of the connection charge is divided into two parts, as set out below. Both of these non-capital elements will normally be identified in the charging appendices of relevant Bilateral Agreements.

Part A: Site Specific Maintenance Charges

- 2.15 This is a maintenance only component that recovers a proportion of the costs and overheads associated with the maintenance activities conducted on a site specific basis for connection assets of the transmission licensees.
- 2.16 Site specific maintenance charges will be calculated each year based on the forecast total site specific maintenance for GB divided by the total GAV of the transmission licensees GB connection assets, to arrive at a percentage of total GAV. For 2005/6 this will be 0.5%, subject to review. For the avoidance of doubt, there will be no reconciliation of the site specific maintenance charge.

Part B: Transmission Running Costs

- 2.17 The Transmission Running Cost (TRC) factor is calculated each year to reflect the appropriate amount of other Transmission Running Costs (rates, operation, indirect overheads) incurred by the transmission licensees that should be attributed to connection assets.
- 2.18 The TRC factor is calculated by taking a proportion of the forecast Transmission Running Costs for the transmission licensees (based on operational expenditure figures from the latest price control) that corresponds with the proportion of the transmission licensees' total connection assets as a function of their total business GAV. This cost factor is therefore expressed as a percentage of an asset's GAV and will be fixed for the entirety of the price control period.
- 2.19 To illustrate the calculation, the following example uses the average cost of the current price control operating costs and an estimation of the connection assets of each transmission licensee as a percentage of total GAV to arrive at a GB TRC of 1.7%:

Example:

Connection assets as a percentage of total system GAV for each TO:

Scottish Power Transmission Ltd	10%
Scottish Hydro Transmission Ltd	11%
National Grid	11.5%

Published current price control average annual operating expenditure (£m):

Scottish Power Transmission Ltd	35
Scottish Hydro Transmission Ltd	20
National Grid	298

Total GB Connection GAV = £1.8bn

$$\text{GB TRC Factor} = (10\% \times \text{£}35\text{m} + 11\% \times \text{£}20\text{m} + 11.5\% \times \text{£}298\text{m}) / \text{£}1.8\text{bn}$$

$$\text{GB TRC Factor} = 2.2\%$$

$$\text{Net GB TRC Factor} = \text{Gross GB TRC Factor} - \text{Site Specific Maintenance Factor}$$

$$\text{Net GB TRC Factor} = 2.2\% - 0.5\% = 1.7\%$$

The Basic Annual Connection Charge Formula

2.20 The charge for each connection asset in year n can be derived from the general formula below. This is illustrated more fully by the examples in **Appendix 2: Examples of Connection Charge Calculations.**

$$\text{Annual Connection Charge}_n = D_n (\text{GAV}_n) + R_n (\text{NAV}_n) + \text{SSF}_n (\text{RPIGAV}_n) + \text{TC}_n (\text{GAV}_n)$$

Where:

For n	=	year to which charge relates within the Depreciation Period
n	=	year to which charge relates
GAV _n	=	GAV for year n re-valued by relevant indexation method
RPIGAV _n	=	GAV for year n re-valued by RPI indexation
NAV _n	=	NAV for year n based on re-valued GAV _n
D _n	=	Depreciation rate as percentage (equal to 1/Depreciation Period) (typically 1/40 = 2.5% of GAV)
R _n	=	real rate of return for chosen indexation method (6% for RPI indexation, 7.5% for MEA Indexation)
SSF _n	=	Indicative Site Specific Factor for year n as a % (equal to the Site Specific Cost/Total Site GAV), reconciled in year n+1
TC _n	=	Transmission Running cost component for year n (other Transmission Owner Activity costs).
For n	=	year to which charge relates beyond the Depreciation Period
n	=	year to which charge relates
GAV _n	=	GAV for year n re-valued by relevant indexation method
RPIGAV _n	=	GAV for year n re-valued by RPI indexation
NAV _n	=	0
D _n	=	0
R _n	=	real rate of return for chosen indexation method (6% for RPI indexation, 7.5% for MEA Indexation)
SSF _n	=	Indicative Site Specific Factor for year n as a % (equal to the Site Specific Cost/Total Site GAV), reconciled in year n+1
TC _n	=	Transmission Running cost component for year n (other Transmission Owner Activity costs).

2.21 Note that, for the purposes of deriving asset specific charges for site specific maintenance, the RPI re-valued GAV is used. This is to ensure that the exact site charges are recovered from the assets at the site. The site costs are apportioned to the assets on the basis of the ratio of the asset GAV to total Site GAV.

Adjustment for Capital Contributions

- 2.22 If a User chooses to make a 100% capital contribution to National Grid towards their allocation of a connection asset then no capital charges will be payable and hence the connection charges for that asset would be calculated as follows:

$$\text{Annual Connection Charge}_n = \text{SSF}_n (\text{RPIGAV}_n) + \text{TC}_n (\text{GAV}_n)$$

- 2.23 If a User chooses to make a partial capital contribution to National Grid towards their allocation of a connection asset, for example PCCF = 50%, then the connection charges for that asset would be calculated as follows:

$$\text{Annual Connection Charge}_n = D_n (\text{GAV}_n * \text{PCCF}) + R_n (\text{NAV}_n * \text{PCCF}) + \text{SSF}_n (\text{RPIGAV}_n) + \text{TC}_n (\text{GAV}_n)$$

PCCF = Partial Capital Contribution Factor

Modification of Connection Assets

- 2.24 Where a modification to an existing connection occurs at the User's request or due to developments to the transmission system, their annual connection charges will reflect any additional connection assets that are necessary to meet the User's requirements. Charges will continue to be levied for existing assets that remain in service. Termination charges as described in **Chapter 5** below will be charged for any existing connection assets made redundant as a result of the modification.

Chapter 3: Other Charges

3.1 In addition to the basic annual connection charges set out above, the User may pay the transmission licensee for certain other costs related to their connection. These will be set out in the Bilateral and Construction Agreements where appropriate and are described below.

One-off Works

3.2 To provide or modify a connection, the transmission licensee may be required to carry out works on the transmission system, that although directly attributable to the connection, may not give rise to additional connection assets. These works are defined as “one-offs”. Liability for one-off charges is established with reference to the principles laid out below:

- Where a cost cannot be capitalised into either a connection or infrastructure asset, typically a revenue cost
- Where a non-standard incremental cost is incurred as a result of a User's request, irrespective of whether the cost can be capitalised
- Termination Charges associated with the write-off of connection assets at the connection site.

3.3 The one-off charge is a charge equal to the cost of the works involved, together with a reasonable return, as shown in 3.4 below.

3.4 For information, the general formula for the calculation of the one-off charge for works is outlined below.

$$\text{One-off Charge} = (\text{Construction Costs} + \text{Engineering Charges}) \times (1 + \text{Return \%}) + \text{IDC} + \text{LD Premium}$$

Where:

- Engineering Charges = “Engineering Charge” x job hours
- Return % = 6%
- IDC = Interest During Construction
- LD Premium = National Grid Liquidated Damages Premium (if applicable)

3.5 The calculation of the one-off charge for write-off of assets is outlined below:

$$\text{Write-off Charge} = 100\% \text{ of remaining NAV of redundant assets}$$

3.6 One-offs are normally paid on an agreed date, which is usually upon completion of the works. However, arrangements may be agreed between the transmission licensee and the User to pay the charge over a longer period. If a one-off is paid over a longer period it is termed a Transmission Charge. It is usually a depreciating finance charge or annuity based charge with a rate of return element and may include agreement on a schedule of termination payments if the agreement is terminated before the end of the annuity period. The charge is usually inflated annually by the same RPI figure that is used to inflate GAVs, though Users can request alternative indexation methods.

Miscellaneous Charges

- 3.7 Other contract specific charges may be payable by the User, these will be set out in the Bilateral and Construction Agreements where appropriate.

Rental sites

- 3.8 Where National Grid owns a site that is embedded within a distribution network, the connection charge to the User is based on the capital costs and overheads but does not include maintenance charges.

Final Metering Scheme (FMS)/Energy Metering Systems

- 3.9 Charges for FMS metering are paid by the registrant of the FMS metering at the connection site. It is charged on a similar basis as other Connection Assets. The electronic components of the FMS metering have a replacement and depreciation period in line with those advised by the transmission licensees, whilst the non-electronic components normally retain a 40 year replacement and depreciation period (or a User specified depreciation period as appropriate).

Chapter 4: Connection Agreements

Indicative Agreement

- 4.1 The standard connection agreement offered by National Grid is an indicative price agreement. From the Charging Date as set out in the User's Bilateral Connection Agreement, the User's initial connection charge is based on a fair and reasonable estimate of the expected costs of the connection.

Outturning the Indicative Agreement

- 4.2 Once the works required to provide a new or modified connection are completed and the costs finalised, the connection scheme is "outturned". National Grid reconciles the monies paid by the User on the indicative charge basis against the charges that would have been payable based on the actual costs incurred in delivering the project together with any relevant interest. This process involves agreeing a new charging GAV (The Base Amount) with the User in line with the elements stated in paragraph 2.3 and then calculating connection charges with this GAV.
- 4.3 In addition, for Users that have chosen MEA revaluation their MEA ratios are agreed at outturn and this ratio is used for MEA revaluation in subsequent years.
- 4.4 In the case of connection asset replacement where there is no initiating User, the outturn is agreed with the User at the site.

Firm Price Agreement

- 4.5 In addition to the options stated in paragraph 2.10 above, firm price agreements are also available. Typically with this option the charges to be incurred, and any indexation, are agreed between National Grid and the User and connection charges are not recalculated once outturn costs are known. A typical example of a firm price agreement is:
- Capital Contribution
 - Firm Price GAV
 - Running Costs (based on a firm price GAV)
 - Fixed Schedule of Termination Amounts
- 4.6 When a User selects a firm price agreement some or all of the above elements can be made firm. Any elements of the agreement that have not been made firm will be charged on an indicative basis in accordance with this statement.
- 4.7 Final Sums and Consents costs are never made firm in a Firm Price Agreement. Details of both are set out in the Construction Agreement.

Monthly Connection Charges

- 4.8 The connection charge is an annual charge payable monthly.
- 4.9 If the initial Charging Date does not fall within the current Financial Year being charged for and there are no revisions to charges during the year, the monthly connection charge will equal the annual connection charge divided by twelve.
- 4.10 For the Financial Year in which the Charging Date occurs (as set out in the User's Bilateral Agreement) or for any Financial Year in which a revision to charges has occurred during the Financial Year, for each complete calendar month from the Charging Date (or effective date of any charge revision) to the end of the Financial Year in which the Charging Date (or charge revision) occurs, the monthly connection charge shall be equal to the annual connection charge divided by twelve.
- 4.11 For each part of a calendar month, the charge will be calculated as one twelfth of the annual connection charge prorated by the ratio of the number of days from and including the Charging Date to the end of the month that the Charging Date falls in and the number of days in that month.
- 4.12 For example, say the annual connection charge for Financial Year 1999/2000 is £1.2m and the Charging Date falls on the 15th November 1999, the monthly charges for the Financial Year 1999/2000 would be as follows:
- November = $£1,200,000/12 * (16/30)$ = £53,333.33
 - Dec 99, Jan 00, Feb 00, Mar 00 = $£1,200,000/12$ = £100,000.00
- 4.13 The above treatment does not apply to elements such as Miscellaneous Charges (as defined in 3.7) and Transmission Charges (annuitised one-offs, as defined in 3.6). If the Charging Date falls within a Financial Year, then the full annual charge will remain payable and will be spread evenly over the remaining months. This is because these payments are an annuitisation of charges that would normally be paid up-front as one-off payments.

Chapter 5: Termination Charges

Charges Liable

5.1 Where a User wholly or partially disconnects from the transmission system they will pay a termination charge. The termination charge will be calculated as follows:

- Where the connection assets are made redundant as a result of the termination or modification of a Bilateral Connection Agreement, the User will be liable to pay an amount equal to the NAV of such assets as at the end of the financial year in which termination or modification occurs, plus:
- The reasonable costs of removing such assets. These costs being inclusive of the costs of making good the condition of the connection site
- If a connection asset is terminated before the end of a Financial Year, the connection charge for the full year remains payable. Any remaining Use of System Charges (TNUoS and BSUoS) also remain payable
- For assets where it has been determined to replace upon the expiry of the relevant Replacement Period in accordance with the provisions set out in the CUSC and in respect of which a notice to Disconnect or terminate has been served in respect of the Connection Site at which the assets were located; and due to the timing of the replacement of such assets, no Connection Charges will have become payable in respect of such assets by the User by the date of termination; the termination charges will include the reasonable costs incurred by the transmission licensee in connection with the installation of such assets
- Previous capital contributions paid to National Grid will be taken into account

5.2 The Calculation of Termination amounts for financial year n is as follows:

$$\text{Termination Charge}_n = \text{UoS}_n + C_n + \text{NAV}_{an} + R - \text{CC}$$

Where:

UoS_n = Outstanding Use of System Charge for year (TNUoS and BSUoS)

C_n = Outstanding Connection Charge for year

NAV_{an} = NAV of Type A assets as at 31 March of financial year n

R = Reasonable costs of removal of redundant assets and making good

CC = An allowance for previously paid capital contributions

5.3 Examples of reasonable costs of removal for terminated assets and making good the condition of the site include the following:

- If a circuit breaker is terminated as a result of a User leaving a site, this may require modifications to the protection systems.
- If an asset were terminated and its associated civils had been removed to 1m below ground then the levels would have to be made up. This is a common condition of planning consent.

Repayment on Re-Use of Assets

- 5.4 If any assets in respect of which a termination charge was made to National Grid are re-used at the same site or elsewhere on the system, including use as infrastructure assets, National Grid will make a payment to the original terminating User to reflect the fact that the assets are being re-used.
- 5.5 The arrangements for such repayments for re-use of Assets are that National Grid will pay the User a sum equal to the lower of:
- i.) the Termination Amount paid in respect of such Assets; or
 - ii.) the NAV attributed to such Assets for charging purposes upon their re-use
- less any reasonable costs incurred in respect of the storage of those assets.
- 5.6 The definition of re-use is set out in the CUSC. Where National Grid decides to dispose of a terminated asset where it is capable of re-use, National Grid shall pay the User an appropriate proportion of the sale proceeds received.

Valuation of Assets that are re-used as connection assets or existing infrastructure assets re-allocated to connection

- 5.7 If an asset is reused following termination or allocated to connection when it has previously been allocated to TNUoS, a value needs to be determined for the purposes of connection charges. In both instances the connection charge will be based on the standard formula set out in paragraph 2.20. The Gross Asset Value will be based on the original construction costs and indexed by RPI. Where original costs are not known a reasonable value will be agreed between National Grid and the User based on similar types of asset in use. The Net Asset Value will be calculated as if the asset had been in continuous service as a connection asset from its original commissioning date taking into account the depreciation period.
- 5.8 Where an asset has been refurbished or updated to bring it back into service a new value and an appropriate replacement period will be agreed between National Grid and the User. This will be based on the value of similar types of asset in service and the costs of the refurbishment.

Chapter 6: Contestability

- 6.1 Some connection activities may be undertaken by the User. The activities are the provision, or construction, of connection assets, the financing of connection assets and the ongoing maintenance of those assets. While some Users have been keen to see contestability wherever possible, contestability should not prejudice system integrity, security and safety. These concerns have shaped the terms that are offered for contestability in construction and maintenance.

Contestability in Construction

- 6.2 Users wishing to provide (construct) connection assets have been able to do so since 1990. Formal arrangements for Users exercising this choice are available. Further information on User choice in construction can be obtained from the **Charging Team**.

Contestability in the Maintenance Service

- 6.3 The arrangements for contestability in the maintenance service will be the subject of a separate review involving Users and the transmission licensees.

Chapter 7: Asset Replacement

- 7.1 Appendix A of a User's Bilateral Connection Agreement specifies the age (number of complete charging years old), for charging purposes, of each of the GB connection assets at the Connection Site for the corresponding Financial Year. Connection charges are calculated on the assumption that the assets will not need to be replaced until the charging age has reached the duration of the asset's Replacement Period.

If a connection asset is to be replaced, National Grid will enter into an agreement for the replacement with the User. Where replacement occurs before the original asset's charging age has reached the duration of its Replacement Period, National Grid will continue to charge for the original asset and make no charge to the existing User for the new asset until the original asset's charging age has reached the duration of its Replacement Period.

Where the replacement occurs after the original asset's charging age has reached the duration of its Replacement Period, National Grid will charge on the basis of the original asset until replaced and on the basis of the new asset on completion of the works.

- 7.2 When the original asset's charging age has reached the duration of its Replacement Period the User's charge will be calculated on the then Net Asset Value of the new asset. The new asset begins depreciating for charging purposes upon completion of the asset replacement.

The Basic Annual Connection Charge Formulae are set out in **Chapter 2: The Basic Annual Connection Charge Formula**.

Asset Replacement that includes a change of Voltage

- 7.3 There are a number of situations where an asset replacement scheme may involve a change in the voltage level of a User's connection assets. These replacement schemes can take place over a number of years and may involve a long transitory period in which connection assets are operational at both voltage levels.
- 7.4 These situations are inevitably different from case to case and hence further charging principles will need to be developed over time as more experience is gained. Set out below, are some generic principles. This methodology will be updated as experience develops.
- 7.5 The general principles used to date are to ensure that, in the transitory period of an asset replacement scheme, the User does not pay for two full transmission voltage substations and that the charges levied reflect the Replacement Period of the original connection assets. In addition, in line with paragraph 7.1 above, charges will only be levied for the new assets once the original assets would have required replacement.
- 7.6 For example, a transmission licensee in investing to meet a future Security Standard need on the main transmission system, may require the asset replacement of an existing 275kV substation with a 400kV substation prior to the expiry of the original assets' Replacement Period. In this case, National Grid will seek to recover the connection asset component via connection charges when the assets replaced were due for asset replacement. Prior to this, the User should not see an increase in

charges and therefore the investment costs would be recovered through TNUoS charges.

In addition, if in the interim stage the User has, say, one transformer connected to the 275kV substation and one transformer connected to the 400kV substation, the charge will comprise an appropriate proportion of the HV assets at each site and not the full costs of the two substations. Note that the above described treatment is only made for transitory asset replacement and not enduring configurations where a User has connection assets connected to two different voltage substations.

Chapter 8: Data Requirements

- 8.1 Under the current connection charging methodology no data is required from Users in order to calculate the connection charges payable by the User.

Chapter 9: Applications

- 9.1 Application fees are payable in respect of applications for new connection agreements and modifications to existing agreements based on the reasonable costs transmission licensees incur in processing these applications. Users can opt to pay a fixed price application fee (derived from analysis of the historical costs of similar applications) in respect of their application or pay the actual costs incurred. The fixed price fees for applications are detailed in the **Statement of Use of System Charges**.
- 9.2 If a User chooses not to pay the fixed fee, the application fee will be based on an advance of transmission licensees Engineering and out-of pocket expenses and will vary according to the size of the scheme and the amount of work involved. Where actual expenses exceed the advance, National Grid will issue an invoice for the excess. Conversely, where National Grid does not use the whole of the advance, the balance will be refunded.
- 9.3 National Grid will refund application fees and consent payments made under the Construction Agreement either on commissioning or against the charges payable in the first three years of the new or modified agreement. The following conditions apply:
- The refund will be net of external costs;
 - Where a new or modified agreement is signed and subsequently modified at the User's request before any charges become payable, National Grid will refund the original application fee. National Grid will not refund the fees in respect of the subsequent modification(s).

Appendix 1: Illustrative Connection Charges

2005/2006 First Year Connection Charges based on the RPI Method (6% rate of return)

The following table provides an indication of typical charges for new connection assets. Before using the table, it is important to read through the notes below as they explain the assumptions used in calculating the figures.

Calculation of Gross Asset Value (GAV)

The GAV figures in the following table were calculated using the following assumptions:

- Each asset is new
- The GAV includes estimated costs of construction, engineering, Interest During Construction and Liquidated Damages premiums

For details of the Calculation of the Gross Asset Value, see Chapter 2 of this Statement.

Calculation of first year connection charge

The first year connection charges in the following table were calculated using the following assumptions:

- The assets are new
- The assets are depreciated over 40 years
- The rate of return is assumed to be 6% for RPI indexation
- The connection charges include maintenance costs
- The connection charges include Transmission Running Costs at a rate of 1.70% of the GAV

For details of the Basic Annual Connection Charge Formula, see Chapter 2 of this Statement.

Please note that the actual charges will depend on the specific assets at a site. Agreement specific NAVs and GAVs for each User will be made available on request.

Notes on Assets

The charges for Double and Single Busbar Bays include electrical and civil costs.

Transformer cable ratings are based on winter soil conditions.

In this example, transformer charges include civil costs of plinth and noise enclosure and estimated transport costs, but not costs of oil dump tank and fire trap moat. Transport costs do not include hiring heavy load sea transportation or roll-on roll-off ships.

	£000's					
	400kV		275kV		132kV	
	GAV	Charge	GAV	Charge	GAV	Charge
Double Busbar Bay	1929	205	1581	168	528	56
Single Busbar Bay	1534	163			387	41
Transformer Cables 100m (incl. Cable sealing ends)						
120MVA			734	78	235	25
180MVA	1122	119	734	78	242	26
240MVA	1148	122	742	79	250	27
750MVA	1164	124	856	91		
Transformers						
45MVA 132/66kV					887	94
90MVA 132/33kV					853	91
120MVA 275/33kV			1715	182		
180MVA 275/66kV			1855	197		
180MVA 275/132kV			1836	195		
240MVA 275/132kV			1597	170		
240MVA 400/132kV	1761	187				

Connection Examples
Example 1

NEW 132/33kV SUPERGRID CONNECTION
SINGLE SWITCH MESH TYPE

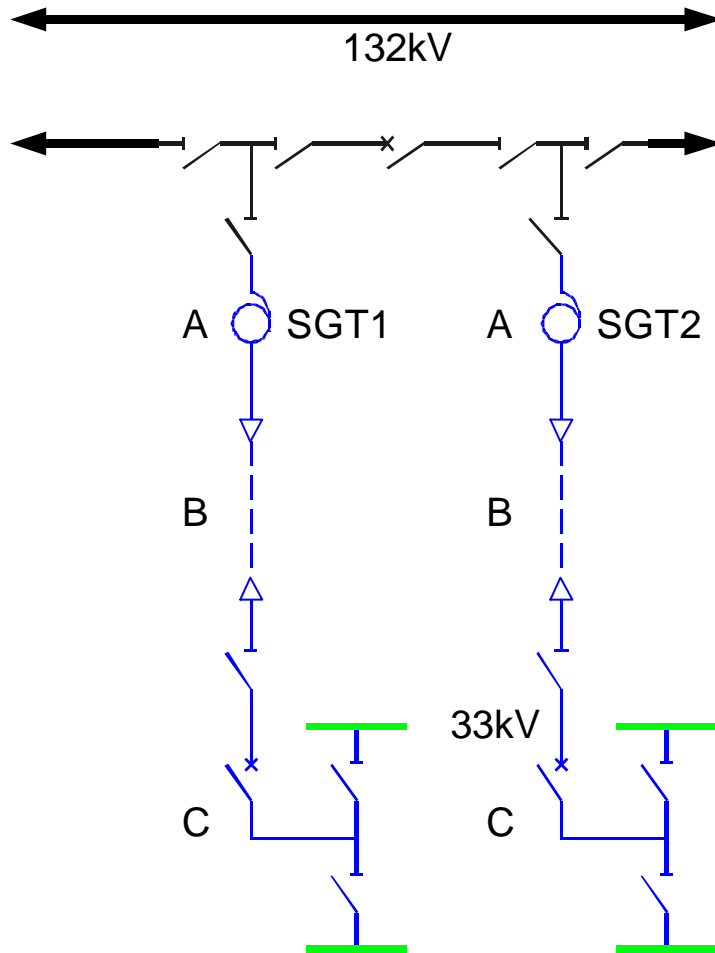

KEY:

- Existing Transmission Assets
- Proposed GB connection assets
- Customer Assets

SCHEDULE FOR NEW CONNECTION				
Ref	kV	No	Description	First Year Charges (£000s)
A	132//33	2	90MVA Transformers	188
B	33	2	100m(eg) 90 MVA Cables	16
C	33	2	Double Busbar Transformer Bays	18
Total				222

Example 2

**NEW 400/132kV SUPERGRID CONNECTION
SINGLE SWITCH MESH TYPE**

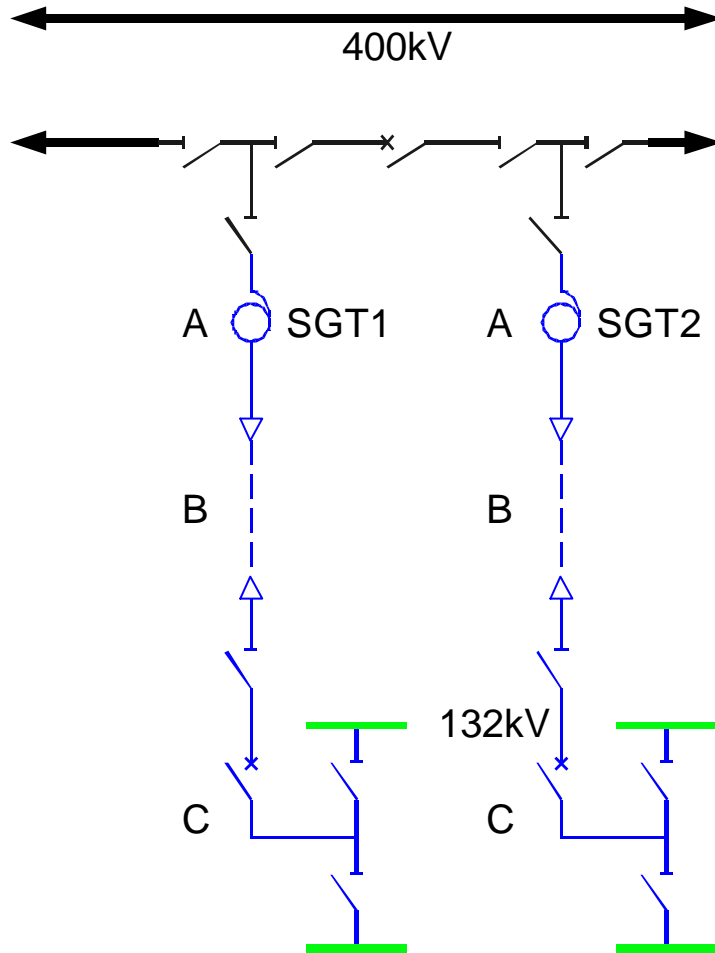

KEY:

- Existing Transmission Assets
- Proposed GB connection assets
- Customer Assets

SCHEDULE FOR NEW CONNECTION				
Ref	kV	No	Description	First Year Charges (£000s)
A	400/132	2	240MVA Transformers	374
B	132	2	100m(eg) 240 MVA Cables	54
C	132	2	Double Busbar Transformer Bays	112
Total				540

Example 3

**NEW 132/33KV SUPERGRID CONNECTION
DOUBLE BUSBAR TYPE**

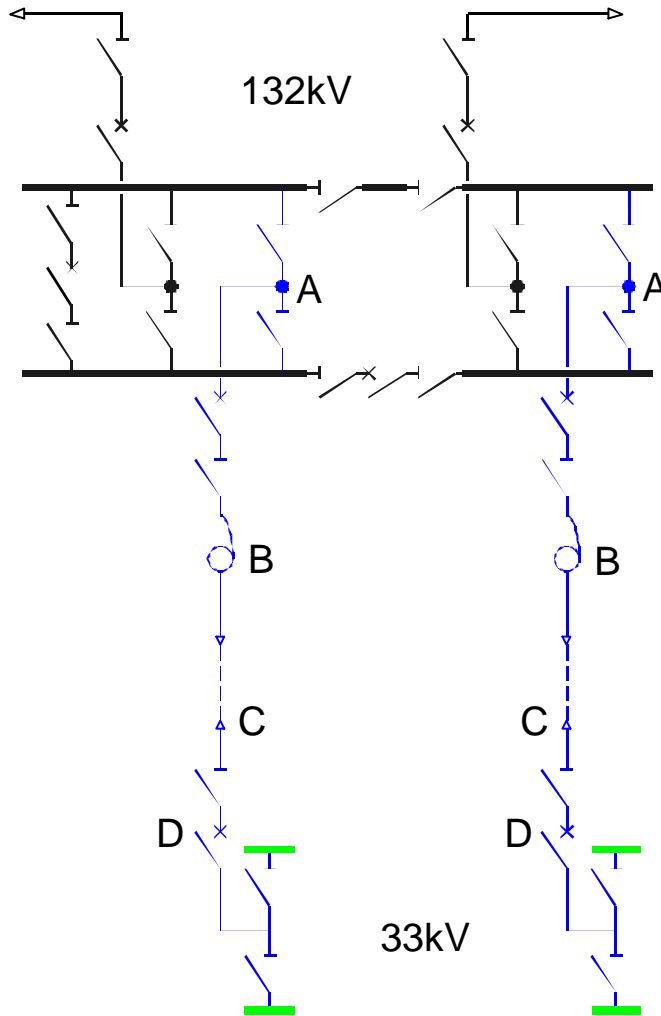

KEY:

- Existing Transmission Assets
- Proposed GB connection assets
- Customer Assets

SCHEDULE FOR NEW CONNECTION				
Ref	kV	No	Description	First Year Charges (£000s)
A	132	2	Double Busbar Transformer Bays inc. breaker	112
B	132/33	2	90 MVA Transformers	182
C	33	2	100m(eg) 90MVA Cables	16
D	33	2	Double Busbar Transformer Bays inc. breaker	18
Total				328

Example 4

NEW 400/132KV SUPERGRID CONNECTION DOUBLE BUSBAR TYPE

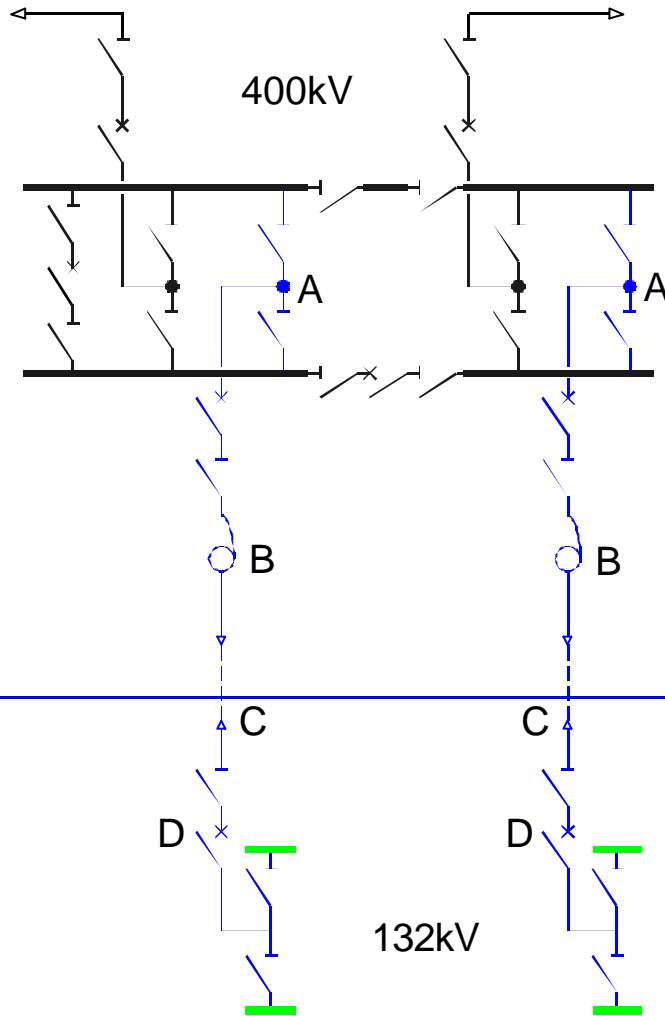

KEY:

- Existing Transmission Assets
- Proposed GB connection assets
- Customer Assets

SCHEDULE FOR NEW CONNECTION				
Ref	kV	No	Description	First Year Charges (£000s)
A	400	2	Double Busbar Transformer Bays inc. breaker	410
B	400/132	2	240 MVA Transformers	374
C	132	2	100m(eg) 240MVA Cables	54
D	132	2	Double Busbar Transformer Bays inc. breaker	112
Total				950

Appendix 2: Examples of Connection Charge Calculations

The following examples of connection charge calculations are intended as general illustrations.

Example 1

This example illustrates the method of calculating the first year connection charge for a given asset value. This method of calculation is applicable to indicative price agreements for new connections, utilising the RPI method of charging, and assuming:

- i) the asset is commissioned on 1 April 2005
- ii) there is no inflation from year to year i.e. GAV remains constant
- iii) the Transmission Running Cost component remains constant throughout the 40 years
- iv) the asset is depreciated over 40 years
- v) the rate of return charge remains constant at 6% for the 40 year life of the asset
- vi) the asset is terminated at the end of its 40 year life

For the purpose of this example, the asset on which charges are based has a Gross Asset Value of £3,000,000 on 1 April 2005.

Charge	Calculation	
Site Specific Maintenance Charge (for example 0.5% of GAV)	$3,000,000 \times 0.5\%$	£15,000
Transmission Running Cost (1.70% of GAV)	$3,000,000 \times 1.70\%$	£51,000
Capital charge (40 year depreciation 2.5% of GAV)	$3,000,000 \times 2.5\%$	£75,000
Return on mid-year NAV (6%)	$2,962,500 \times 6\%$	£177,750
TOTAL		£318,750

The first year charge of £318,750 would reduce in subsequent years as the NAV of the asset is reduced on a straight-line basis.

This gives the following annual charges over time (assuming no inflation):

Year	Charge
1	£318,750
2	£314,250
10	£278,250
40	£143,250

Based on this example, charges of this form would be payable until 31 March 2045.

Example 2

The previous example assumes that the asset is commissioned on 1 April 2005. If it is assumed that the asset is commissioned on 1 July 2005, the first year charge would equal 9/12th of the first year annual connection charge i.e. £239,062.50. Furthermore, a final charge would be payable on the 40th anniversary of the asset i.e. 30th June 2045.

For the purposes of this example, the asset on which charges are based has a Gross Asset Value of £3,000,000 on 1 July 2005. Given the assumptions outlined in example 1, the charge for the final year (that being the 41st year) shall be calculated as 3/12th of the charge calculated below.

Charge	Calculation	
Site Specific Maintenance Charge (for example 0.5% of GAV)	$3,000,000 \times 0.5\%$	£15,000
Transmission Running Cost (1.70% of GAV)	$3,000,000 \times 1.70\%$	£51,000
Capital charge (40 year depreciation 2.5% of GAV)	$3,000,000 \times 2.5\%$	£75,000
Return on mid-year NAV (6%)	$0 \times 6\%$	£0
TOTAL		£141,000

This gives the following annual charges over time:

Year	Charge
1	£239,062.50 (connection charge for period July to March)
2	£314,250.00
10	£278,250.00
40	£143,250.00
41	£35,250.00 (connection charge for period April to June)

A new User connecting to the system in July 2005 will pay 9/12th of the annual connection charge in the first year and 3/12th of the annual connection charge in year 41.

Example 3

In the case of a firm price agreement, there will be two elements in the connection charge, a finance component and a running cost component. These encompass the four elements set out in the examples above. Using exactly the same assumptions as those in example 1 above, the total annual connection charges will be the same as those presented. No increase or decrease in these firm connection charges will result from a change in the sharing of the assets, or from a different methodology of charging subsequently being adopted by National Grid.

Example 4

If a User has chosen a 20-year depreciation period for their Post Vesting connection assets and subsequently remains connected at the site beyond the twentieth year their charges are calculated as follows.

For years 21-40 they will pay a connection charge based on the following formula:

$$\text{Annual Connection Charge}_n = \text{SSF}_n (\text{RPIGAV}_n) + \text{TC}_n (\text{GAV}_n)$$

The NAV will be zero and the asset will be fully depreciated so there will be no rate of return or depreciation element to the charge.

Chapter 10: Nominally Over Equipped Connection Sites

- 10.1 This chapter outlines examples of ways in which a connection site can be considered as having connection assets that exceed the strict, theoretical needs of the individual Users at the connection site. These can be described as:

Historical

- 10.2 This is where the connection assets at the connection site were installed to meet a requirement of the Users for connection capacity that no longer exists. An example would be where a User, at one time, had a requirement for, say, 270 MW. This would allocate three 240 MVA 400/132kV transformers to the User. Due to reconfiguration of that User's network only 200 MW is now required from the connection site. The lower requirement would only allocate two transformers, but all the transformers are kept in service. The connection assets will continue to be assigned to the User's connection, and charged for as connection, until the User makes a Modification Application to reduce the historical requirement. In some cases the Modified requirement will mean that Termination Payments will have to be made on some connection assets.

Early Construction

- 10.3 If a User has a multi-phase project, it may be necessary to install connection assets for the latter phases at the time of the first phase. These connection assets could be charged from the first phase charging date.

Connection site Specific Technical or Economic Conditions

- 10.4 In circumstances where the transmission licensee has identified a wider requirement for development of the transmission system, it may elect to install connection assets of greater size and capacity than the practicable minimum scheme required for a particular connection. In these circumstances, however, connection charges for the party seeking connection will normally be based on the level of connection assets consistent with the practicable minimum scheme needed to meet the applicant's requirements.
- 10.5 There may be cases where there are specific conditions such that the practicable minimum scheme at a site has to be greater than the strict, theoretical interpretation of the standards. In these cases all assets will still be assigned to connection and connection charges levied.
- 10.6 A practicable minimum scheme is considered in terms of the system as a whole and may include a change in voltage level.

Glossary

The following definitions are intended to assist the reader's understanding of this document. In the event of conflict with definitions given elsewhere, those used in the Electricity Act 1989 (as amended by the Utilities Act 2000), Transmission Licence, Grid Code, Balancing and Settlement Code and Connection and Use of System Code take precedence.

Act	The Electricity Act 1989 as amended by the Utilities Act 2000 and the Energy Act 2004
Authority	The Gas & Electricity Markets Authority (Ofgem)
Balancing and Settlement Code (BSC)	As defined in the Transmission Licence
Bilateral Agreement	Means, in relation to a User, a Bilateral Connection Agreement or a Bilateral Embedded Generation Agreement between National Grid and the User, as defined in Standard Condition 1 of the National Grid Transmission Licence
Charging Date	As defined in the Construction Agreement of the Connection and Use of System Code (CUSC)
Commissioned	In respect of Plant and Apparatus commissioned before the Transfer Date means Plant and Apparatus recognised as having been commissioned according to the commissioning procedures current at the time of commissioning and in respect of Plant and Apparatus commissioned after the Transfer Date] means Plant and/or Apparatus certified by the Independent Engineer as having been commissioned in accordance with the relevant Commissioning Programme
Connection Entry Capacity (CEC)	As defined in the Connection and Use of System Code
Consents	In relation to any Works:- <ul style="list-style-type: none"> a) all such planning and other statutory consents; and b) all wayleaves, easements, rights over or interests in land or any other consent; or for commencement and carrying on of any activity proposed to be undertaken at or from such Works when completed c) permission of any kind as shall be necessary for the construction of the Works
Construction Agreement	An agreement entered into pursuant to Paragraph 1.3.2 of the CUSC
CUSC	The Connection and Use of System Code
Demand	Electricity consumed at sites or by equipment not owned and operated by the transmission licensees

Depreciation Period	In relation to a transmission licensee's Asset for a particular User, the period which commences on the asset's initial effective charging date, and which expires after the appropriate duration, which unless otherwise agreed upon connection is 40 years excluding FMS Metering Electronics that are agreed with the individual transmission licensee
Directly-Connected Customer	A large, usually industrial, consumer of electricity who is directly connected to the GB transmission system
Disconnect or Disconnection	<p>(a) permanent physical disconnection of the [User's Equipment] at the site of connection to the Distribution System;</p> <p>(b) permanent physical disconnection of a User's Equipment at any given Connection Site which permits removal thereof from the Connection Site or removal of all transmission licensee's Assets therefrom (as the case may be);</p> <p>(c) permanent physical disconnection of the User's Equipment or Equipment for which the User is responsible (as defined in Section K of the Balancing and Settlement Code) at the site of connection to the Distribution System</p>
Distribution voltage	A voltage of 132kV or below. Generally taken to be voltages lower than those defined as transmission voltages
Embedded	A direct connection to a Distribution System or the System of any other User to which Users and/or Power Stations are connected
Engineering Charge	As set out in the Statement of Use of System Charges from time to time
Exempt generator	Any generator who, under the terms of the Electricity (Class Exemptions from the Requirement for a Licence) Order 2001, is not obliged to hold a generation licence
Final Sums	As defined in the Construction Agreement
Financial Year	The period of 12 months ending on 31st March in each calendar year
GB Transmission System	The system consisting (wholly or mainly) of high voltage electric lines owned and operated by transmission licensees and used for the transmission of electricity from one Power Station to a substation or to another Power Station or between substations or to or from any External Interconnection and includes any Plant and Apparatus and meters owned by and operated by transmission licensees in connection with the transmission of electricity but does not include any Remote Transmission Assets

Generator	A person who generates electricity under licence or exemption under the Act
Grid Code	A document prepared by National Grid in accordance with Standard Condition 7 of the Transmission Licence setting out the technical parameters for the operation and use of the transmission system and of plant and apparatus connected to the transmission system
Grid Supply Point (GSP)	A point of delivery from the GB Transmission System to a distribution system or Non-Embedded User
Interconnector	Means apparatus, connected to the Total System from or to an External System
Licence standards	Standards listed in Condition AA2 of the Transmission Licence or otherwise registered with the Authority in accordance with which transmission licensees are required to plan, develop, operate and maintain the transmission system
Licensable Generation	Generating plant where the party generating electricity at that generating plant is required to hold a Generation Licence
Liquidated Damages	The sums specified in the Construction agreement
Mandatory Services Agreement	An agreement between National Grid and a User to govern the provision of and payment for Mandatory Ancillary Services
Modification	Any actual or proposed replacement, renovation, modification, alteration, or construction by or on behalf of a User or National Grid to either that CUSC Party's Plant or Apparatus or the manner of its operation which has or may have a Material Effect on another CUSC Party at a particular Connection Site
Ownership boundary	Shall be the boundary defined by Paragraph 1.6 in this document
Power Station	As defined in the Grid Code as: "an installation comprising one or more Generating Units (even where sited separately) owned and/or controlled by the same Generator, which may be reasonably considered as being managed as one Power Station."
Public Distribution System Operator	Any holder of a distribution licence who was the holder, or is a successor to a company which was the holder of a Public Electricity Supply Licence relating to the distribution activities in GB on the CUSC Implementation Date
Reasonable Charges	Reasonable cost reflective charges comparable to charges for similar services obtainable in the open market

Replacement Period	In relation to a transmission licensee's Asset, the period commencing on the date on which such transmission licensee's Asset is or was originally Commissioned, after which it is assumed for accounting purposes such a transmission licensee's Asset will need to be replaced, which shall be 40 years unless otherwise agreed between the parties to a Bilateral Agreement and recorded in the relevant Bilateral Agreement
Retail Price Index	Means the general index of retail prices published by the Office for National Statistics each month in respect of all items or: (a) if the said index for any month in any year shall not have been published on or before the last day of the third month after such month such index for such month or months as the parties hereto agree produces as nearly as possible the same result shall be substituted or in default of the parties reaching agreement within six weeks after the last day of such three month period then as determined by a sole Chartered Accountant appointed by agreement by both parties or in the absence of agreement on the application of either party by the President of the Electricity Arbitration Association who shall act as an expert and whose decision shall be final and binding on the parties; or (b) if there is a material change in the basis of the said index, such other index as the parties agree produces as nearly as possible the same result shall be substituted or in default of the parties reaching agreement within six weeks after the occurrence of the material change in the basis of the said index then as determined by the sole Chartered Accountant appointed by agreement by both parties or in the absence of agreement on the application of either party by the President of the Electricity Arbitration Association who shall act as an expert and whose decision shall be final and binding on the parties
Security Standard	GB Transmission System Security and Quality of Supply Standard
Small Power Station	Defined in the Grid Code as: "A Power Station with a Registered Capacity of less than 50MW."
Supplier	A holder of an electricity supply licence
Total System	Has the meaning given to that expression in the Electricity Generation Licence i.e. "...the transmission and distribution systems of all authorised electricity operators which are located in GB"
Trading Party	As defined in the Balancing and Settlement Code

Transfer date	31 st March 1990
Transmission Licences	The licences granted to National Grid, Scottish Power Transmission Ltd and Scottish Hydro Electric Transmission Ltd under Section 6(1)(b) of the Act
Transmission Licensees Assets	The Plant and Apparatus owned by transmission licensees necessary to connect the User's Equipment to the GB Transmission System at any particular Connection Site in respect of which National Grid charges Connection Charges (if any) as listed or identified in [Appendix A] to the Bilateral Agreement relating to each such Connection Site
Transmission Owner Activity	The function of a transmission licensees Transmission Business as defined in the Transmission Licence
Transmission voltage	Voltages above 132kV - usually 275kV and 400kV
User	A party that connects to or makes use of the GB Transmission System
Utilities Act 2000	Utilities Act 2000

Index to the Statement of the Connection Charging Methodology (Issue 1) Revisions

Issue 1	Modifications	Changes to Pages
Revision 0	New Issue	