

# Radio Teleswitch

---

*Nick Sillito*

# Overview

---

- ◆ **What is a Radio Teleswitch?**
- ◆ **What effect does Radio Teleswitching have on demand?**
- ◆ **What services might be provided?**
- ◆ **Service issues?**
- ◆ **Way forward**

# What is a Radio Teleswitch?



# "Simple" Teleswitch

---

- ◆ **Teleswitch replaces clock in Economy 7 systems**
- ◆ **Two modes**
  - ◆ **Peak rate power (storage heaters off)**
  - ◆ **Off peak power (storage heaters on)**
- ◆ **Cannot vary heating load time without varying peak/off peak times**

# "Simple" Teleswitch

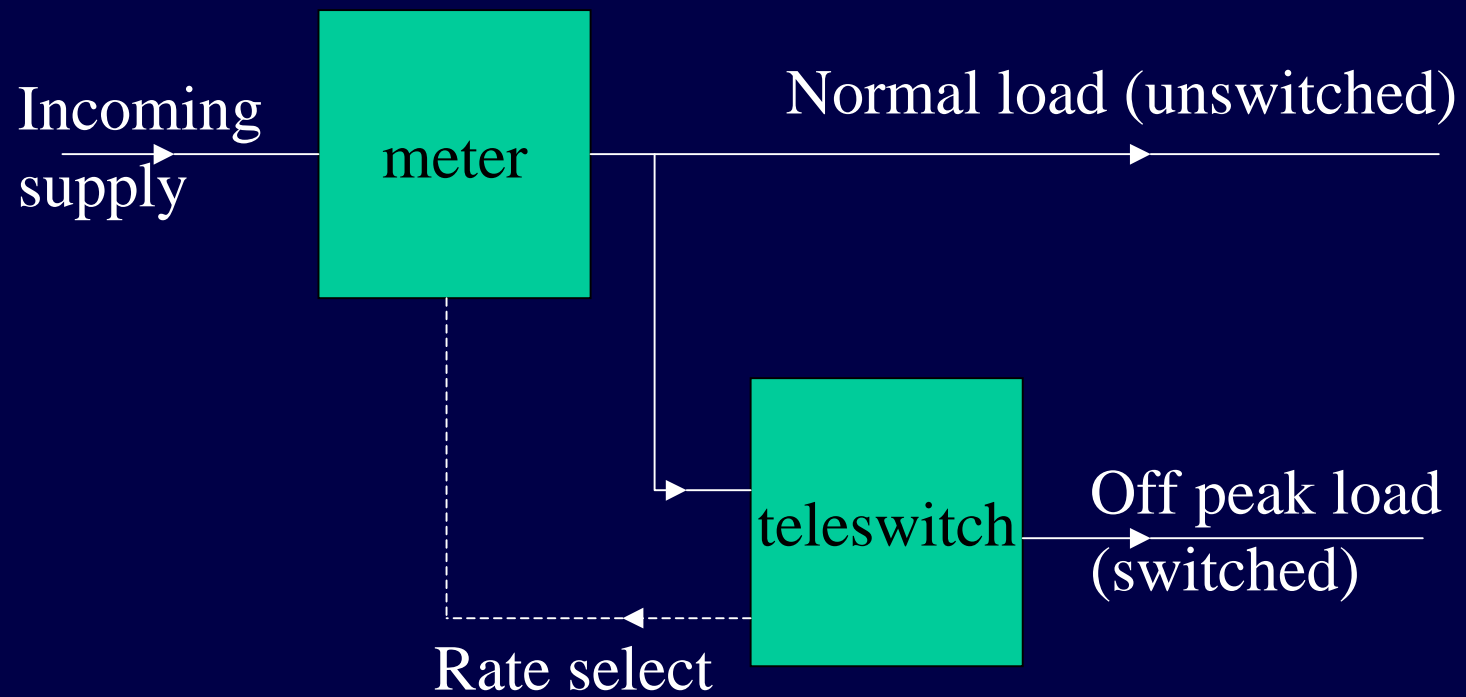

# “Double” Teleswitch

---

- ◆ **Twin teleswitch and meters**
- ◆ **Heating load is independent of tariff changes**
- ◆ **Able to offer:**
  - ◆ **X hours of heating per day**
  - ◆ **Fixed peak/off peak times**

# "Double" Teleswitch

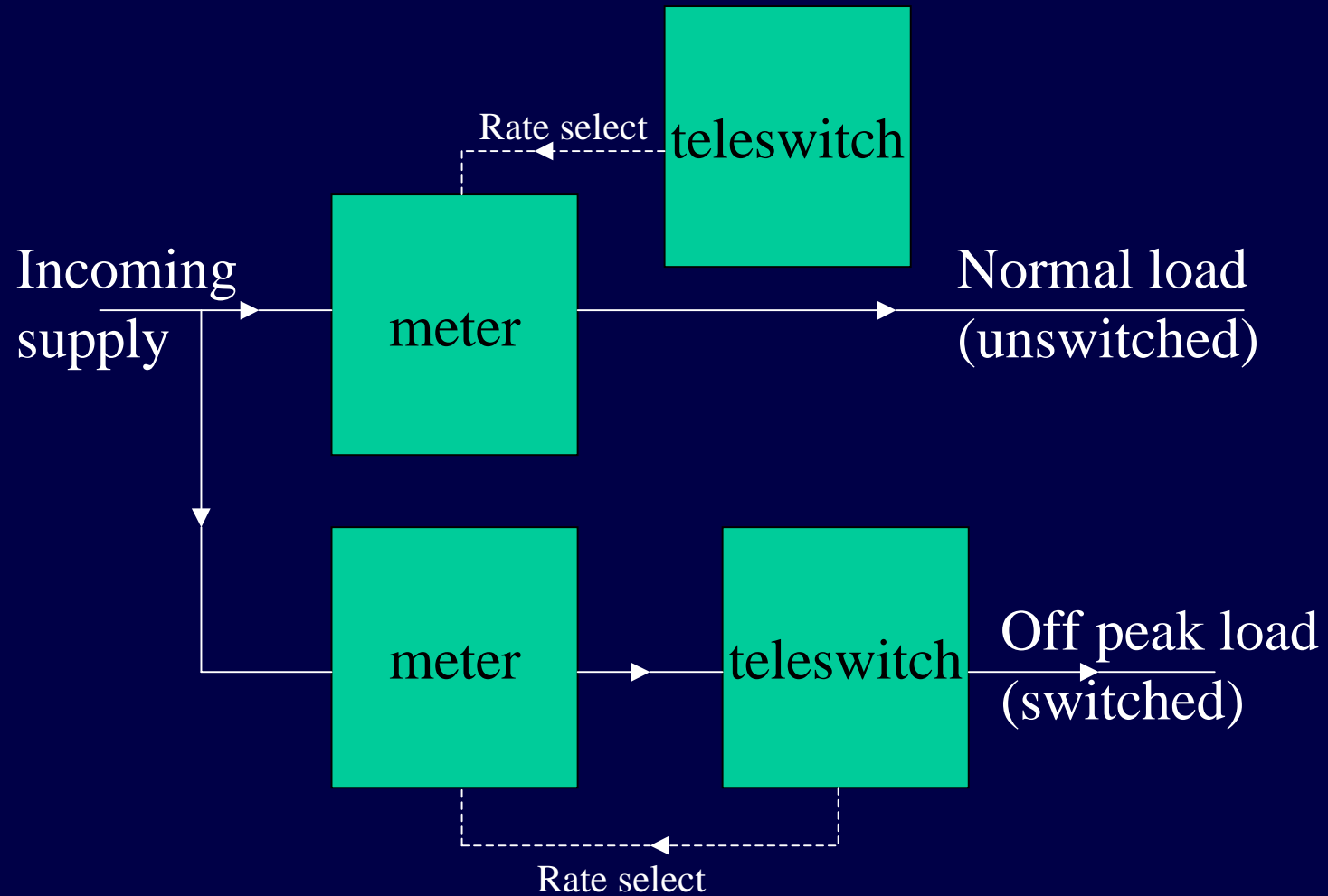

# Potential Teleswitch Services

---

- ◆ **“Flattening” the load curve**
  - ◆ **Short term despatch**
  - ◆ **Long term agreed profiles**
- ◆ **Other services?**

# “Flattening” the Load Curve

---

- ◆ **Rapid changes in demand have to be met with flexible plant**
- ◆ **Can lead to high imbalance charges**
- ◆ **Smoother load curves**
  - ◆ **reduce need to call flexible plant**
  - ◆ **reward variable demand**

# "Flattening" the Load Curve

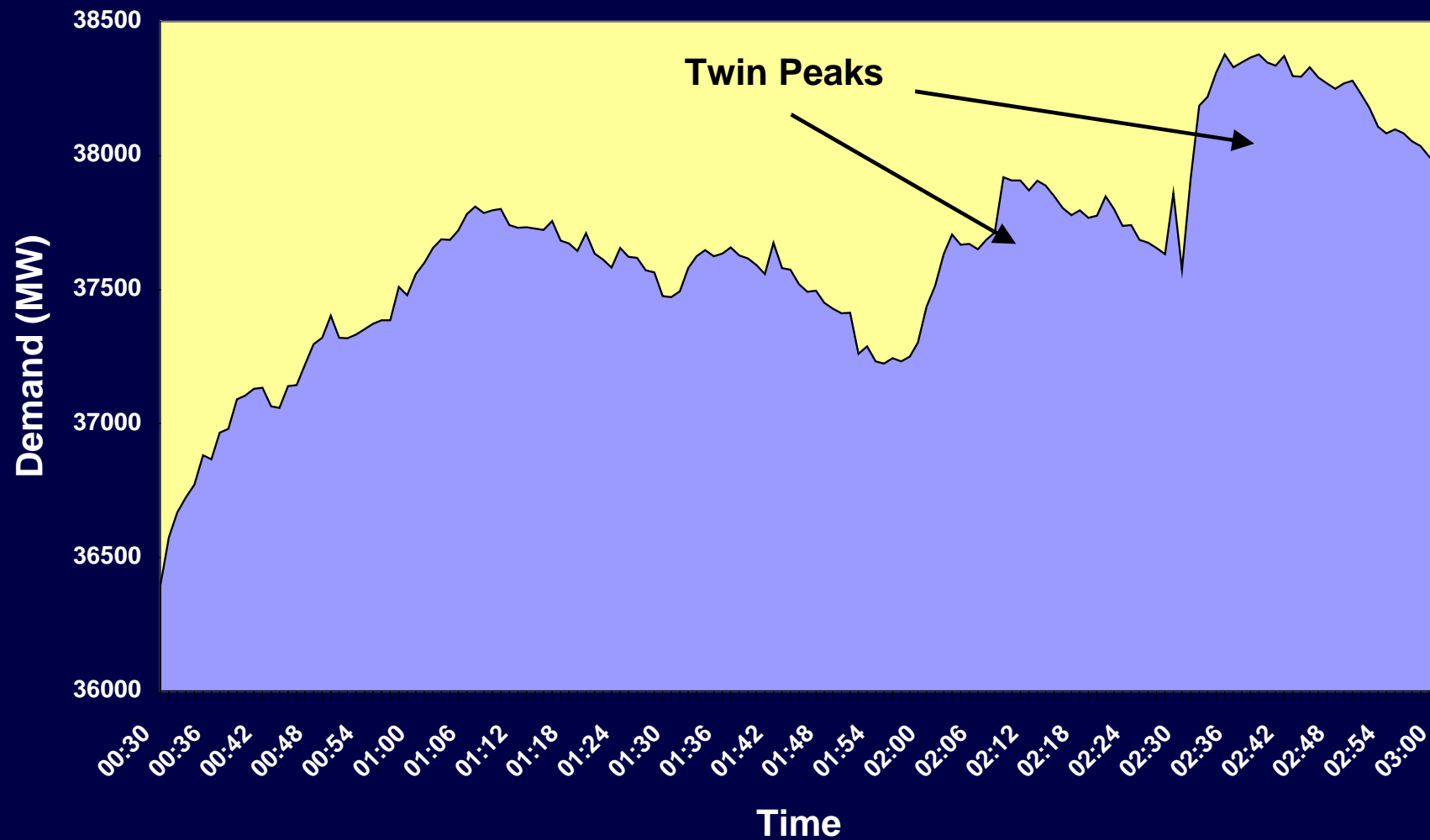

# "Flattening" the Load Curve

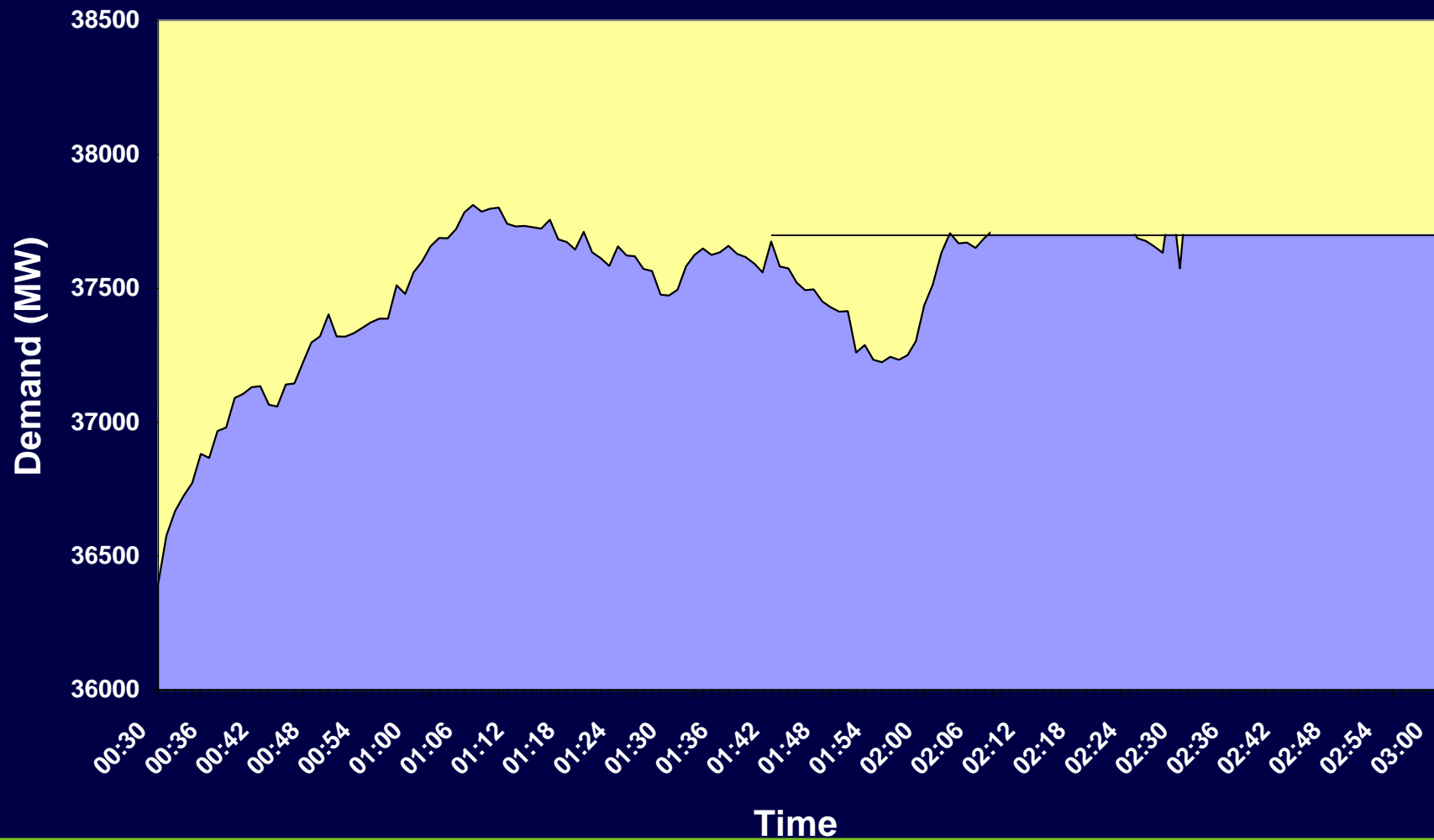

# "Flattening" the Load Curve

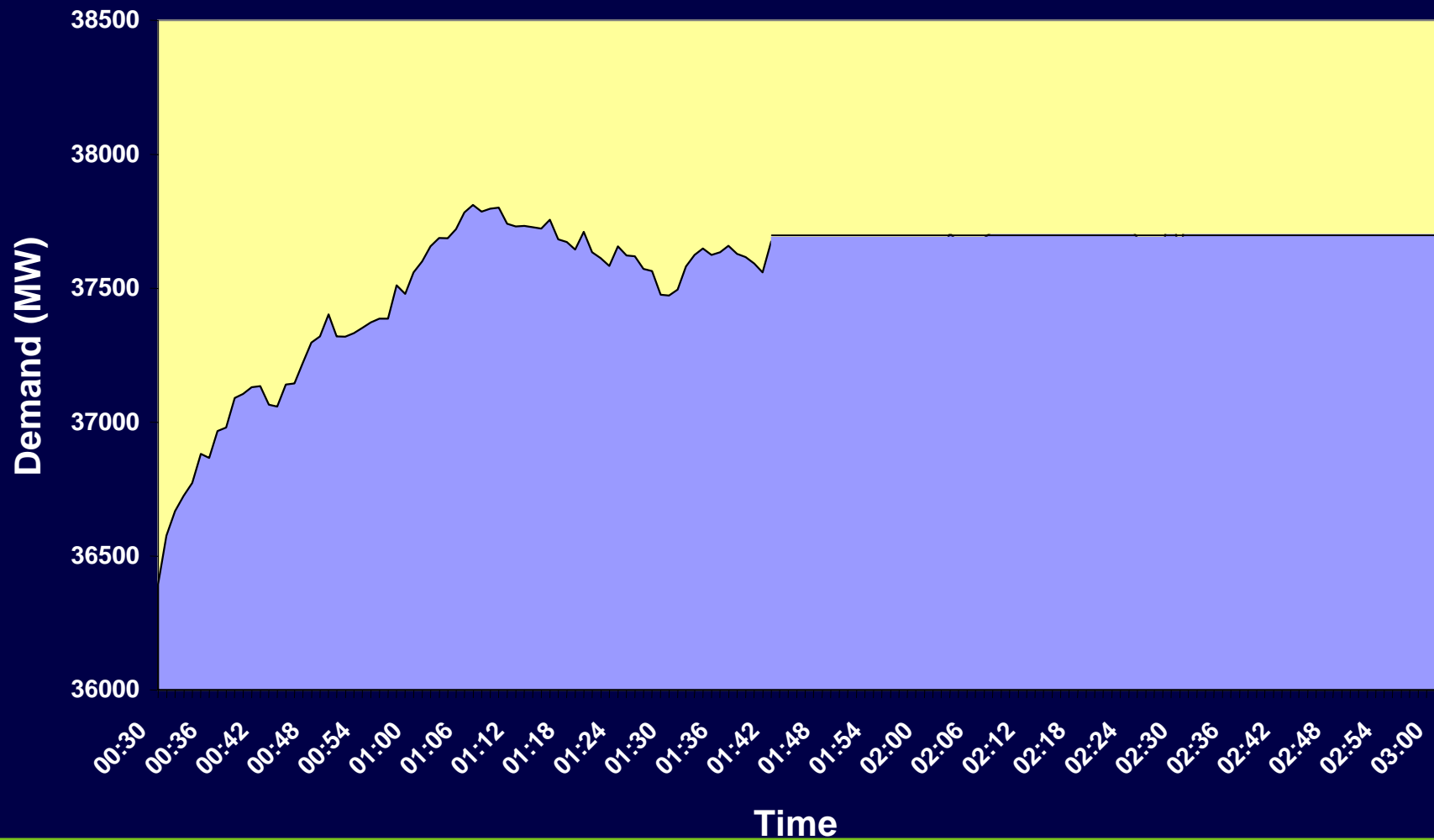

# Potential Service Issues

---

- ◆ **Customer impact**
- ◆ **Managing service despatch**
- ◆ **Metering**

# Way forward

---

- ◆ **Discuss potential services with Suppliers**
- ◆ **Potentially trial contracts for this winter**
- ◆ **Develop long term arrangements**
- ◆ **Any feedback?**