

**THE NATIONAL GRID COMPANY plc**  
**GRID CODE REVIEW PANEL**  
**GENERIC PROVISIONS WORKING GROUP**

**Introduction**

1. This paper proposes revision of the Grid Code to clarify the obligations on Generators utilising technology other than synchronous machines and on operators of DC Converter Stations. The Generic Provisions Working Group includes representatives nominated by Generators, Transmission Operators, Distribution Network Operators, British Wind Energy Association (BWEA) and wind farm developers. Also Ofgem is present as an observer. The Working Group members are listed in Appendix 1.
2. Although wind turbine manufactures were not present on the group, National Grid consulted with five large European manufacturers namely NEG Micon, Bonus Energy, Vestas, Enercon and GE Wind. To meet the manufacturers concerns on commercially sensitive information, National Grid was obliged to agree confidentiality with these companies.

**Background**

3. With the changes in Government energy strategy to increase the proportion of electricity generated from renewable sources, the number of power stations using generation technology other than “synchronous” machines is set to increase dramatically. Early discussions between National Grid and potential developers of new generation (mainly wind farms), indicated that there was a lack of clarity in the Grid Code on the requirements that new plant employing non-synchronous generation technologies were obliged to meet and some doubt on the technical capabilities of the emerging technology.
4. The Grid Code Generic Provisions Working Group was established following the acceptance of paper GCRP 02/21 at the 5 September 2002 meeting of the Grid Code Review Panel. Paper GCRP 02/21 recommended that the Working Group would propose revisions to the Grid Code to clarify the Connection Conditions in relation to the requirements on new generation technologies and modify other sections of the Grid Code to ensure continued clarity and consistency. Paper GCRP 02/21 asked the Working Group to take into account the recommendations of the HVDC Working Group as reported to the Grid Code Review Panel in paper 02/31 tabled at the November 2002 GCRP meeting, which relate to new HVDC Interconnectors.
5. The Working Group undertook to report back to the Grid Code Review Panel at the May 2003 meeting proposing detailed drafting changes for the Grid Code.

**Scope of Work**

6. The Generic Provisions Working Group has met on six occasions to develop the proposed revisions to the Grid Code. The full terms of reference for the Working Group can be found in Appendix 2. The general aim was to develop generic provisions to include changes for all existing and anticipated

generation systems and interconnector technology developments for both constant and intermittent energy sources.

7. The high level principles followed in order to meet this objective were:-
  - (a) Maintain transmission system security, stability and quality of supply,
  - (b) Avoid undue discrimination between Users and classes of Users taking due regard of the economic impact of requirements,
  - (c) Phase in the requirements to allow the generation technology to continue to develop and mature consistent with transmission system security needs,
  - (d) Involve input from all stakeholders including Generators, BWEA, wind farm developers, DNOs, and other transmission operators,
  - (e) Be aware of existing technical requirements of overseas utilities and their relevance to the England and Wales technical context,
  - (f) Ensure that the requirements help to facilitate the growth in renewable generation technologies in the medium and long term in line with the Government target, and
  - (g) Ensure that the requirements are transparent and clear and attempt to minimise Grid Code wording changes as practically as possible,
  - (h) Specify requirements functionally at the connection point, where possible, in order to maximise the Generators flexibility in choosing how to meet the requirements.
  
8. As a consequence the final proposals can be summarised as follows:
  - i) no change to the requirements on "synchronous" generating units,
  - ii) redrafting to clarify the application of existing requirements in relation to DC Converters and developing renewable generation technology,
  - iii) codifying capabilities required for secure system operation that are inherent for synchronous machines but cannot be assumed for other technologies.

### **Discussion of Major Issues**

9. The Generic Provisions Working Group explored a number of issues regarding the current and future capabilities of the new generation technologies. These issues are summarised below and discussed in detail in the Appendices. Of these, Fault Ride Through, Stability and Loss of Power Infeed and Frequency Range remained requirements that some members of the working group were unable to endorse.

#### Reactive Capability

10. In order to transmit active power on an AC transmission system there is a technical need for reactive support to be provided. In the case of synchronous generators, the need to remain transiently stable results in some inherent reactive capability being available within the generator. This may not be the case with some non-synchronous generation technologies where additional equipment may have to be provided to give a controllable reactive power capability range. In addition, the user network that may be associated with non-synchronous generation developments may have a significant effect on the reactive characteristics seen at the interface with the transmission system.

11. The attached reactive capability proposals (CC6.3.2) have been drafted to reflect both the needs of the transmission system in terms of security and quality of supply and the need to allow the continued development of the new technologies to provide improved capability. To allow time for this and to provide an appropriate signal of the transmission system requirement in the longer term, a staged introduction of the requirements is proposed. Initially, the non-synchronous generation would be required to be capable of operating at unity power factor at the connection point. From 1<sup>st</sup> January 2006, the requirement to have a symmetrical capability between a leading and lagging power factor of 0.95 at the connection point would be introduced in line with the Reactive Power Working Group's recommendations.
12. The proposals for conventional current-sourced DC Interconnectors are based on the recommendations of the HVDC Working Group. A more detailed discussion of the issues can be found in Appendix 3.

#### Frequency Range

13. Under normal system operating conditions NGC is required to control the system frequency within the statutory range of 49.5Hz to 50.5Hz. However, the Grid Code specifies that all generating plant should also be able to operate between a wider frequency range of 47Hz to 52Hz. This requirement is tied to the national transmission system frequency defence plan where low frequency demand disconnection relays are provided as an emergency network security protection and resilience plan against a full or partial system blackout situation.
14. During a severe incident such as a break up of the transmission system into power islands with deficits in generation can cause system frequency to fall to 47Hz causing demand to be shed by operation of the national transmission system frequency defence plan. The discrete nature of this scheme can, in turn, cause system frequency to overshoot and rise transiently to 52Hz. Therefore, it is very important that wind farms are not disconnected down to 47Hz or up to 52Hz otherwise the number of consumers whose supply would be disconnected would be increased leading, in the worst case, to a total system blackout situation. A more detailed discussion of the issues can be found in Appendix 4.

#### Frequency Response

15. The NGC Security and Quality of Supply Standard reflect the obligations on National Grid to maintain system frequency in line with The Electricity Safety, Quality and Continuity Regulations 2002. In order to achieve this, Generators are required by the Grid Code to have the capability to vary power output in response to changes in system frequency. Substantial and ongoing advances in wind farm generation technologies are reaching the point such that frequency response capability can be designed into modern wind farms. Also the anticipated number of such plant to be connected is such that there is a system need to ensure that response capability is provided. Overseas utilities have already begun specifying a requirement for a frequency response capability and at least one renewable generation project has been commissioned with such a facility.
16. National Grid proposes that the full existing requirements in the Grid Code to encompass non-synchronous generating technologies from 1<sup>st</sup> January 2006 with plant capable of providing limited frequency sensitive mode operation

immediately. A more detailed discussion of the issues can be found in Appendix 5.

#### Fault Ride Through

17. The NGC Security and Quality of Supply Standard (SQSS) used for planning and operating the transmission system restricts the maximum generation loss for any secured event to 1320MW. The system is therefore designed and operated so that any credible fault (and subsequent switching out of transmission system plant to clear the fault) will not cause the disconnection of more than 1320MW of generation. Since a fault may cause large system voltage depression down to as low as zero at the point of fault, any neighbouring generation will see a short term reduction in voltage which is dependent on the proximity of the fault. While a synchronous generator is inherently able to "ride through" such transient conditions, some types of non-synchronous technologies may trip. Manufacturers have been made aware of this requirement not to trip by NGC and developers and have been developing and improving the technology to overcome this issue. Similar capabilities are now required by many overseas utilities. Disconnection of generation in excess of 1320 MW could cause widespread customer demand disconnection by the national frequency defence plan.
18. The consequences of not having a fault ride through capability would result in one or more of the following:-
  - increased risk of widespread customer disconnection.
  - restriction on generation development in some geographic areas.
  - substantial increase in balancing costs for holding additional frequency response, ultimately paid for by customers.
19. As described above, fault ride through has important implications for the security and economics of electricity supply in England and Wales. In view of this and the development of similar requirements by other utilities, National Grid believes these requirements to be reasonable, even though it is acknowledged that there may be technical issues associated in meeting this requirement for a particular type of non-synchronous generator technology. A more detailed discussion of the issues can be found in Appendix 6.

#### Stability and Loss of Power Infeed

20. The NGC SQSS includes criteria for the connection of a power station which have particular relevance here. Following a secured Fault Outage, there shall not be :
  - i) Insufficient Voltage Performance Margins
  - ii) System Instability
  - iii) Any Loss of Power Infeed.Note : The above terms are defined in the SQSS
21. In general, the inherent characteristics of synchronous machines are such that these requirements are rarely an issue and therefore no specific, explicit requirements are deemed to be necessary in the Grid Code. However, for other types of technology where the response to a Fault Outage is less clear, it is important to ensure that the requirements in the SQSS continue to be satisfied, particularly those identified above.

22. It should be noted that 20(iii) above in practice requires the mechanical power during and immediately after a fault to be nominally constant. This is virtually the case for synchronous machines where the mechanical power slightly and very transiently, reduces through normal governor action as the speed transiently increases by a small amount. Similarly, if it were the case for induction machine technology that no deliberate control action in response to a fault to reduce mechanical power was taken during and immediately after the fault duration, it is apparent that no significant Loss of Power Infeed would occur. Obviously, a certain amount of natural or normal control action could occur for other purposes during the short time of the fault and immediately after. However, as with governor action for synchronous machines, this should be relatively small.
23. It was decided to include the specific requirement regarding no deliberate action to be taken to reduce prime mover mechanical power output as it is apparent that some wind-turbine manufacturers could consider doing so by fast pitch control to prevent over-speeding in some circumstances. In order to prevent a Loss of Power Infeed occurring, such control action would need to be inhibited for the relatively small speed deviation which would occur during a fault condition.
24. All of the above is relevant to non-synchronous generating units. However, for DC Converters, these can easily be designed to recover from faults very quickly both in terms of power and voltage but this may be too quick for the system in the vicinity. It would therefore seem reasonable that the fault recovery characteristics should be site specific and therefore specified in the Bilateral Agreement. The purpose of the site specific requirements is therefore to ensure the co-ordination of the converter recovery with the capabilities of the system by controlling the recovery characteristics. In practice, this will always mean slowing down recovery rates from what could actually be achieved and therefore should not impose any constraints on the converter design.

### **Outline of Proposed Grid Code Revisions**

25. While the full text of the proposed Grid Code revisions can be found in Appendix 8 the proposed changes are outlined as follows:-
26. Glossary & Definitions  
Additional and revised definitions to cover windfarms and other renewable energy parks (Power Park Modules) and DC Interconnectors (DC Converter Stations)
27. Planning Code  
Addition of the detailed data required for Power Park Modules and DC Converter Stations added in the Appendices.
28. Connection Conditions  
Generally clarifications to explicitly include Power Park Modules and DC Converter stations in existing clauses. Additions in CC6.3 to clearly state requirements on non-synchronous technology.
29. Operating Codes  
Generally clarifications to explicitly include Power Park Modules and DC Converter stations in existing clauses. Addition of Power Park Planning Matrix and generator performance chart at HV connection point in OC2.

30. Balancing Codes

Generally clarifications to explicitly include Power Park Modules and DC Converter stations in existing clauses. Addition of requirement for Power Park Matrix in BC2. BC3 updated to include recommendations of HVDC Working Group.

31. Data Registration Code

Additional data items for Power Park Modules and DC Converters added.

**Recommendation**

32. The Grid Code Review Panel is invited to
- consider the proposed Grid Code revisions
  - comment on the proposed revisions
33. Having considered comments from GCRP members, National Grid intends to initiate a wider consultation on the proposed Grid Code provisions.

National Grid Company plc  
Date

**Appendix 1 – Membership of Generic Provisions Working Group**

<u>Name</u>		<u>Company</u>
David Payne	(DP)	National Grid (Chairman)
Nasser Tleis	(NT)	National Grid
Steve Mortimer	(SM)	National Grid
Mark Horley	(MH)	National Grid
Mike Thorne	(MT)	National Grid
Hamish Dallachy	(HD)	Scottish Power
Peter Lang	(PL)	Seeboard
John Norbury	(JN)	Innogy
Ham Hamza	(HH)	Innogy
John France	(JF)	Powergen
Paul Newton	(PN)	PowerTech
Dave Ward	(DW)	Magnox
John Morris	(JM)	British Energy
Charlie Zhang	(CZ)	London Power Company
Francois Boulet	(FB)	RTE
James Glennie	(JG)	BWEA
Elaine Grieg	(EG)	AMEC
Bridget Morgan	(BM)	Ofgem (Observer)
Additional input:		
John Gaffney	(JG)	Innogy
Joe Duddy	(JD)	RES

## Appendix 2 – Terms of Reference

### Grid Code Review Panel - Generic Provisions Working Group (GPWG)

#### TERMS OF REFERENCE

##### 1. Objectives

The following two basic objectives have been identified as a viable starting point. However, subsequent investigations may lead to these being modified depending on outcomes :

- Develop generic provisions to include for all existing and anticipated generation systems and interconnector technology developments where a 'constant' source or sink of energy is normally available. This will consider embedded and direct transmission system connection together with the technical interaction and operational co-ordination issues.
- As above, but where an 'intermittent' source or sink of energy is normally available.

##### 2. Membership and Reporting

The group **GPWG** will comprise: -

Chairman (National Grid )  
Secretary (National Grid)

A N Others – GCRP Representatives or other nominees

The Chairman of the group will report to the **GCRP** on the work progress.

##### 3. Deliverables

The group will produce: -

Grid Code change proposals as part of a report that covers the objectives of the Working Group and how these were met.

##### 4. Timescales

A kick –off meeting is planned for mid-October 2002 at National Grid House.

A brief progress report would be produced for the 6th February 2003 GCRP meeting.

A final report and Grid Code change proposals would be produced for the 22nd May 2003 GCRP meeting.

### **Appendix 3 - Reactive Capability**

The Working Group considered at length the way in which reactive power capability should be specified.

#### Background

Voltage and reactive power control are required for the following reasons;

- a) protect plant and equipment from damaging over voltages,
- b) facilitate transfer of active power,
- c) maintain adequate voltage quality at the point of connection to customers.

Unlike active power, reactive power cannot be transmitted efficiently across large distances and has to be supplied locally to meet the above three reasons.

While a synchronous machine has an inherent capability to provide a controlled reactive power output resulting from the need to ensure stable synchronous operation, the basic induction generator employed in many existing small size wind farms does not. An induction generator absorbs reactive power from the host network. Further, a wind farm may contain a considerable network that will have its own reactive characteristics that will vary with loading. Where large cable lengths are present, the wind farm may naturally spill reactive power on to the host network.

The uncontrolled absorption of reactive power from the host network by a wind farm would have the effect of depressing system voltage in the local area of connection. Conversely the uncontrolled generation of reactive power by a wind farm would have the effect of raising local system voltage. In order to control voltage quality to customers additional reactive support may then be needed from other generators or from dedicated reactive compensation plant assuming this is available in the area. National Grid believes that to maintain quality of system voltage and avoid unfairness to other users of the transmission system, some reactive capability requirement should be placed on wind farm generators. This provides the opportunity to share in reactive market opportunities.

#### Method of Specification

Although including a minimum capability specification in the Bilateral Agreement on a site specific basis was considered, the Working Group considered that this was undesirable for the following reasons:

- not transparent to users
- could result in unequal treatment
- is difficult for a connecting Generator to assess potential requirement
- could result in a Generator having a very large reactive requirement in excess of the current Grid Code limits placed upon it, although this could be capped
- unclear division of reactive power capability provision responsibilities between Generator and Network Operator.

Including a clear generic minimum requirement in the Grid Code was seen to offer the following benefits:

- transparent to all system users
- ensures fair and equitable treatment
- limits the obligation on a generator to provide reactive power capability range
- provides a clear division in responsibility between network operator and generator to provide reactive power capability
- clear specification to developers.

Proposals Considered

A number of reactive capability proposals were considered by the Working Group for inclusion in the Grid Code.

These can be summarised as:

- Option 1 – Capability of +/- 0.92 power factor at the HV connection point. This is nominally equivalent to the current requirement for synchronous machines.
- Option 2 – Capability of +/- 0.95 power factor at the HV connection point. This is similar to Option 1 but with the range reduced in line with Grid Code Reactive Power Working Group recommendations.
- Option 3 – Capability of unity power factor. Based on the recommendations of the Grid Code HVDC Working Group and similar to the bare minimum operational requirements of the Grid Code Reactive Power Working Group.
- Option 4 – Capability at the connection point resulting from +/- 0.95 power factor at the individual unit LV terminals. The capability always includes unity power factor at the connection point.

The four options are illustrated below.

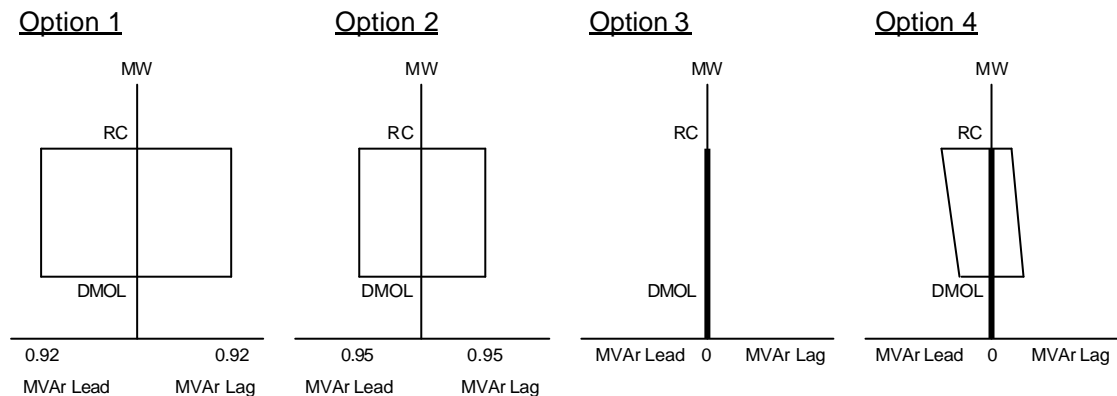

The advantages and disadvantages of the four options are considered below

Option	Pros	Cons
1	Consistent with the current requirements for synchronous machines.	Difficult to justify as in excess of recommendations of the Grid Code Reactive Power Working Group.
	Positive long term signals to developers.	May need some thyristor control of reactive compensation if older generation of wind turbine generators used.
	Avoids long term issues on reactive power provision.	Maybe potentially costly on developers
2	Less cost implications for developers particularly if current generation of wind turbine technology used.	Inconsistent with the current requirements for synchronous machines.
	Consistent with bulk of manufacturers claim that they can provide at least this range at the individual machine terminals.	May need some thyristor control of reactive compensation if older generation of wind turbine generators used.
	Easier to meet for controllable equipment than option 1.	May be some issues on future reactive power provision for National Grid.

3	Minimum demand on developers and therefore least developer cost.	Potential for major implications on long term procurement of reactive power by the transmission operator.
	Suitable for older generation of non-synchronous generation technology.	Potential cost penalties on transmission operation.
	Consistent with bare minimum operational recommendations of the Reactive Power Working Group.	Operational difficulties for control of transmission system voltage.
4	Development of Option 3.	The lead & lag reactive capability not known to National Grid at the application stage.
	Simple specification for developer and manufacturer.	Range eventually made available may not be of practical use to network operator.
	Capability incorporated at machine terminals may give better dynamic performance	Less useable capability than options 1 & 2.
	May provide some consequential capability at the Connection Point based on machine capability.	Appears to be designed around a specific existing generator type so potential disadvantages to some manufacturers or developers using other technology.

Having considered these four options, National Grid has proposed a time staged development of the Grid Code based on Options 2 and 3. This can be summarised as:

Wind farms, non-synchronous generating units and DC converters with completion dates prior to 1 January 2006 would be required, as a minimum, to be capable of operating to an instruction for zero MVAR transfer at the connection point. To ease this requirement further, a tolerance around the dispatch instruction would be acceptable and this would be specified at the connection offer stage in the Bilateral Agreement.

Wind farms, non-synchronous generating units and voltage-sourced DC converters with completion dates after 1 January 2006 would be required to meet the requirements of Option 2.

The decision not to increase the reactive capability requirement on conventional current-sourced DC converter technology is based on the following:

- compared to wind farms, the expected future market penetration is very low. No current-sourced DC converter station has connected to the NGC transmission system since 1986 and only one such DC converter station has a commitment for connection.
- DC converter stations utilising developing voltage-sourced technology are capable of reactive power regulation in a similar manner to most wind farm technologies.

#### **Appendix 4 – Frequency Range**

The National Grid transmission system operates to a nominal frequency of 50Hz by balancing generation and demand continuously on a second by second basis. System frequency is uniform across the total electricity system in Great Britain and at privatisation the obligation to control system frequency was placed on NGC.

NGC is required to control the system frequency within the statutory range of 49.5Hz to 50.5Hz under normal system operating conditions. However to ensure continued transmission network security under some abnormal operating conditions, the Grid Code specifies that all generating plant should also be able to operate, i.e. not to be disconnected, between a wider frequency range of 47Hz to 52Hz.

This requirement is tied to the national transmission system frequency defence plan where low frequency demand disconnection relays are provided as an emergency network security protection and resilience plan against a full or partial system blackout situation. Therefore, it is very important that wind farms are not disconnected down to 47Hz otherwise the number of consumers whose supply would be disconnected would be increased leading, in the worst case, to a total system blackout situation.

The discrete nature of the operation of the national transmission system frequency defence plan can in turn cause system frequency to overshoot and rise transiently to 52Hz. Therefore, it is very important that wind farms are not disconnected up to 52Hz otherwise the number of consumers whose supply would be disconnected would be increased leading, in the worst case, to a total system blackout situation.

Under the Grid Code, all generation projects above 50MW, irrespective of type, that connect to the transmission or distribution networks, are required not to be disconnected over this 47Hz to 52Hz frequency range. Although a slight relaxation from the upper frequency range, where evidence from developers showing the plant not to have the full capability, might be judged as acceptable, substantial relaxation would increase the risk of additional customer demand disconnection and size of blackout.

## **Appendix 5 – Frequency Response**

### Background

One of the principal requirements of the Electricity Safety, Quality and Continuity Regulations 2002 requires that there should not be a permanent change in system frequency outside the statutory limits of 50 Hz +/- 0.5Hz in the event of any of the contingencies defined in the licence standards occurring.

In order to achieve this, a frequency response service is required from generating plant. Generating plant providing this service is required to vary active power output in response to changes in system frequency. Because electricity cannot be stored in sufficient quantities, supply and demand have to be balanced instantaneously so automatic frequency control is necessary.

Under the Grid Code, all Power Stations with an installed capacity of 50MW or more are required to be capable of providing frequency response. Some nuclear generation designed and built before 1990 was exempted on design safety grounds from frequency response provision but not from limited frequency sensitive operation.

### Wind Farm Frequency Response Capability

Historically generating units within wind farms have been simple induction generators with no control over the power extracted from the wind (commonly referred to as passive stall turbines). However, in recent years to improve efficiency, developments have taken place allowing turbines to control the power extracted (commonly known as active stall or variable speed pitch controlled turbines). Therefore this generation technology has a latent capability to providing frequency response by controlling the electrical power output in relation to the maximum energy that can be extracted from the wind.

Published material from recently commissioned international wind farms such as Horns Rev have demonstrated that wind farms can be designed and operated to provide a "balancing" service to the transmission operator. Discussions over the last year between National Grid and a cross section of European manufacturers indicate that the frequency response technology should currently be considered as developmental. However all the manufacturers have reasonable expectations of marketing a commercial product with a full frequency response capability early in 2004. Therefore developers placing orders for wind farms in 2004 for commissioning 12 to 18 months later should be able to provide full frequency response.

### Wind Farm Market Penetration

The first phase of off-shore wind farms comprising 18 sites are each limited to a maximum of 30 turbines by the dti and developers are choosing capacities between 60 and 99 MW. It is expected that these developments will not be required to have a generation licence, thereby relieving them from complying with the requirements of the Grid Code. The development programme published by the dti shows that the government is expecting these wind farms to start commissioning over 2004/2005. The total potential development is expected to be around 1.6 GW by 2006.

For the second phase of off-shore wind farms recent press releases from the government indicate that the dti has received applications for a total of 21 GW of off shore wind farm licences. The development programme published by the dti shows

that the government is expecting at least 4 GW of these wind farms to start commissioning in 2006.

The scale of this development should be considered in relation to the total system demand. Currently the typical overnight minimum summer demand is approximately 20 GW. In relation to this, it can be seen that wind farms have the potential to provide a large proportion of this generation. Given the clean nature of this generation it would seem illogical for it to be displaced with less environmentally friendly (fossil fuelled) generation in order to provide the necessary frequency control to enable NGC to continue to manage system frequency performance securely.

#### Proposed Requirements on Wind Farms

National Grid believes that it is reasonable to require the new generation technologies with completion dates after 1<sup>st</sup> January 2006 to provide a full frequency response capability. This view takes into account the following:

- the current state of wind farm technology and the lead times in project development
- the potential future market penetration of wind farms
- the need to maintain frequency control and system security in the future
- to minimise operation of less environmentally friendly generation
- to allow frequency response levels to be maintained independent of plant mix.

New generation technologies with commissioning before the 1<sup>st</sup> January 2006 will be required to be capable of limited frequency sensitive operation. Essentially this requires generators to be capable of reducing active power by at least 2 percent of output per 0.1Hz deviation of system frequency above 50.4 Hz. This can be delivered from wind farms either by controlling the power output from individual wind turbines or by reducing the number of wind turbines generating within the wind farm.

#### Discussion of frequency response delivery

National Grid understands that active power from a wind farm will vary with wind speed however this is not a bar to providing frequency response. In the figure below the top red line indicates the power that could potentially be exported by a wind farm extracting maximum power from the wind energy. The lower blue line indicates initial part loading of the wind farm and shows that when system frequency falls the power output from the wind farm rises to its theoretical maximum and falls again as system frequency recovers.

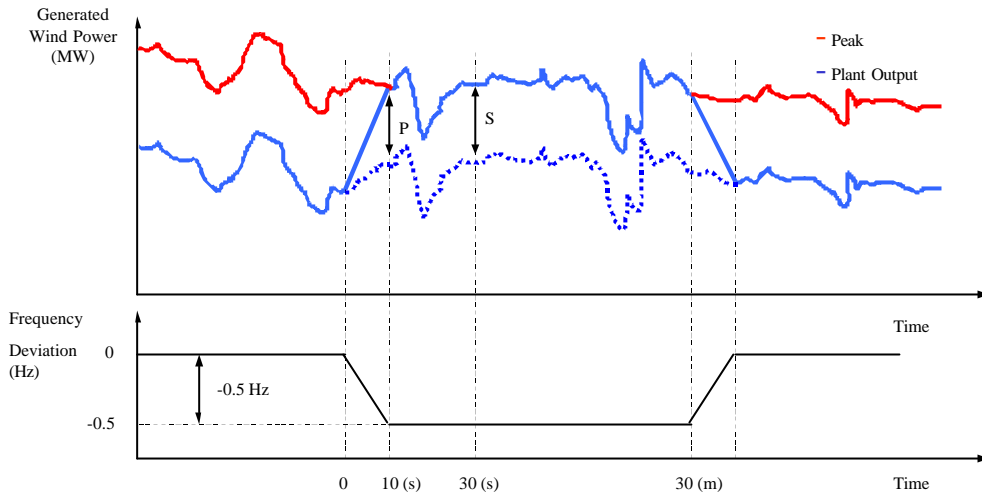

Assessment of the delivery of the frequency response service from a wind farm will require the variation in available energy at a site to be monitored in addition to active power output. From this data, the performance can be checked using an agreed power / wind speed curve for the site.

One area of discussion at the Working Group was the variability in wind speed within any individual site and the effect this would have on the holding of frequency response provision. This was raised from information tabled for a small five-turbine wind farm. While an issue if only one wind farm was providing response, National Grid would expect a number wind farms at geographically diverse locations to be providing frequency response to smooth out sudden losses in response due to local wind speed changes, maintaining an acceptable level of overall frequency control service. In addition, in the Balancing Market, the Generator would be submitting Maximum Export Limits and Physical Notifications for each half hour settlement period based on forecasts of wind speed giving some expectation of output level.

With self-dispatch under NETA, the output level is declared by the Generator. If National Grid requires plant to operate at a higher or lower level in order to provide frequency response, the change in output is instructed by accepting the bid or offer at the price declared by the generator. This market mechanism ensures that the economics of renewable energy production are reflected in the scheduling of frequency response.

### Appendix 6 – Fault Ride Through, Stability and Loss of Power Infeed

Under the NGC Security and Quality of Supply Standard referenced from the Transmission Licence, the National Grid Transmission System is designed, planned and operated so that the maximum loss of generation for a secured event will not exceed 1320MW. Should a loss of generation occur exceeding 1320MW, the fall in system frequency is likely to cause widespread customer demand disconnection by the national network low frequency defence plan.

Traditional “synchronous” generating units are inherently capable of continuing to operate through the transient voltage depression that accompanies any system fault event. Therefore a fault on a generating unit or it’s connections will not cause the loss of any other generating unit outside the fault clearance zone. The transmission system is designed and operated on this basis.

For clarity, the requirement to withstand faults on the transmission system has been added to the Grid Code. Without this ability there will either be a significant increase in the risk of customer disconnection spread across the whole country following a single fault, or there will be severe restrictions on the future concentrations of wind farm development in local areas.

This is illustrated by the figure below where the voltage across the system during a 3 phase fault applied at Cowley 400 kV substation is shown. It can be seen that all substations in England and Wales are temporarily exposed to levels of less than 90 % of nominal voltage. The area where transmission system voltages are depressed below 10% covers a large part of Oxfordshire despite the presence of a large synchronous generator connected to the adjacent substation.

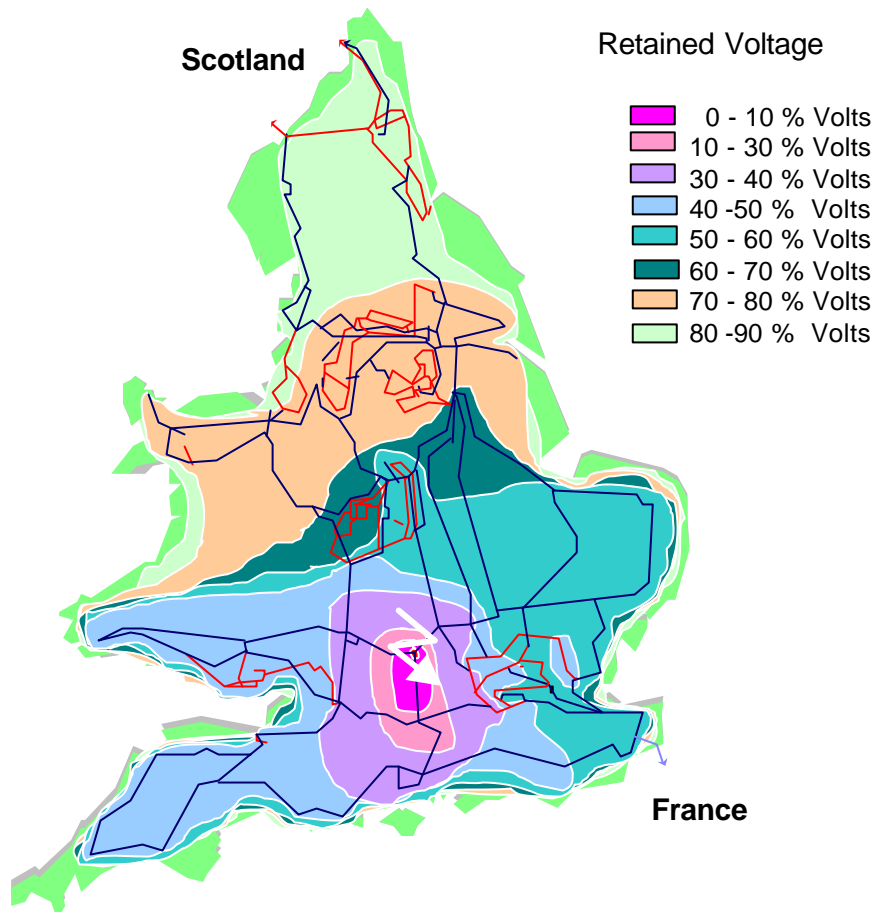

Some wind turbine technologies are reported to be susceptible to tripping even if the voltage transiently falls to levels as high as 70 %. The outcome of this would be significant volumes of generation would be lost. In this example all wind farms in the South of England and Wales would disconnect.

In order to relax and ease this requirement as far as practicable, fault ride-through capability is only required for faults on the 400/275 kV transmission system because of the wide propagation of the voltage disturbance. For faults at 132 kV and lower voltages the impedance of the supergrid transformers limits the severe transient voltage depression across the transmission network. However the voltage on the distribution system will be depressed. Current expectations are that it is unlikely that very large amounts of wind farm generation (exceeding 1320MW) can practically be connected within such a 132kV distribution group. From the transmission operators point of view, fault-ride through capability for distribution faults should not be an issue because the simultaneous loss of large amounts of centrally connected generation would be very unlikely to be beyond the credible loss limit of 1320 MW.

#### The Disconnection Option

As discussed, several wind farm technologies are reported to be susceptible to tripping in the event of a remote fault. The option of disconnecting wind farm generators during a fault condition and reconnecting after the fault was cleared has been considered. Whilst this might avoid a 'permanent' trip due to the fault, liaison with manufacturers and developers indicates that the duration of disconnection would be in the order of 5-10 seconds.

An analysis has been carried out into the impact of disconnecting wind farms following a fault coincident with a 1320MW generation loss and instantaneously reconnecting the wind farms at full power output. The table below shows the additional fall in transient frequency caused by wind farms disconnecting.

<b>Table showing additional frequency fall (Hz)</b>				
	<b>Wind Generation Disconnecting (MW)</b>			
<b>Wind Generation post fault disconnection time (s)</b>	<b>500</b>	<b>1000</b>	<b>2000</b>	<b>4000</b>
<b>2</b>	0.118	0.336	0.928	1.948
<b>5</b>	0.437	0.965	2.147	4.659

When considering the results in the table it should be noted that there is only a 0.2 Hz margin between the lowest frequency for a secured generation loss and (first stage) disconnection of 5% of total national demand. It can clearly be seen that even a temporary additional loss of wind farm output for a short duration will impact on customer security.

While the disconnection and reconnection option may be acceptable on large interconnected overseas networks where the impact on system frequency would be small, National Grid does not believe that this option is acceptable on the England and Wales system.

## **Appendix 7**

### **References to Documents on Requirements of Overseas Utilities**

Specifications for Connecting Wind Farms to the Transmission Network - Second Edition - Eltra - Transmission System Planning - 26 April 2000, Document Number 74557. (Denmark)

“E.ON Netz - Supplementary Grid Connection Rules for Wind Energy Plants - Supplementary Technical and Organisational Regulations for Connecting Wind Energy Converters to the Grid within the E.ON Netz Regulatory Zone. Dated - 01/12/2001” (Note we have three copies of this each being an unofficial translation from German to English) (German)

NEG Micon - Electrical Grid Requirements Dowec - NM 6000 - Document Number R090-JBZ-R0107. Jan Brozelie Dated 29/10/02 [Note that this is a comparison of European Grid Code Requirements and includes the Netherlands, Germany, Denmark, Scotland and England / Wales by NEG Micon.]

Estonian Requirements “Technical Requirements for Connecting Wind Turbine Installations to the Power Network - Reference EE 1042162 ST 7:2001”

## Appendix 8

### Grid Code Change Proposals

#### EXTRACTS FROM PREFACE (Not forming part of the Grid Code)

1. The operating procedures and principles governing **NGC's** relationship with all **Users** of the **NGC Transmission System**, be they **Generators**, **DC Converter Owners**, **Suppliers** or **Non-Embedded Customers** are set out in the **Grid Code**. The **Grid Code** specifies day-to-day procedures for both planning and operational purposes and covers both normal and exceptional circumstances.

.....

3. The **Grid Code** is divided into the following sections:-
  - (a) a **Planning Code** which provides generally for the supply of certain information by **Users** in order for **NGC** to undertake the planning and development of the **NGC Transmission System**;
  - (b) **Connection Conditions**, which specify the minimum technical, design and operational criteria which must be complied with by **NGC** at **Connection Sites** and by **Users** connected to or seeking connection with the **NGC Transmission System** or by **Generators** (other than in respect of **Small Power Stations**) or **DC Converter Owners** connected to or seeking connection to a **User's System**;

Extracts from Glossary and Definitions

Term	Definition
<b>Auxiliaries</b>	Any item of <b>Plant</b> and/or <b>Apparatus</b> not directly a part of the boiler plant or <b>Generating Unit</b> or <b>DC Converter</b> or <b>Power Park Module</b> , but required for the boiler plant's or <b>Generating Unit's</b> or <b>DC Converter's</b> or <b>Power Park Module's</b> functional operation.
<b>Control Centre</b>	A location used for the purpose of control and operation of the <b>NGC Transmission System</b> or a <b>User System</b> other than a <b>Generator's</b> or <b>DC Converter Station owner's System</b> or an <b>External System</b> .
<b>Control Point</b>	The point from which:-  A <b>Non-Embedded Customer's Plant</b> and <b>Apparatus</b> is controlled; or  A <b>BM Unit</b> , in England or Wales at a <b>Large Power Station</b> or at a <b>Medium Power Station</b> or with a <b>Demand Capacity</b> with a magnitude of 50MW or more, is physically controlled by a <b>BM Participant</b> ; or  In the case of any other <b>BM Unit</b> , data submission is co-ordinated for a <b>BM Participant</b> and instructions are received from <b>NGC</b> ,  as the case may be. For a <b>Generator</b> this will normally be at a <b>Power Station</b> and for a <b>DC Converter Station owner, the Control Point will be at a location agreed with NGC</b> . In the case of a <b>BM Unit</b> of an <b>Interconnector User</b> , the <b>Control Point</b> will be the <b>Control Centre</b> of the relevant <b>Externally Interconnected System Operator</b> .
<b>DC Converter</b>	<u>Any Apparatus with a Completion Date after 1 January 2004 used to convert alternating current electricity to direct current electricity, or vice-versa. A DC Converter is a standalone operative configuration at a single site comprising one or more converter bridges, together with one or more converter transformers, converter control equipment, essential protective and switching devices and auxiliaries, if any, use for conversion. In a bipolar arrangement, a DC Converter represents the bipolar configuration.</u>
<b>DC Converter Station</b>	<u>An installation comprising one or more DC Converters connecting a direct current interconnector to the NGC Transmission System; or, (if the installation has a rating of 50MW or more) to a User System, comprising part of an External Interconnection.</u>
<b>DC Network</b>	<u>All items of Plant and Apparatus connected together on the direct current side of a DC Converter.</u>
<b>Designed Minimum Operating Level</b>	The output (in whole MW) below which a <b>Genset</b> or a <b>DC Converter at a DC Converter Station (in any of its operating configurations)</b> has no <b>High Frequency Response</b> capability.
<b>De-Synchronise</b>	a) The act of taking a <b>Generating Unit, Power Park Module or DC Converter</b> off a <b>System</b> to which it has been <b>Synchronised</b> , by opening any connecting circuit breaker; or  b) The act of ceasing to consume electricity at an importing <b>BM Unit</b> ; and the term " <b>De-Synchronising</b> " shall be construed accordingly.
<b>External</b>	In relation to an <b>Externally Interconnected System Operator</b> means the transmission or distribution system which it owns or operates which

Term	Definition
<b>System</b>	is located outside England and Wales and any <b>Apparatus</b> or <b>Plant</b> which connects that system to the <b>External Interconnection</b> and which is owned or operated by such <b>Externally Interconnected System Operator</b> .
<b>Genset</b>	A <b>Generating Unit</b> , <b>Power Park Module</b> or <b>CCGT Module</b> at a <b>Large Power Station</b> .
<b>Generating Unit</b>	Unless otherwise provided in the <b>Grid Code</b> , any <b>Apparatus</b> which produces electricity, including, <del>for the avoidance of doubt, a <b>CCGT Unit</b></del> <b>a Synchronous Generating Unit and Non-synchronous Generating Unit</b> .
<b>Grid Entry Point</b>	A point at which a <b>Generating Unit</b> or a <b>CCGT Module</b> or a <b>CCGT Unit</b> <u>or a <b>DC Converter</b> or a <b>Power Park Module</b></u> , as the case may be, which is directly connected to the <b>NGC Transmission System</b> , connects to the <b>NGC Transmission System</b> .
<b>HV Generator Connections</b>	Apparatus connected at the same voltage as that of the <b>NGC Transmission System</b> , including Users' circuits, the higher voltage windings of Users' transformers and associated connection Apparatus.
<b>Import Usable</b>	<u>That portion of <b>Registered Import Capacity</b> which is not unavailable due to a <b>Planned Outage</b> or breakdown.</u>
<b>Intermittent Power Source</b>	<u>The primary source of power for a <b>Generating Unit</b> that can not be considered as controllable, e.g. wind, wave or solar.</u>
<b>Limited Frequency Sensitive Mode</b>	A mode whereby the operation of the <b>Genset</b> <u>(or <b>DC Converter</b> at a <b>DC Converter Station</b> exporting <b>Active Power</b> to the <b>Total System</b>)</u> is <b>Frequency</b> insensitive except when the <b>System Frequency</b> exceeds 50.4Hz, from which point <b>Limited High Frequency Response</b> must be provided.
<b>Limited High Frequency Response</b>	A response of a <b>Genset</b> <u>(or <b>DC Converter</b> at a <b>DC Converter Station</b> exporting <b>Active Power</b> to the <b>Total System</b>)</u> to an increase in <b>System Frequency</b> above 50.4Hz leading to a reduction in <b>Active Power</b> in accordance with the provisions of BC3.7.2.
<b>Minimum Generation</b>	The minimum output (in whole MW) which a <b>Genset</b> <u>or <b>DC Converter</b> at a <b>DC Converter Station</b></u> can generate <u>or export to the <b>Total System</b></u> under stable operating conditions, as registered with <b>NGC</b> under the <b>PC</b> (and amended pursuant to the <b>PC</b> ). For the avoidance of doubt, the output may go below this level as a result of operation in accordance with BC3.7.
<b>Minimum Import Capacity</b>	<u>The minimum input (in whole MW) into a <b>DC Converter</b> at a <b>DC Converter Station</b> (in any of its operating configurations) at the <b>Grid Entry Point</b> (or in the case of an <b>Embedded DC Converter</b> at the <b>User System Entry Point</b>) at which a <b>DC Converter</b> can operate in a stable manner, as registered with <b>NGC</b> under the <b>PC</b> (and amended pursuant to the <b>PC</b>).</u>
<b>Non-synchronous Generating Unit</b>	<u>A <b>Generating Unit</b> that is not a <b>Synchronous Generating Unit</b>.</u>
<b>Operational Intertripping</b>	The automatic tripping of circuit-breakers to prevent abnormal system conditions occurring, such as over voltage, overload, <b>System</b> instability, etc. after the tripping of other circuit-breakers following power <b>System</b> fault(s) which includes <b>System</b> to <b>Generating Unit</b> , <b>System</b> to <b>CCGT Module</b> , <b>System</b> to <b>Power Park Module</b> , <b>System</b> to <b>DC Converter</b> and <b>System</b> to <b>Demand</b> intertripping schemes.
<b>Power Park Module</b>	<u>A collection of <b>Non-synchronous Generating Units</b> (registered as a <b>Power Park Module</b> under the <b>PC</b>) that are powered by an <b>Intermittent</b></u>

Term	Definition
	<b>Power Source</b> , joined together by a <b>System</b> with a single electrical point of connection to the <b>NGC Transmission System (or User System if Embedded)</b> . The connection to the <b>NGC Transmission System (or User System if Embedded)</b> may include a <b>DC Converter</b> .
<b>Power Park Module Matrix</b>	The matrix described in Appendix 1 to BC1 under the heading <b>Power Park Module Matrix</b> .
<b>Power Park Module Planning Matrix</b>	A matrix in the form set out in Appendix 4 of OC2 showing the combination of <b>Power Park Units</b> within a <b>Power Park Module</b> which would be expected to be running under normal conditions.
<b>Power Park Unit</b>	A <b>Generating Unit</b> within a <b>Power Park Module</b> .
<b>Rated MW</b>	The "rating-plate" MW output of a <b>Generating Unit, Power Park Module or DC Converter</b> , being: (a) that output up to which the <b>Generating Unit</b> was designed to operate (Calculated as specified in <b>British Standard BS EN 60034 - 1: 1995</b> ); or (b) <u>the nominal rating for the MW output of a <b>Power Park Module</b> being the maximum continuous electric output power which the <b>Power Park Module</b> was designed to achieve under normal operating conditions; or</u> (c) <u>the nominal rating for the MW import capacity and export capacity (if at a <b>DC Converter Station</b>) of a <b>DC Converter</b>.</u>
<b>Registered Capacity</b>	<p>(a) In the case of a <b>Generating Unit</b> other than that forming part of a <b>CCGT Module or Power Park Module</b>, the normal full load capacity of a <b>Generating Unit</b> as declared by the <b>Generator</b>, less the MW consumed by the <b>Generating Unit</b> through the <b>Generating Unit's Unit Transformer</b> when producing the same (the resultant figure being expressed in whole MW).</p> <p>(b) In the case of a <b>CCGT Module or Power Park Module</b>, the normal full load capacity of <del>the</del> <b>CCGT Module or Power Park Module (as the case may be)</b> as declared by the <b>Generator</b>, being the <b>Active Power</b> declared by the <b>Generator</b> as being deliverable by the <b>CCGT Module or Power Park Module</b> at the <b>Grid Entry Point</b> (or in the case of an <b>Embedded CCGT Module or Power Park Module</b>, at the <b>User System Entry Point</b>), expressed in whole MW.</p> <p>(c) In the case of a <b>Power Station</b>, the maximum amount of <b>Active Power</b> deliverable by the <b>Power Station</b> at the <b>Grid Entry Point</b> (or in the case of an <b>Embedded Power Station</b> at the <b>User System Entry Point</b>), as declared by the <b>Generator</b>, expressed in whole MW. The maximum <b>Active Power</b> deliverable is the maximum amount deliverable simultaneously by the <b>Generating Units</b> and/or <b>CCGT Modules and/or Power Park Modules</b> less the MW consumed by the <b>Generating Units</b> and/or <b>CCGT Modules and/or Power Park Modules</b> in producing that <b>Active Power</b>.</p> <p><u>(d) In the case of a <b>DC Converter</b> at a <b>DC Converter Station</b>, the normal full load amount of <b>Active Power</b> transferable from a <b>DC Converter</b> at the <b>Grid Entry Point</b> (or in the case of an <b>Embedded DC Converter Station</b> at the <b>User System Entry Point</b>), as declared by the <b>DC Converter Station</b> owner, expressed in whole MW.</u></p> <p><u>(e) In the case of a <b>DC Converter Station</b>, the maximum amount of <b>Active Power</b> transferable from a <b>DC Converter Station</b> at the <b>Grid Entry Point</b> (or in the case of an <b>Embedded DC Converter</b></u></p>

Term	Definition
	<p><u>Station at the User System Entry Point</u>), as declared by the <b>DC Converter Station</b> owner, expressed in whole <b>MW</b>.</p>
<p><b>Registered Import Capability</b></p>	<p>In the case of a <b>DC Converter Station</b> containing <b>DC Converters</b> connected to an external system, the maximum amount of <b>Active Power</b> transferable into a <b>DC Converter Station</b> at the <b>Grid Entry Point</b> (or in the case of an <b>Embedded DC Converter Station</b> at the <b>User System Entry Point</b>), as declared by the <b>DC Converter Station</b> owner, expressed in whole <b>MW</b>.</p> <p>In the case of a <b>DC Converter</b> in a <b>DC Converter Station</b>, the normal full load amount of <b>Active Power</b> transferable into a <b>DC Converter</b> at the <b>Grid Entry Point</b> (or in the case of an <b>Embedded DC Converter Station</b> at the <b>User System Entry Point</b>), as declared by the <b>DC Converter</b> owner, expressed in whole <b>MW</b>.</p>
<p><b>Station Transformer</b></p>	<p>A transformer supplying electrical power to the <b>Auxiliaries</b> of:</p> <ul style="list-style-type: none"> <li>● a <b>Power Station</b>, which is not directly connected to the <b>Generating Unit</b> terminals (typical voltage ratios being 132/11kV or 275/11kV), or</li> <li>● a <b>DC Converter Station</b>.</li> </ul>
<p><b>Synchronised</b></p>	<p>a) The condition where an incoming <b>Generating Unit</b>, <b>Power Park Module</b>, <b>DC Converter</b> or <b>System</b> is connected to the busbars of another <b>System</b> so that the <b>Frequencies</b> and phase relationships of that <b>Generating Unit</b>, <b>Power Park Module</b>, <b>DC Converter</b> or <b>System</b>, as the case may be, and the <b>System</b> to which it is connected are identical, like terms shall be construed accordingly.</p> <p>b) The condition where an importing <b>BM Unit</b> is consuming electricity.</p>
<p><b>Synchronous Generating Unit</b></p>	<p><u>A <b>Generating Unit</b> which operates in synchronism with the <b>System</b>, including, for the avoidance of doubt, a <b>CCGT Unit</b></u></p>
<p><b>System Constrained Capacity</b></p>	<p>That portion of <b>Registered Capacity</b> or <b>Registered Import Capacity</b> not available due to a <b>System Constraint</b>.</p>
<p><b>User System Entry Point</b></p>	<p>A point at which a <b>Generating Unit</b>, a <b>CCGT Module</b>, a <b>CCGT Unit</b>, <u>a <b>Power Park Module</b> or a <b>DC Converter</b></u>, as the case may be, which is <b>Embedded</b> connects to the <b>User System</b>.</p>

## Extracts From The Planning Code

.....

### PC.3 SCOPE

PC.3.1 The **PC** applies to **NGC** and to **Users**, which in the **PC** means:

- (a) **Generators;**
- (b) **Network Operators; and**
- (c) **Non-Embedded Customers; and**
- (d) **DC Converter Station owners.**

The above categories of **User** will become bound by the **PC** prior to them generating, supplying ~~or~~ consuming or importing/exporting, as the case may be, and references to the various categories (or to the general category) of **User** should, therefore, be taken as referring to them in that prospective role as well as to **Users** actually connected.

PC.3.2 In the case of **Embedded Power Stations and Embedded DC Converters**, unless provided otherwise, the following provisions apply with regard to the provision of data under this **PC**:

- (a) each **Generator** shall provide the data direct to **NGC** in respect of **Embedded Large Power Stations** and **Embedded Medium Power Stations**;
- ~~(b)~~ each **DC Converter** owner shall provide the data direct to **NGC** in respect of **Embedded DC Converter Stations**;
- ~~(bc)~~ although data is not normally required specifically on **Embedded Small Power Stations** or on Embedded installations of direct current converters which do not form a DC Converter Station under this **PC**, each **Network Operator** in whose **System** they are **Embedded** should provide the data (contained in the Appendix) to **NGC** in respect of **Embedded Small Power Stations** or Embedded installations of direct current converters which do not form a DC Converter Station if:
  - (i) it falls to be supplied pursuant to the application for a **CUSC Contract** or in the **Statement of Readiness** to be supplied in connection with a **Bilateral Agreement** and/or **Construction Agreement**, by the **Network Operator**; or
  - (ii) it is specifically requested by **NGC** in the circumstances provided for under this **PC**.

PC.3.3 Certain data does not normally need to be provided in respect of certain **Embedded Power Stations** or **Embedded DC Converter Stations**, as provided in PC.A.1.12.

PC.4 PLANNING PROCEDURES

PC.4.1 Pursuant to Supplementary Standard Condition C7G of the **Transmission Licence**, the means by which **Users** and proposed **Users** of the **NGC Transmission System** are able to assess opportunities for connecting to, and using, the **NGC Transmission System** comprise two distinct parts, namely:

- (a) a statement, prepared by **NGC** under the **Transmission Licence**, showing for each of the seven succeeding **NGC Financial Years**, the opportunities available for connecting to and using the **NGC Transmission System** and indicating those parts of the **NGC Transmission System** most suited to new connections and transport of further quantities of electricity (the "**Seven Year Statement**"); and
- (b) an offer, in accordance with the **Transmission Licence**, by **NGC** to enter into a **CUSC Contract** for connection to (or, in the case of **Embedded Large Power Stations** and **Embedded Medium Power Stations** and **Embedded DC Converter Stations**, use of) the **NGC Transmission System**. A **Bilateral Agreement** is to be entered into for every **Connection Site** (and for certain **Embedded Power Stations** and for **Embedded DC Converter Stations**, as explained above) within the first two of the following categories and the existing **Bilateral Agreement** may be required to be varied in the case of the third category:
  - (i) existing **Connection Sites** (and for certain **Embedded Power Stations**, as detailed above) as at the **Transfer Date**;
  - (ii) new **Connection Sites** (and for certain **Embedded Power Stations**, and for **Embedded DC Converter Stations** as detailed above) with effect from the **Transfer Date**;
  - (iii) a **Modification** at a **Connection Site** (or in relation to the connection of certain **Embedded Power Stations** and for **Embedded DC Converter Stations**, as detailed above) (whether such **Connection Site** or connection exist on the **Transfer Date** or are new thereafter) with effect from the **Transfer Date**.

In this **PC**, unless the context otherwise requires, "connection" means any of these 3 categories.

.....

PC.4.2.4 Clearly, an existing **User** proposing a new **Connection Site** (or **Embedded Power Station** or **Embedded DC Converter Station** in the circumstances outlined in PC.4.1) will need to supply data both in an application for a **Bilateral Agreement** and under the **PC** in relation to that proposed new **Connection Site** (or **Embedded Power Station** or **Embedded DC Converter Station** in the circumstances outlined in PC.4.1) and that will be treated as **Preliminary Project Planning Data** or **Committed Project Planning Data** (as the case may be), but the data it supplies under the **PC** relating to its existing **Connection Sites** will be treated as **Connected Planning Data**.

.....

PC.4.3.1 Seven Year Statement

To enable the **Seven Year Statement** to be prepared, each **User** is required to submit to **NGC** (subject to the provisions relating to **Embedded Power Stations** and **Embedded DC Converter Stations** in PC.3.2) both the **Standard Planning Data** and the **Detailed Planning Data** as listed in parts I and 2 of the Appendix. This data should be submitted in calendar week 24 of each year (although **Network Operators** may delay the submission until calendar week 28) and should cover each of the seven succeeding **NGC Financial Years** (and in certain instances, the current year). Where, from the date of one submission to another, there is no change in the data (or in some of the data) to be submitted, instead of re-submitting the data, a **User** may submit a written statement that there has been no change from the data (or in some of the data) submitted the previous time.

.....

Submissions by Users

PC.A.1.2 (b) Where there is any change (or anticipated change) in **Committed Project Planning Data** or a significant change in **Connected Planning Data** in the category of **Forecast Data** or any change (or anticipated change) in **Connected Planning Data** in the categories of **Registered Data** or **Estimated Registered Data** supplied to **NGC** under the **PC**, notwithstanding that the change may subsequently be notified to **NGC** under the **PC** as part of the routine annual update of data (or that the change may be a **Modification** under the **CUSC**), the **User** shall, subject to PC.A.3.2.3 and PC.A.3.2.4 notify **NGC** in writing without delay.

.....

PC.A.1.2 (d) The routine annual update of data, referred to in (a)(iii) above, need not be submitted in respect of **Small Power Stations** or **Embedded installations of direct current converters which do not form a DC Converter Station** (except as provided in PC.3.2.(b)), or unless specifically requested by **NGC**, or unless otherwise specifically provided.

.....

PC.A.1.6 The following paragraphs in this Appendix relate to **Forecast Data**:

- 3.2.2(b), (h), (i) and (j)(part)
- 4.2.1
- 4.3.1
- 4.3.2
- 4.3.3
- 4.3.4
- 4.3.5
- 4.5(a)(ii) and (b)(ii)
- 4.7.1
- 5.2.1.
- 5.2.2

PC.A.1.7 The following paragraphs in this Appendix relate to **Registered Data** and **Estimated Registered Data**:

- 2.2.1
- 2.2.4
- 2.2.5
- 2.2.6
- 2.3.1
- 2.4.1
- 2.4.2
- 3.2.2(a), (c), (d), (e), (f), (g), (j) (part) and (k)
- 3.4.1
- 3.4.2
- 4.2.3
- 4.5(a)(i), (a)(iii), (b)(i) and (b)(iii)
- 4.6
- 5.3.2
- 5.4.2
- 5.4.3
- 5.4.5
- 6.2
- 6.3

.....

PC.A.1.12 Certain data does not need to be supplied in relation to **Embedded Power Stations** or **Embedded DC Converter Stations** where these are connected at a voltage level below the voltage level directly connected to the **NGC Transmission System** except in connection with a **CUSC Contract**, or unless specifically requested by **NGC**.

.....

PART 1

**STANDARD PLANNING DATA**

PC.A.2 **USER'S SYSTEM DATA**

- PC.A.2.1            Introduction
- PC.A.2.1.1        Each **User**, whether connected directly via an existing **Connection Point** to the **NGC Transmission System**, or seeking such a direct connection, shall provide **NGC** with data on its **User System** which relates to the **Connection Site** and/or which may have a system effect on the performance of the **NGC Transmission System**. Such data, current and forecast, is specified in PC.A.2.2 to PC.A.2.5. In addition each **Generator** with **Embedded Large Power Stations** or **Embedded Medium Power Stations** connected to the **Subtransmission System**, shall provide **NGC** with fault infeed data as specified in PC.A.2.5.5, and each **DC Converter** owner with **Embedded DC Converter Stations** connected to the **Subtransmission System** shall provide **NGC** with fault infeed data as specified in PC.A.2.5.6.
- PC.A.2.1.2        Each **User** must reflect the system effect at the **Connection Site(s)** of any third party **Embedded** within its **User System** whether existing or proposed.
- PC.A.2.1.3        Although not itemised here, each **User** with an existing or proposed **Embedded Small Power Station** or **Medium Power Station** or **Embedded DC Converter Station** with a **Registered Capacity** of less than 100MW or an **Embedded** installation of direct current converters which does not form a **DC Converter Station** in its **User System** may, at **NGC's** reasonable discretion, be required to provide additional details relating to the **User's System** between the **Connection Site** and the existing or proposed **Embedded Small Power Station** or **Medium Power Station** or **Embedded DC Converter Station** or **Embedded** installation of direct current converters which does not form a **DC Converter Station**.
- PC.A.2.1.4        At **NGC's** reasonable request, additional data on the **User's System** will need to be supplied. Some of the possible reasons for such a request, and the data required, are given in PC.A.6.2, PC.A.6.4, PC.A.6.5 and PC.A.6.6.
- PC.A.2.2            **User's System** Layout
- PC.A.2.2.1        Each **User** shall provide a **Single Line Diagram**, depicting both its existing and proposed arrangement(s) of load current carrying **Apparatus** relating to both existing and proposed **Connection Points**.
- PC.A.2.2.2        The **Single Line Diagram** (~~two~~ three examples are shown in Appendix B) must include all parts of the **User System** operating at **Supergrid Voltage**, and those parts of its **Subtransmission System** at any **NGC Site**. In addition, the **Single Line Diagram** must include all parts of the **User's Subtransmission System** operating at a voltage greater than 50kV which, under either intact network or **Planned Outage** conditions:-

- (a) normally interconnects separate **Connection Points**, or busbars at a **Connection Point** which are normally run in separate sections; or
- (b) connects **Embedded Large Power Stations**, or **Embedded Medium Power Stations**, or **Embedded DC Converter Stations** connected to the **User's Subtransmission System**, to a **Connection Point**.

At the **User's** discretion, the **Single Line Diagram** can also contain additional details of the **User's Subtransmission System** not already included above, and also details of the transformers connecting the **User's Subtransmission System** to a lower voltage. With **NGC's** agreement, the **Single Line Diagram** can also contain information about the **User's System** at a voltage below the voltage of the **Subtransmission System**.

The **Single Line Diagram** for a **Power Park Module** must include all parts of the System connecting generating equipment to the Grid Entry Point or (User System Entry Point if Embedded). As an alternative the **User** may choose to submit a **Single Line Diagram** of an electrically equivalent system connecting generating equipment to the **Grid Entry Point** (or **User System Entry Point** if **Embedded**). An example of a **Single Line Diagram** for a **Power Park Module** electrically equivalent system is shown in Appendix **B**.

The **Single Line Diagram** must include the points at which **Demand** data (provided under PC.A.4.3.4) and fault infeed data (provided under PC.A.2.5) are supplied.

PC.A.2.2.3

The above mentioned **Single Line Diagram** shall include:

- (a) electrical circuitry (ie. overhead lines, identifying which circuits are on the same towers, underground cables, power transformers, reactive compensation equipment and similar equipment); and
- (b) substation names (in full or abbreviated form) with operating voltages.

In addition, for all load current carrying **Apparatus** operating at **Supergrid Voltage**, the **Single Line Diagram** shall include:-

- (a) circuit breakers
- (b) phasing arrangements.

PC.A.2.2.3.1

For the avoidance of doubt, the **Single Line Diagram** to be supplied is in addition to the **Operation Diagram** supplied pursuant to CC.7.4.

PC.A.2.2.4

For each circuit shown on the **Single Line Diagram** provided under PC.A.2.2.1, each **User** shall provide the following details relating to that part of its **User System**:

Circuit Parameters:

Rated voltage (kV)  
Operating voltage (kV)  
Positive phase sequence reactance  
Positive phase sequence resistance  
Positive phase sequence susceptance  
Zero phase sequence reactance (both self and mutual)  
Zero phase sequence resistance (both self and mutual)  
Zero phase sequence susceptance (both self and mutual)

In the case of a **Single line Diagram** for a **Power Park Module** electrically equivalent system the data should be on a 100MVA base. Depending on the equivalent system supplied an equivalent tap changer range may need to be supplied. Similarly mutual values, rated voltage and operating voltage may be inappropriate.

PC.A.2.2.5 For each transformer shown on the **Single Line Diagram** provided under PC.A.2.2.1, each **User** shall provide the following details:

Rated MVA  
Voltage Ratio  
Winding arrangement  
Positive sequence reactance  
(max, min and nominal tap)  
Positive sequence resistance  
(max, min and nominal tap)  
Zero sequence reactance

PC.A.2.2.5.1. In addition, for all interconnecting transformers between the **User's Supergrid Voltage System** and the **User's Subtransmission System** the **User** shall supply the following information:-

Tap changer range  
Tap change step size  
Tap changer type: on load or off circuit  
Earthing method: Direct, resistance or reactance  
Impedance (if not directly earthed )

PC.A.2.2.6 Each **User** shall supply the following information about the **User's** equipment installed at a **Connection Site** which is owned, operated or managed by **NGC**:-

(a) Switchgear. For all circuit breakers:-

Rated voltage (kV)  
Operating voltage (kV)  
Rated 3-phase rms short-circuit breaking current, (kA)  
Rated 1-phase rms short-circuit breaking current, (kA)  
Rated 3-phase peak short-circuit making current, (kA)  
Rated 1-phase peak short-circuit making current, (kA)  
Rated rms continuous current (A)  
DC time constant applied at testing of asymmetrical breaking abilities (secs)

- (b) Substation Infrastructure. For the substation infrastructure (including, but not limited to, switch disconnectors, disconnectors, current transformers, line traps, busbars, through bushings, etc):-

Rated 3-phase rms short-circuit withstand current (kA)  
Rated 1-phase rms short-circuit withstand current (kA).  
Rated 3-phase short-circuit peak withstand current (kA)  
Rated 1- phase short-circuit peak withstand current (kA)  
Rated duration of short circuit withstand (secs)  
Rated rms continuous current (A)

A single value for the entire substation may be supplied, provided it represents the most restrictive item of current carrying apparatus.

PC.A.2.3 Lumped System Susceptance

PC.A.2.3.1 For all parts of the **User's Subtransmission System** which are not included in the **Single Line Diagram** provided under PC.A.2.2.1, each **User** shall provide the equivalent lumped shunt susceptance at nominal **Frequency**.

PC.A.2.3.1.1 This should include shunt reactors connected to cables which are not normally in or out of service independent of the cable (ie. they are regarded as part of the cable).

PC.A.2.3.1.2 This should not include:

- (a) independently switched reactive compensation equipment connected to the **User's System** specified under PC.A.2.4, or;
- (b) any susceptance of the **User's System** inherent in the **Demand (Reactive Power)** data specified under PC.A.4.3.1.

PC.A.2.4 Reactive Compensation Equipment

PC.A.2.4.1 For all independently switched reactive compensation equipment, including that shown on the **Single Line Diagram**, not owned by **NGC** and connected to the **User's System** at 132kV and above, other than power factor correction equipment associated directly with **Customers' Plant** and **Apparatus**, the following information is required:

- (a) type of equipment (eg. fixed or variable);
- (b) capacitive and/or inductive rating or its operating range in Mvar;
- (c) details of any automatic control logic to enable operating characteristics to be determined;

- (d) the point of connection to the **User's System** in terms of electrical location and **System** voltage.

PC.A.2.4.2 **DC Converter Station** owners are also required to provide information about the reactive compensation and harmonic filtering equipment required to ensure that their **Plant and Apparatus** complies with the criteria set out in CC.6.1.5.

PC.A.2.5 **Short Circuit Contribution to NGC Transmission System**

PC.A.2.5.1 **General**

- (a) To allow **NGC** to calculate fault currents, each **User** is required to provide data, calculated in accordance with **Good Industry Practice**, as set out in the following paragraphs of PC.A.2.5.
- (b) The data should be provided for the **User's System** with all **Generating Units, Power Park Units and DC Converters Synchronised** to that **User's System**. The **User** must ensure that the pre-fault network conditions reflect a credible **System** operating arrangement.
- (c) The list of data items required, in whole or part, under the following provisions, is set out in PC.A.2.5.6. Each of the relevant following provisions identifies which data items in the list are required for the situation with which that provision deals.

The fault currents in sub-paragraphs (a) and (b) of the data list in PC.A.2.5.6 should be based on an a.c. load flow that takes into account any pre-fault current flow across the **Point of Connection** being considered.

Measurements made under appropriate **System** conditions may be used by the **User** to obtain the relevant data.

- (d) **NGC** may at any time, in writing, specifically request for data to be provided for an alternative **System** condition, for example minimum plant, and the **User** will, insofar as such request is reasonable, provide the information as soon as reasonably practicable following the request.

PC.A.2.5.2 **Network Operators** and **Non-Embedded Customers** are required to submit data in accordance with PC.A.2.5.4. **Generators and DC Converter Station owners** are required to submit data in accordance with PC.A.2.5.5.

PC.A.2.5.3 Where prospective short-circuit currents on equipment owned, operated or managed by **NGC** are close to the equipment rating, and in **NGC's** reasonable opinion more accurate calculations of

the prospective short circuit currents are required, then **NGC** will request additional data as outlined in PC.A.6.6 below.

PC.A.2.5.4 **Data from Network Operators and Non-Embedded Customers**

Data is required to be provided at each node on the **Single Line Diagram** provided under PC.A.2.2.1 at which motor loads and/or **Embedded Small Power Stations** and/or **Embedded Medium Power Stations** and/or **Embedded installations of direct current converters which do not form a DC Converter Station** are connected, assuming a fault at that location, as follows:-

The data items listed under the following parts of PC.A.2.5.6:-

- (a) (i), (ii), (iii), (iv), (v) and (vi);

and the data items shall be provided in accordance with the detailed provisions of PC.A.2.5.6(c) - (f).

PC.A.2.5.5 **Data from Generators and DC Converter Station owners**

PC.A.2.5.5.1 For each **Generating Unit** with one or more associated **Unit Transformers**, the **Generator** is required to provide values for the contribution of the **Power Station Auxiliaries** (including **Auxiliary Gas Turbines** or **Auxiliary Diesel Engines**) to the fault current flowing through the **Unit Transformer(s)**.

The data items listed under the following parts of PC.A.2.5.6(a) should be provided:-

- (i), (ii) and (v);
- (iii) if the associated **Generating Unit** step-up transformer can supply zero phase sequence current from the **Generating Unit** side to the **NGC Transmission System**;
- (iv) if the value is not 1.0 p.u;

and the data items shall be provided in accordance with the detailed provisions of PC.A.2.5.6(c) - (f), and with the following parts of this PC.A.2.5.5.

PC.A.2.5.5.2 Auxiliary motor short circuit current contribution and any **Auxiliary Gas Turbine Unit** contribution through the **Unit Transformers** must be represented as a combined short circuit current contribution at the **Generating Unit's** terminals, assuming a fault at that location.

PC.A.2.5.5.3 If the **Power Station** or **DC Converter Station** has separate **Station Transformers**, data should be provided for the fault current contribution from each transformer at its high voltage terminals, assuming a fault at that location, as follows:-

The data items listed under the following parts of PC.A.2.5.6

- (a) (i), (ii), (iii), (iv), (v) and (vi);

and the data items shall be provided in accordance with the detailed provisions of PC.A.2.5.6(b) - (f).

PC.A.2.5.5.4 Data for the fault infeeds through both **Unit Transformers** and **Station Transformers** shall be provided for the normal running arrangement when the maximum number of **Gensets Generating Units** are **Synchronised** to the **System** or when all the **DC Converters at a DC Converter Station** are transferring rated MW in either direction. Where there is an alternative running arrangement (or transfer in the case of a **DC Converter Station**) which can give a higher fault infeed through the **Station Transformers**, then a separate data submission representing this condition shall be made.

PC.A.2.5.5.5 Unless the normal operating arrangement within the **Power Station** is to have the **Station** and **Unit Boards** interconnected within the **Power Station**, no account should be taken of the interconnection between the **Station Board** and the **Unit Board**.

PC.A.2.5.5.6 **Auxiliary motor short circuit current contribution and any auxiliary DC Converter Station contribution through the Station Transformers must be represented as a combined short circuit current contribution through the Station Transformers.**

PC.A.2.5.6 Data Items

(a) The following is the list of data utilised in this part of the **PC**. It also contains rules on the data which generally apply:-

- (i) Root mean square of the symmetrical three-phase short circuit current infeed at the instant of fault, ( $I_1''$ );
- (ii) Root mean square of the symmetrical three-phase short circuit current after the subtransient fault current contribution has substantially decayed, ( $I_1'$ );
- (iii) the zero sequence source resistance and reactance values of the **User's System** as seen from the node on the **Single Line Diagram** provided under PC.A.2.2.1 (or **Station Transformer** high voltage terminals or

**Generating Unit** terminals or DC Converter terminals, as appropriate) consistent with the infeed described in PC.A.2.5.1.(b);

- (iv) root mean square of the pre-fault voltage at which the maximum fault currents were calculated;
  - (v) the positive sequence X/R ratio at the instant of fault;
  - (vi) the negative sequence resistance and reactance values of the **User's System** seen from the node on the **Single Line Diagram** provided under PC.A.2.2.1 (or **Station Transformer** high voltage terminals, or **Generating Unit** terminals, or DC Converter terminals if appropriate) if substantially different from the values of positive sequence resistance and reactance which would be derived from the data provided above.
- (b) In considering this data, unless the **User** notifies **NGC** accordingly at the time of data submission, **NGC** will assume that the time constant of decay of the subtransient fault current corresponding to the change from  $I''$  to  $I_1'$ , ( $T''$ ) is not significantly different from 40ms. If that assumption is not correct in relation to an item of data, the **User** must inform **NGC** at the time of submission of the data.
- (c) The value for the X/R ratio must reflect the rate of decay of the d.c. component that may be present in the fault current and hence that of the sources of the initial fault current. All shunt elements and loads must therefore be deleted from any system model before the X/R ratio is calculated.
- (d) In producing the data, the **User** may use "time step analysis" or "fixed-point-in-time analysis" with different impedances.
- (e) If a fixed-point-in-time analysis with different impedances method is used, then in relation to the data submitted under (a) (i) above, the data will be required for "time zero" to give  $I_1''$ . The figure of 120ms is consistent with a decay time constant  $T''$  of 40ms, and if that figure is different, then the figure of 120ms must be changed accordingly.

- (f) Where a "time step analysis" is carried out, the X/R ratio may be calculated directly from the rate of decay of the d.c. component. The X/R ratio is not that given by the phase angle of the fault current if this is based on a system calculation with shunt loads, but from the Thévenin equivalent of the system impedance at the instant of fault with all non-source shunts removed.

PC.A.3 **GENERATING UNIT AND DC CONVERTER DATA**

PC.A.3.1 Introduction

Directly Connected

- PC.A.3.1.1 Each **Generator and DC Converter Station owner** with an existing, or proposed, **Power Station or DC Converter Station** directly connected, or to be directly connected, to the **NGC Transmission System**, shall provide **NGC** with data relating to that **Power Station or DC Converter Station**, both current and forecast, as specified in PC.A.3.2 to PC.A.3.4.

Embedded

- PC.A.3.1.2 (a) Each **Generator and DC Converter Station owner** with an existing, or proposed, **Embedded Large Power Station** and/or an **Embedded Medium Power Station and/or Embedded DC Converter Station** connected to the **Sub Transmission System**, shall provide **NGC** with data relating to that **Power Station**, both current and forecast, as specified in PC.A.3.2 to PC.A.3.4.
- (b) No data need be supplied in relation to any **Small Power Station** or any **Medium Power Station or installations of direct current converters which does not form a DC Converter Station**, connected at a voltage level below the voltage level of the **Subtransmission System** except:-
- (i) in connection with an application for, or under, a **CUSC Contract**, or
- (ii) unless specifically requested by **NGC** under PC.A.3.1.4.
- PC.A.3.1.3 (a) Each **Network Operator** shall provide **NGC** with the data specified in PC.A.3.2.2(c).
- (b) **Network Operators** need not submit planning data in respect of an **Embedded Small Power Station** unless required to do so under PC.A.1.2(b) or unless specifically requested under PC.A.3.1.4 below, in which case they will supply such data.

- PC.A.3.1.4 (a) PC.A.4.2.3(b) and PC.A.4.3.2(a) explain that the forecast **Demand** submitted by each **Network Operator** must be net of the output of all **Small Power Stations** and **Medium Power Stations** and **Customer Generating Plant** and all installations of direct current converters which do not form a DC Converter Station Embedded in that **Network Operator's System**. The **Network Operator** must inform **NGC** of the number of such **Embedded Power Stations** and such Embedded installations of direct current converters (including the number of **Generating Units** or Power Park Modules or DC Converters) together with their summated capacity.
- (b) On receipt of this data, the **Network Operator** or **Generator** (if the data relates to **Power Stations** referred to in PC.A.3.1.2) may be further required, at **NGC's** reasonable discretion, to provide details of **Embedded Small Power Stations** and **Embedded Medium Power Stations** and **Customer Generating Plant** and Embedded installations of direct current converters which do not form a DC Converter Station, both current and forecast, as specified in PC.A.3.2 to PC.A.3.4. Such requirement would arise where **NGC** reasonably considers that the collective effect of a number of such **Embedded Power Stations** and **Customer Generating Plants** and Embedded installations of direct current converters may have a significant system effect on the **NGC Transmission System**.
- PC.A.3.1.5 Where **Generating Units**, which term includes **CCGT Units**, Power Park Modules and DC Converters are connected to the **NGC Transmission System** via a busbar arrangement which is or is expected to be operated in separate sections, the section of busbar to which each **Generating Unit**, DC Converter or Power Park Module is connected is to be identified in the submission.
- PC.A.3.2 Output Data
- PC.A.3.2.1 (a) Large Power Stations
- Data items PC.A.3.2.2 (a), (b), (c), (d), (e), (f) and (h) are required with respect to each **Large Power Station** and each **Generating Unit** and Power Park Module of each **Large Power Station** (although (a) is not required for **CCGT Units** and (b), (d) and (e) are not normally required for **CCGT Units** and (a), (b), (c), (d), (e), (f) (g) and (h) are not required for Power Park Units).
- (b) Small Power Stations and Medium Power Stations
- Data item PC.A.3.2.2 (a) is required with respect to each **Small Power Station** and **Medium Power Station** and each **Generating Unit** and Power Park Module of each **Small Power Station** and **Medium Power Station** (although (a) is not required for **CCGT Units** or Power Park Units).

(c) **CCGT Units/Modules**

- (i) Data item PC.A.3.2.2 (g) is required with respect to each **CCGT Unit**;
- (ii) data item PC.A.3.2.2 (a) is required with respect to each **CCGT Module**; and
- (iii) data items PC.A.3.2.2 (b), (c), (d) and (e) are required with respect to each **CCGT Module** unless **NGC** informs the relevant **User** in advance of the submission that it needs the data items with respect to each **CCGT Unit** for particular studies, in which case it must be supplied on a **CCGT Unit** basis.

Where any definition utilised or referred to in relation to any of the data items does not reflect **CCGT Units**, such definition shall be deemed to relate to **CCGT Units** for the purposes of these data items. Any **Schedule** in the DRC which refers to these data items shall be interpreted to incorporate the **CCGT Unit** basis where appropriate;

**(d) Power Park Units/Modules**

Data items PC.A.3.2.2 (a), (b), (c), (d) (e) (f) (h) and (j) are required with respect to each **Power Park Module**

**(e) DC Converters**

Data items PC.A.3.2.2 (a), (b), (c), (d) (e) (f) (h) and (i) are required with respect to each **DC Converters** in a **DC Converter Stations**. For installations of direct current converters which do not form a **DC Converter Station** only data item PC.A.3.2.2.(a) is required.

PC.A.3.2.2

Items (a), (b), (d), (e), (f), (g) ~~and~~ (h) **(i) and (j)** are to be supplied by each **Generator, DC Converter Station owner** or **Network Operator** (as the case may be) in accordance with PC.A.3.1.1, PC.A.3.1.2, PC.A.3.1.3 and PC.A.3.1.4. Item (c) is to be supplied by each **Network Operator** in all cases:-

- (a) **Registered Capacity** (MW);
- (b) **Output Usable** (MW) on a monthly basis;
- (c) **System Constrained Capacity** (MW) ie. any constraint placed on the capacity of the **Embedded Generating Unit, Embedded Power Park Module, or DC Converter at an Embedded DC Converter Station** due to the **Network Operator's System** in which it is embedded. Where **Generating Units** (which term includes **CCGT**

Units), Power Park Modules or DC Converters are connected to a **Network Operator's User System** via a busbar arrangement which is or is expected to be operated in separate sections, details of busbar running arrangements and connected circuits at the substation to which the **Embedded Generating Unit, Embedded Power Park Module or Embedded DC Converter** is connected sufficient for **NGC** to determine where the **MW** generated by each **Generating Unit, Power Park Module or DC Converter** at that **Power Station or DC Converter Station** would appear onto the **NGC Transmission System**;

- (d) **Minimum Generation (MW)**;
- (e) **MW obtainable from Generating Units, Power Park Modules or DC Converters at a DC Converter Station in excess of Registered Capacity**;
- (f) **Generator Performance Chart**
  - (i) at the **Synchronous** **Generating Unit** stator terminals
  - (ii) at the electrical point of connection to the NGC Transmission System (or User System if Embedded) for a Non Synchronous Generating Unit (excluding a Power Park Unit), Power Park Module and DC Converter at a DC Converter Station;
- (g) a list of the **CCGT Units** within a **CCGT Module**, identifying each **CCGT Unit**, and the **CCGT Module** of which it forms part, unambiguously. In the case of a **Range CCGT Module**, details of the possible configurations should also be submitted, together:-
  - (i) (in the case of a **Range CCGT Module** connected to the **NGC Transmission System**) with details of the single **Grid Entry Point** (there can only be one) at which power is provided from the **Range CCGT Module**;
  - (ii) (in the case of an **Embedded Range CCGT Module**) with details of the single **User System Entry Point** (there can only be one) at which power is provided from the **Range CCGT Module**;

Provided that, nothing in this sub-paragraph (g) shall prevent the busbar at the relevant point being operated in separate sections;
- (h) expected running regime(s) at each **Power Station or DC Converter Station** and type of **Generating Unit**, eg. **Steam Unit, Gas Turbine Unit, Combined Cycle Gas Turbine Unit, Power Park Module, Novel Units** (specify by type), etc;

(i) The following additional items are only applicable to **DC Converters at DC Converter Stations.**

**Registered Import Capacity (MW);**

**Import Usable (MW) on a monthly basis;**

**Minimum Import Capacity (MW);**

MW that may be absorbed by a **DC Converter** in excess of **Registered Import Capacity** and the duration for which this is available;

(ii) the number and types of the **Power Park Units** within a **Power Park Module**, identifying each **Power Park Unit**, and the **Power Park Module** of which it forms part, unambiguously. In the case of a **Power Station** directly connected to the **NGC Transmission System** with multiple **Power Park Modules** where **Power Park Units** can be selected to run in different **Power Park Modules**, details of the possible configurations should also be submitted.

#### PC.A.3.2.3

Notwithstanding any other provision of this PC, the **CCGT Units** within a **CCGT Module**, details of which are required under paragraph (g) of PC.A.3.2.2, can only be amended in accordance with the following provisions:-

- (a) if the **CCGT Module** is a **Normal CCGT Module**, the **CCGT Units** within that **CCGT Module** can only be amended such that the **CCGT Module** comprises different **CCGT Units** if **NGC** gives its prior consent in writing. Notice of the wish to amend the **CCGT Units** within such a **CCGT Module** must be given at least 6 months before it is wished for the amendment to take effect;
- (b) if the **CCGT Module** is a **Range CCGT Module**, the **CCGT Units** within that **CCGT Module** and the **Grid Entry Point** at which the power is provided can only be amended as described in BC1.A1.6.4.

#### PC.A.3.2.4

Notwithstanding any other provision of this PC, the **Power Park Units** within a **Power Park Module**, details of which are required under paragraph (j) of PC.A.3.2.2, can only be amended in accordance with the following provisions:-

- (a) if the **Power Park Units** within that **Power Park Module** can only be amended such that the **Power Park Module** comprises different **Power Park Units** due to repair/replacement of individual **Power Park Units** if **NGC** gives its prior consent in writing. Notice of the wish to amend a **Power Park Unit** within such a **Power Park**

Module must be given at least 4 weeks before it is wished for the amendment to take effect;

- (b) if the **Power Park Units** within that **Power Park Module** can be selected to run in different **Power Park Modules** as an alternative operational running arrangement the **Power Park Units** within the **Power Park Module** and the **Grid Entry Point** at which the power is provided can only be amended as described in BC1.A1.7.4.

PC.A.3.3. Rated Parameters Data

PC.A.3.3.1 The following information is required to facilitate an early assessment, by **NGC**, of the need for more detailed studies;

- (a) for all **Generating Units** and **Power Park Modules**:
- Rated MVA;
  - Rated MW**;
  - Direct axis transient reactance;
  - Inertia constant, MWsecs/MVA (for whole machine);
- (b) for each **Synchronous** **Generating Unit**:
- Short circuit ratio;
  - Direct axis transient reactance;
  - ~~Inertia constant (for whole machine), MWsecs/MVA;~~
- (c) for each **Synchronous** **Generating Unit** step-up transformer:
- Rated MVA;
  - Positive sequence reactance (at max, min and nominal tap).
- (d) for each **DC Converter** at a **DC Converter Station** or **DC Converter** connecting a **Power Park Module**
- DC Converter type (e.g. current/voltage sourced)
  - Rated MW per pole
  - Number of poles and pole arrangement
  - Rated DC voltage/pole (kV)
  - Return Path Arrangement
  - Remote AC connection arrangement
- (e) for each type of **Power Park Unit** in a **Power Park Module** not connected to the **Total System** by a **DC Converter**
- Rated MVA
  - Inertia Constant (MWsec/MVA)
  - Stator Reactance.

Magnetising Reactance.  
Rotor Resistance.  
Rotor Reactance.  
Rotor Speed Range (Doubly Fed Induction only)  
Converter Rating (Doubly Fed Induction only)

This information should only be given in the data supplied with the application for a **CUSC Contract** (if appropriate for any variation), as the case may be.

PC.A.3.4 General **Generating Unit, Power Park Module and DC Converter** Data

PC.A.3.4.1 The point of connection to the **NGC Transmission System** or the **Total System**, if other than to the **NGC Transmission System**, in terms of geographical and electrical location and system voltage is also required.

PC.A.3.4.2 (a) Type of **Generating Unit** (ie **Synchronous Generating Unit, Non-synchronous Generating Unit, DC Converter or Power Park Module**).

(ab) In the case of a **Synchronous Generating Unit** details of the **Exciter** category, for example whether it is a rotating **Exciter** or a static **Exciter** or in the case of a **Non-synchronous Generating Unit** the voltage control system.

(bc) Whether a **Power System Stabiliser** is fitted.

PC.A.4 **DEMAND AND ACTIVE ENERGY DATA**

PC.A.4.1 Introduction

PC.A.4.1.1 Each **User** directly connected to the **NGC Transmission System** with **Demand** shall provide **NGC** with the **Demand** data, historic, current and forecast, as specified in PC.A.4.2, PC.A.4.3 and PC.A.4.5. Paragraphs PC.A.4.1.2 and PC.A.4.1.3 apply equally to **Active Energy** requirements as to **Demand** unless the context otherwise requires.

PC.A.4.1.2 Data will need to be supplied by:

(a) each **Network Operator**, in relation to **Demand** and **Active Energy** requirements on its **User System**;

(b) each **Non-Embedded Customer** (including **Pumped Storage Generators** with respect to Pumping **Demand**) in relation to its **Demand** and **Active Energy** requirements.

(c) each **DC Converter Station** owner, in relation to **Demand** and **Active Energy** transferred (imported) to its **DC Converter Station**.

**Demand of Power Stations** directly connected to the **NGC Transmission System** is to be supplied by the **Generator** under PC.A.5.2.

PC.A.4.1.3 References in this **PC** to data being supplied on a half hourly basis refer to it being supplied for each period of 30 minutes ending on the hour or half-hour in each hour.

PC.A.4.2 **Demand (Active Power) and Active Energy Data**

PC.A.4.2.1 Forecast daily **Demand (Active Power)** profiles, as specified in (a), (b) and (c) below, in respect of each of the **User's User Systems** (each summated over all **Grid Supply Points** in each **User System**) are required for:

- (a) peak day on each of the **User's User Systems** (as determined by the **User**) giving the numerical value of the maximum **Demand (Active Power)** that in the **Users'** opinion could reasonably be imposed on the **NGC Transmission System**;
- (b) day of peak **NGC Demand (Active Power)** as notified by **NGC** pursuant to PC.A.4.2.2;
- (c) day of minimum **NGC Demand (Active Power)** as notified by **NGC** pursuant to PC.A.4.2.2.

In addition, the total **Demand (Active Power)** in respect of the time of peak **NGC Demand** in the preceding **NGC Financial Year** in respect of each of the **User's User Systems** (each summated over all **Grid Supply Points** in each **User System**) both outturn and weather corrected shall be supplied.

PC.A.4.2.2 No later than calendar week 17 each year **NGC** shall notify each **Network Operator** and **Non-Embedded Customer** in writing of the following, for the current **NGC Financial Year** and for each of the following seven **NGC Financial Years**, which will, until replaced by the following year's notification, be regarded as the relevant specified days and times under PC.A.4.2.1:

- a) the date and time of the annual peak of the **NGC Demand**;
- b) the date and time of the annual minimum of the **NGC Demand**.

PC.A.4.2.3 The total **Active Energy** used on each of the **Network Operators'** or **Non-Embedded Customers' User Systems** (each summated over all **Grid Supply Points** in each **User System**) in the preceding **NGC Financial Year**, both outturn and weather corrected, together with a prediction for the current financial year,

is required. Each **Active Energy** submission shall be subdivided into the following categories of **Customer** tariff:

LV1  
LV2  
LV3  
HV  
EHV  
Traction  
Lighting

In addition, the total **User System** losses and the **Active Energy** provided by **Embedded Small Power Stations** and **Embedded Medium Power Stations** shall be supplied.

PC.A.4.2.4 All forecast **Demand (Active Power)** and **Active Energy** specified in PC.A.4.2.1 and PC.A.4.2.3 shall:

- (a) in the case of PC.A.4.2.1(a), (b) and (c), be such that the profiles comprise average **Active Power** levels in 'MW' for each time marked half hour throughout the day;
- (b) in the case of PC.A.4.2.1(a), (b) and (c), be that remaining after any deductions reasonably considered appropriate by the **User** to take account of the output profile of all **Embedded Small Power Stations** and **Embedded Medium Power Stations** and **Customer Generating Plant** and imports across **Embedded External Interconnections** including imports across Embedded installations of direct current converters which do not form a DC Converter Station and Embedded DC Converter Stations with a Registered Capacity of less than 100MW;
- (c) in the case of PC.A.4.2.1(a) and (b), be based on **Annual ACS Conditions** and in the case of PC.A.4.2.1(c) and the details of the annual **Active Energy** required under PC.A.4.2.3 be based on **Average Conditions**.

PC.A.4.3 **Connection Point Demand (Active and Reactive Power)**

PC.A.4.3.1 Forecast **Demand (Active Power)** and **Power Factor** (values of the **Power Factor** at maximum and minimum continuous excitation may be given instead where more than 95% of the total **Demand** at a **Connection Point** is taken by synchronous motors) to be met at each are required for:

- (a) the time of the maximum **Demand (Active Power)** at the **Connection Point** (as determined by the **User**) that in the **User's** opinion could reasonably be imposed on the **NGC Transmission System**;

- (b) the time of peak **NGC Demand** as provided by **NGC** under PC.A.4.2.2;
- (c) the time of minimum **NGC Demand** as provided by **NGC** under PC.A.4.2.2.

PC.A.4.3.2

All forecast **Demand** specified in PC.A.4.3.1 shall:

- (a) be that remaining after any deductions reasonably considered appropriate by the **User** to take account of the output of all **Embedded Small Power Stations** and **Embedded Medium Power Stations** and **Customer Generating Plant** and imports across **Embedded External Interconnections**, including **Embedded installations of direct current converters which do not form a DC Converter Station and Embedded DC Converter Stations** and such deductions should be separately stated;
- (b) include any **User's System** series reactive losses but exclude any reactive compensation equipment specified in PC.A.2.4 and exclude any network susceptance specified in PC.A.2.3;
- (c) in the case of PC.A.4.3.1(a) and (b) be based on **Annual ACS Conditions** and in the case of PC.A.4.3.1(c) be based on **Average Conditions**.

PC.A.4.3.3

Where two or more **Connection Points** normally run in parallel with the **NGC Transmission System** under intact network conditions, and a **Single Line Diagram** of the interconnection has been provided under PC.A.2.2.2, the **User** may provide a single submission covering the aggregate **Demand** for all such **Connection Points**.

PC.A.4.3.4

Each **Single Line Diagram** provided under PC.A.2.2.2 shall include the **Demand (Active Power)** and **Power Factor** (values of the **Power Factor** at maximum and minimum continuous excitation may be given instead where more than 95% of the **Demand** is taken by synchronous motors) at the time of the peak **NGC Demand** (as provided under PC.A.4.2.2) at each node on the **Single Line Diagram**. These **Demands** shall be consistent with those provided under PC.A.4.3.1(b) above for the relevant year.

PC.A.4.3.5

So that **NGC** is able to assess the impact on the **NGC Transmission System** of the diversified **NGC Demand** at various periods throughout the year, each **User** shall provide additional forecast **Demand** data as specified in PC.A.4.3.1 and PC.A.4.3.2 but with respect to times to be specified by **NGC**. However, **NGC** shall not make such a request for additional data more than once in any calendar year.

PC.A.4.4 **NGC** will assemble and derive in a reasonable manner, the forecast information supplied to it under PC.A.4.2.1, PC.A.4.3.1. and PC.A.4.3.4 above into a cohesive forecast and will use this in preparing **Forecast Demand** information in the **Seven Year Statement** and for use in **NGC's Operational Planning**. If any **User** believes that the cohesive forecast **Demand** information in the **Seven Year Statement** does not reflect its assumptions on **Demand**, it should contact **NGC** to explain its concerns and may require **NGC**, on reasonable request, to discuss these forecasts. In the absence of such expressions, **NGC** will assume that **Users** concur with **NGC's** cohesive forecast.

**Demand Transfer Capability**

PC.A.4.5 Where a **User's Demand** or group of **Demands (Active and Reactive Power)** may be offered by the **User** to be supplied from alternative **Connection Point(s)**, (either through non-**NGC** interconnections or through **Demand** transfer facilities) and the **User** reasonably considers it appropriate that this should be taken into account (by **NGC**) in designing the **Connection Site** the following information is required:

(a) **First Circuit (Fault) Outage Conditions**

- (i) the alternative **Connection Point(s)**;
- (ii) the **Demand (Active and Reactive Power)** which may be transferred under the loss of the most critical circuit from or to each alternative **Connection Point** (to the nearest 5MW/5Mvar);
- (iii) the arrangements (eg. manual or automatic) for transfer together with the time required to effect the transfer.

(b) **Second Circuit (Planned) Outage Conditions**

- (i) the alternative **Connection Point(s)**;
- (ii) the **Demand (Active and Reactive Power)** which may be transferred under the loss of the most critical circuit from or to each alternative **Connection Point** (to the nearest 5MW/5Mvar);
- (iii) the arrangements (eg. manual or automatic) for transfer together with the time required to effect the transfer.

PC.A.4.6 **Control of Demand or Reduction of Pumping Load Offered as Reserve**

- Magnitude of **Demand** or pumping load

which is tripped

M  
W

- **System Frequency** at which tripping is initiated Hz
- Time duration of **System Frequency** below trip setting for tripping to be initiated s
- Time delay from trip initiation to tripping s

PC.A.4.7 General Demand Data

PC.A.4.7.1 The following information is infrequently required and should be supplied (wherever possible) when requested by **NGC**:

- (a) details of any individual loads which have characteristics significantly different from the typical range of Domestic, Commercial or Industrial loads supplied;
- (b) the sensitivity of the **Demand (Active and Reactive Power)** to variations in voltage and **Frequency** on the **NGC Transmission System** at the time of the peak **Demand (Active Power)**. The sensitivity factors quoted for the **Demand (Reactive Power)** should relate to that given under PC.A.4.3.1 and, therefore, include any **User's System** series reactive losses but exclude any reactive compensation equipment specified in PC.A.2.4 and exclude any network susceptance specified in PC.A.2.3;
- (c) details of any traction loads, e.g. connection phase pairs and continuous load variation with time;
- (d) the average and maximum phase unbalance, in magnitude and phase angle, which the **User** would expect its **Demand** to impose on the **NGC Transmission System**;
- (e) the maximum harmonic content which the **User** would expect its **Demand** to impose on the **NGC Transmission System**;
- (f) details of all loads which may cause **Demand** fluctuations greater than those permitted under **Engineering Recommendation P28, Stage 1** at a **Point of Common Coupling** including the **Flicker Severity (Short Term)** and the **Flicker Severity (Long Term)**.

PART 2

DETAILED PLANNING DATA

PC.A.5 GENERATING UNIT, POWER PARK MODULE AND DC  
CONVERTER DATA

PC.A.5.1 Introduction

*Directly Connected*

PC.A.5.1.1 Each **Generator**, with existing or proposed **Power Stations** directly connected, or to be directly connected, to the **NGC Transmission System**, shall provide **NGC** with data relating to that **Plant** and **Apparatus**, both current and forecast, as specified in PC.A.5.2 and PC.A.5.3.

Embedded

PC.A.5.1.2 Each **Generator**, with existing or proposed **Embedded Large Power Stations** and **Embedded Medium Power Stations** shall provide **NGC** with data relating to each of those **Large Power Stations** and/or **Medium Power Stations**, both current and forecast, as specified in PC.A.5.2 and PC.A.5.3. However, no data need be supplied in relation to those **Embedded Medium Power Stations** if they are connected at a voltage level below the voltage level of the **Subtransmission System** except in connection with an application for, or under a, **CUSC Contract** or unless specifically requested by **NGC** under PC.A.5.1.4.

PC.A.5.1.3 Each **Network Operator** need not submit **Planning Data** in respect of **Embedded Small Power Stations** unless required to do so under PC.A.1.2(b) or unless specifically requested under PC.A.5.1.4 below, in which case they will supply such data.

PC.A.5.1.4 PC.A.4.2.3(b) and PC.A.4.3.2(a) explained that the forecast **Demand** submitted by each **Network Operator** must be net of the output of all **Medium Power Stations** and **Small Power Stations** and **Customer Generating Plant Embedded** in that **User's System**. In such cases (PC.A.3.1.4 also refers), the **Network Operator** must inform **NGC** of the number of such **Power Stations** (including the number of **Generating Units**) together with their summated capacity. On receipt of this data, the **Network Operator** or **Generator** (if the data relates to **Power Stations** referred to in PC.A.5.1.2) may be further required at **NGC's** discretion to provide details of **Embedded Small Power Stations** and **Embedded Medium Power Stations** and **Customer Generating Plant**, both current and forecast, as specified in PC.A.5.2 and PC.A.5.3. Such requirement would arise when **NGC** reasonably considers that the collective effect of a number of such **Embedded Small Power Stations** and **Embedded Medium Power Stations** and **Customer Generating Plants** may have a significant system effect on the **NGC Transmission System**.

- PC.A.5.2      **Demand**
- PC.A.5.2.1      For each **Generating Unit** which has an associated **Unit Transformer**, the value of the **Demand** supplied through this **Unit Transformer** when the **Generating Unit** is at **Rated MW** output is to be provided.
- PC.A.5.2.2      Where the **Power Station** has associated **Demand** additional to the unit-supplied **Demand** of PC.A.5.2.1 which is supplied from either the **NGC Transmission System** or the **Generator's User System** the **Generator** shall supply forecasts for each **Power Station** of:
- a)      the maximum **Demand** that, in the **User's** opinion, could reasonably be imposed on the **NGC Transmission System** or the **Generator's User System** as appropriate;
  - b)      the **Demand** at the time of the peak **NGC Demand**;
  - c)      the **Demand** at the time of minimum **NGC Demand**.
- PC.A.5.2.3      No later than calendar week 17 each year **NGC** shall notify each **Generator** with **Large Power Stations** and/or **Medium Power Stations** in writing of the following, for the current **NGC Financial Year** and for each of the following seven **NGC Financial Years**, which will be regarded as the relevant specified days and times under PC.A.5.2.2:
- a)      the date and time of the annual peak of the **NGC Demand** at **Annual ACS Conditions**;
  - b)      the date and time of the annual minimum of the **NGC Demand** at **Average Conditions**.
- PC.A.5.2.4      At its discretion, **NGC** may also request further details of the **Demand** as specified in PC.A.4.6
- PC.A.5.3      Synchronous **Generating Unit** and Associated Control System Data
- PC.A.5.3.1      The data submitted below are not intended to constrain any **Ancillary Services Agreement**
- PC.A.5.3.2      The following **Synchronous** **Generating Unit** and **Power Station** data should be supplied:
- (a)      **Synchronous Generating Unit Parameters**
    - Rated terminal volts (kV)
    - \* Rated MVA
    - \* **Rated MW**
    - \* Minimum Generation MW
    - \* Short circuit ratio
    - Direct axis synchronous reactance

- \* Direct axis transient reactance  
Direct axis sub-transient reactance  
Direct axis short-circuit transient time constant.  
Direct axis short-circuit sub-transient time constant.  
Quadrature axis synchronous reactance  
Quadrature axis sub-transient reactance  
Quadrature axis short-circuit sub-transient time constant.  
Stator time constant  
Stator leakage reactance  
Armature winding direct-current resistance.

**Note:** The above data item relating to armature winding direct-current resistance need only be supplied by **Generators** with respect to **Generating Units** commissioned after 1st March 1996 and in cases where, for whatever reason, the **Generator** is aware of the value of the relevant parameter.

- \* Turbogenerator inertia constant (MWsec/MVA)  
Rated field current (amps) at **Rated MW** and Mvar output and at rated terminal voltage.

Field current (amps) open circuit saturation curve for **Generating Unit** terminal voltages ranging from 50% to 120% of rated value in 10% steps as derived from appropriate manufacturers test certificates.

(b) Parameters for **Generating Unit** Step-up Transformers

- \* Rated MVA  
Voltage ratio
- \* Positive sequence reactance  
(at max, min, & nominal tap)  
Positive sequence resistance  
(at max, min, & nominal tap)  
Zero phase sequence reactance  
Tap changer range  
Tap changer step size  
Tap changer type: on load or off circuit

(c) Excitation Control System parameters

**Note:** The data items requested under Option 1 below may continue to be provided by **Generators** in relation to **Generating Units** on the **System** at 09 January 1995 (in this paragraph, the "relevant date") or they may provide the new data items set out under Option 2. **Generators** must supply the data as set out under Option 2 (and not those under Option 1) for **Generating Unit** excitation control systems commissioned after the relevant date, those **Generating Unit** excitation control systems recommissioned for any reason such as refurbishment after the relevant date and **Generating Unit** excitation control systems

where, as a result of testing or other process, the **Generator** is aware of the data items listed under Option 2 in relation to that **Generating Unit**.

Option 1

DC gain of **Excitation Loop**  
Rated field voltage  
Maximum field voltage  
Minimum field voltage  
Maximum rate of change of field voltage (rising)  
Maximum rate of change of field voltage (falling)  
Details of **Excitation Loop** described in block diagram form showing transfer functions of individual elements.  
Dynamic characteristics of **Over-excitation Limiter**.  
Dynamic characteristics of **Under-excitation Limiter**

Option 2

**Excitation System Nominal Response**  
**Rated Field Voltage**  
**No-Load Field Voltage**  
**Excitation System On-Load Positive Ceiling Voltage**  
**Excitation System No-Load Positive Ceiling Voltage**  
**Excitation System No-Load Negative Ceiling Voltage**

Details of **Excitation System** (including **PSS** if fitted) described in block diagram form showing transfer functions of individual elements.

Details of **Over-excitation Limiter** described in block diagram form showing transfer functions of individual elements.

Details of **Under-excitation Limiter** described in block diagram form showing transfer functions of individual elements.

(d) Governor Parameters

Incremental Droop values (in %) are required for each **Generating Unit** at six MW loading points (MLP1 to MLP6) as detailed in PC.A.5.4.1 (this data item needs only be provided for **Large Power Stations**)

**Note:** The data items requested under Option 1 below may continue to be provided by **Generators** in relation to **Generating Units** on the **System** at 09 January 1995 (in this paragraph, the "relevant date") or they may provide the new data items set out under Option 2. **Generators** must supply the data as set out under Option 2 (and not those under Option 1) for **Generating Unit** governor control systems commissioned after the relevant

date, those **Generating Unit** governor control systems recommissioned for any reason such as refurbishment after the relevant date and **Generating Unit** governor control systems where, as a result of testing or other process, the **Generator** is aware of the data items listed under Option 2 in relation to that **Generating Unit**.

Option 1

(i) Governor Parameters (for Reheat **Steam Units**)

HP governor average gain MW/Hz  
Speeder motor setting range  
HP governor valve time constant  
HP governor valve opening limits  
HP governor valve rate limits  
Reheater time constant (**Active Energy** stored in reheater)

IP governor average gain MW/Hz  
IP governor setting range  
IP governor valve time constant  
IP governor valve opening limits  
IP governor valve rate limits

Details of acceleration sensitive elements in HP & IP governor loop.  
A governor block diagram showing transfer functions of individual elements.

(ii) Governor Parameters (for Non-Reheat **Steam Units and Gas Turbine Units**)

Governor average gain  
Speeder motor setting range  
Time constant of steam or fuel governor valve  
Governor valve opening limits  
Governor valve rate limits  
Time constant of turbine  
Governor block diagram

The following data items need only be supplied for **Large Power Stations**:-

(iii) Boiler & Steam Turbine Data

Boiler Time Constant (Stored **Active Energy**)  
s  
HP turbine response ratio:  
proportion of **Primary Response**  
%  
arising from HP turbine.

HP turbine response ratio:  
proportion of **High Frequency Response** %  
arising from HP turbine.

[End of Option 1]

Option 2

(i) Governor and associated prime mover  
Parameters - All **Generating Units**

Governor Block Diagram showing transfer  
function of individual elements including  
acceleration sensitive elements.

Governor Time Constant (in seconds)

Speeder Motor Setting Range (%)

Average Gain (MW/Hz)

Governor Deadband (this data item need only  
be provided for **Large Power Stations**)

- Maximum Setting

±Hz

- Normal Setting

±Hz

- Minimum Setting

±Hz

Where the **Generating Unit** governor does not  
have a selectable deadband facility, then the  
actual value of the deadband need only be  
provided

(ii) Governor and associated prime mover  
Parameters - **Steam Units**

HP Valve Time Constant (in seconds)

HP Valve Opening Limits (%)

HP Valve Opening Rate Limits (%/second)

HP Valve Closing Rate Limits (%/second)

HP Turbine Time Constant (in seconds)

IP Valve Time Constant (in seconds)

IP Valve Opening Limits (%)

IP Valve Opening Rate Limits (%/second)

IP Valve Closing Rate Limits (%/second)

IP Turbine Time Constant (in seconds)

LP Valve Time Constant (in seconds)

LP Valve Opening Limits (%)

LP Valve Opening Rate Limits (%/second)

LP Valve Closing Rate Limits (%/second)

LP Turbine Time Constant (in seconds)

Reheater Time Constant (in seconds)

Boiler Time Constant (in seconds)

HP Power Fraction (%)  
IP Power Fraction (%)

(iii) Governor and associated prime mover  
Parameters - Gas Turbine Units

Inlet Guide Vane Time Constant (in seconds)  
Inlet Guide Vane Opening Limits (%)  
Inlet Guide Vane Opening Rate Limits  
(%/second)  
Inlet Guide Vane Closing Rate Limits  
(%/second)  
Fuel Valve Constant (in seconds)  
Fuel Valve Opening Limits (%)  
Fuel Valve Opening Rate Limits (%/second)  
Fuel Valve Closing Rate Limits (%/second)

Waste Heat Recovery Boiler Time Constant (in  
seconds)

(iv) Governor and associated prime mover  
Parameters - Hydro Generating Units

Guide Vane Actuator Time Constant (in  
seconds)  
Guide Vane Opening Limits (%)  
Guide Vane Opening Rate Limits (%/second)  
Guide Vane Closing Rate Limits (%/second)  
Water Time Constant (in seconds)

[End of Option 2]

(e) Unit Control Options

The following data items need only be supplied with  
respect to **Large Power Stations**:

Maximum droop %  
Normal droop %  
Minimum droop %

Maximum **Frequency** deadband  
 $\pm$ Hz  
Normal **Frequency** deadband  
 $\pm$ Hz  
Minimum **Frequency** deadband  
 $\pm$ Hz

Maximum output deadband  
 $\pm$ MW  
Normal output deadband  
 $\pm$ MW

**Minimum output deadband**  
**±MW**

Frequency settings between which Unit Load Controller droop applies:

-	<b>Maximum</b>	<b>Hz</b>
-	<b>Normal</b>	<b>Hz</b>
-	<b>Minimum</b>	<b>Hz</b>

State if sustained response is normally selected.

(f) **Plant Flexibility Performance**

The following data items need only be supplied with respect to **Large Power Stations**, and should be provided with respect to each **Genset**:

- # Run-up rate to **Registered Capacity**,
- # Run-down rate from **Registered Capacity**,
- # **Synchronising Generation**,
- Regulating range
- Load** rejection capability while still **Synchronised** and able to supply **Load**.

Data items marked with a hash (#) should be applicable to a **Genset** which has been **Shutdown** for 48 hours.

- \* Data items marked with an asterisk are already requested under part 1, PC.A.3.3.1, to facilitate an early assessment by **NGC** as to whether detailed stability studies will be required before an offer of terms for a **CUSC Contract** can be made. Such data items have been repeated here merely for completeness and need not, of course, be resubmitted unless their values, known or estimated, have changed.

**PC.A.5.4 Non-Synchronous Generating Unit and Associated Control System Data**

**PC.A.5.4.1 The data submitted below are not intended to constrain any Ancillary Services Agreement**

**PC.A.5.4.2 The following Power Park Unit, Power Park Module and Power Station parameters data should be supplied in the case of a Power Park Module not connected to the Total System by a DC Converter:**

**(a) Power Park Unit parameters**

- Rated MVA
- Rated Terminal Voltage
- Inertia Constant (MWsec/MVA)

Stator Resistance.  
Stator Reactance.  
Magnetising Reactance.  
Rotor Resistance.  
Rotor Reactance.

The optimal rotor power coefficient ( $C_p$ ) versus tip speed ratio curve where applicable. The tip speed ratio is defined as  $\Omega R/U$  where  $\Omega$  is the angular velocity of the rotor, R is the radius of the wind turbine rotor and U is the wind speed.

Where applicable the electrical power versus rotor speed for a range of wind speeds. Where applicable, the transfer function block diagram including parameters should be provided including the torque speed controller (maximum power tracking control system)

Note: Rotor resistance and reactance values should be given for both starting and running conditions.

Additionally for Doubly Fed Induction Generators the following information is also required:

- (i) The rotor speed range.
- (ii) Power Converter Rating (MVA)
- (iii) Transfer function block diagram, parameters and description of the operation of the power electronic converter including the torque speed controller.

For a **Power Park Unit** consisting of a synchronous machine in combination with a back to back **DC Converter** the information should be given in accordance with the applicable sections of PC.A.5.4.3.1 and PC.A.5.4.3.2 together with the inertia constant and symmetrical three phase short-circuit current infeed after subtransient contribution has significantly decayed at the machine side of the back to back **DC Converter**.

- (b) Voltage/Reactive Power/Power Factor Control System parameters

For the **Power Park Unit** and **Power Park Module** details of Voltage/Reactive Power/Power Factor controller (and PSS if fitted) described in block diagram form showing transfer functions and parameters of individual elements.

- (c) Frequency Control System parameters

For the **Power Park Unit** and **Power Park Module** details of the frequency controller described in block diagram form showing transfer functions and parameters of individual elements.

(d) Protection

Details of settings for the following protection relays: Under frequency, Over Frequency, Under Voltage, Over Voltage, Rate of Change of Frequency, Rotor Over current, Stator Over current, High Wind Speed Shut Down Level.

(e) Harmonic and Flicker Parameters

When connecting a Power Park Module, it is necessary for NGC to evaluate the production of flicker and harmonics on NGC and User's Systems. At NGC's reasonable request, the User is required to submit the following data (as defined in IEC 61400-21 (2001)) for each Power Park Unit:-  
Flicker coefficient for continuous operation.  
Flicker step factor.  
Number of switching operations in a 10 minute window.  
Number of switching operations in a 2 hour window.  
Voltage change factor.  
Harmonic Current Injection.

PC.A.5.4.3

**DC Converter**

PC.A.5.4.3.1

For a **DC Converter** at a **DC Converter Station** or a **Power Park Module** connected to the **Total System** by a **DC Converter** the following information for **DC Converter** and **DC Network** should be supplied:

(a) **DC Converter** Parameters

**Rated MW** per pole for transfer in each direction;  
**DC Converter** type (i.e. current or voltage source);  
Number of poles and pole arrangement;  
Rated DC voltage/pole (kV);  
Return path arrangement;

(b) **DC Converter** Transformer Parameters

Rated MVA  
Nominal primary voltage (kV);  
Nominal secondary (converter-side) voltage(s) (kV);  
Winding and earthing arrangement;  
Positive phase sequence reactance at minimum, maximum and nominal tap;

Positive phase sequence resistance at minimum, maximum and nominal tap;  
Zero phase sequence reactance;  
Tap-changer range in %;  
number of tap-changer steps;

(c) **DC Network Parameters**

Rated DC Voltage per pole;  
Rated DC Current per pole;  
Single line diagram of the complete **DC Network**;  
Details of the complete **DC Network**, including resistance, inductance and capacitance of all DC cables and/or DC lines;  
Details of any DC reactors (including DC reactor resistance), DC capacitors and/or DC-side filters that form part of the **DC Network**;

(d) **AC Filter Reactive Compensation Equipment Parameters**

Note: The data provided pursuant to this paragraph must not include any contribution from reactive compensation plant owned by **NGC**.

Total number of AC filter banks.  
Single line diagram of filter arrangement and connections;  
**Reactive Power** rating for each AC filter bank ,capacitor bank or operating range of each item of reactive compensation equipment, at rated voltage;  
Performance Chart showing **Reactive Power** capability of the **DC Converter**, as a function of MW transfer, with all filters and reactive compensation plant, belonging to the **DC Converter Station** working correctly.

Note: Details in PC.A.5.4.3.1 are required for each **DC Converter** connected to the **DC Network**, unless each is identical or where the data has already been submitted for an identical **DC Converter** at another **Connection Point**.

Note: For a **Power Park Module** connected to the **Grid Entry point** or (**User System Entry Point** if Embedded) by a **DC Converter** the equivalent inertia and fault infeed at the **Power Park Unit** should be given.

**DC Converter Control System Models**

**PC.A.5.4.3.2**

The following data is required by **NGC** to represent **DC Converters** and associated **DC Networks** in dynamic power system simulations, in which the AC power system is typically represented by a positive sequence equivalent. **DC Converters** are represented by simplified equations and are not modelled to switching device level.

- (i) Static  $V_{DC}$ - $I_{DC}$  (DC voltage - DC current) characteristics, for both the rectifier and inverter modes for a current source converter. Static  $V_{DC}$ - $P_{DC}$  (DC voltage - DC power) characteristics, for both the rectifier and inverter modes for a voltage source converter. Transfer function block diagram including parameters representation of the control systems of each **DC Converter** and of the **DC Converter Station**, for both the rectifier and inverter modes. A suitable model would feature the **DC Converter** firing angle as the output variable.
- (ii) Transfer function block diagram representation including parameters of the **DC Converter** transformer tap changer control systems, including time delays
- (iii) Transfer function block diagram representation including parameters of AC filter and reactive compensation equipment control systems, including any time delays.
- (iv) Transfer function block diagram representation including parameters of any frequency and/or load control systems.
- (v) Transfer function block diagram representation including parameters of any small signal modulation controls such as power oscillation damping controls or sub-synchronous oscillation damping controls, that have not been submitted as part of the above control system data
- (vi) Transfer block diagram representation of the reactive power control at converter ends for a voltage source converter.

#### Plant Flexibility Performance

##### PC.A.5.4.3.3

The following information on plant flexibility and performance should be supplied:

- (i) Nominal and maximum (emergency) loading rate with the **DC Converter** in rectifier mode.
- (ii) Nominal and maximum (emergency) loading rate with the **DC Converter** in inverter mode.
- (iii) Maximum recovery time, to 90% of pre-fault loading, following an AC system fault or severe voltage depression.
- (iv) Maximum recovery time, to 90% of pre-fault loading, following a transient **DC Network** fault.

##### PC.A.5.4.3.4

#### Harmonic Assessment Information

DC Converter owners shall provide such additional further information as required by NGC in order that compliance with CC.6.1.5 can be demonstrated.

PC.A.5.45 Response data for Frequency changes

The information detailed below is required to describe the actual frequency response capability profile as illustrated in Figure CC.A.3.1 of the **Connection Conditions**, and need only be provided for each **Genset** at a **Large Power Stations**.

In this **PC.A.5.4**, for a **CCGT Module** with more than one **Generating Unit**, the phrase **Minimum Generation** applies to the entire **CCGT Module** operating with all **Generating Units Synchronised** to the **System**. Similarly for a **Power Park Module** with more than one **Power Park Unit**, the phrase **Minimum Generation** applies to the entire **Power Park Module** operating with all **Power Park Units Synchronised** to the **System**.

PC.A.5.45.1 MW loading points at which data is required

Response values are required at six MW loading points (MLP1 to MLP6) for each **Genset**. **Primary** and **Secondary Response** values need not be provided for MW loading points which are below **Minimum Generation**. MLP1 to MLP6 must be provided to the nearest MW.

Prior to the **Genset** being first **Synchronised**, the MW loading points must take the following values :-

MLP1	<b>Designed Minimum Operating Level</b>
MLP2	<b>Minimum Generation</b>
MLP3	<b>70% of Registered Capacity</b>
MLP4	<b>80% of Registered Capacity</b>
MLP5	<b>95% of Registered Capacity</b>
MLP6	<b>Registered Capacity</b>

When data is provided after the **Genset** is first **Synchronised**, the MW loading points may take any value between **Designed Minimum Operating Level** and **Registered Capacity** but the value of the **Designed Minimum Operating Level** must still be provided if it does not form one of the MW loading points.

PC.A.5.45.2 **Primary and Secondary Response to Frequency fall**

**Primary** and **Secondary Response** values for a -0.5Hz ramp are required at six MW loading points (MLP1 to MLP6) as detailed above

PC.A.5.45.3 **High Frequency Response to Frequency rise**

**High Frequency Response** values for a +0.5Hz ramp are required at six MW loading points (MLP1 to MLP6) as detailed above.

- PC.A.6            **USERS' SYSTEM DATA**
- PC.A.6.1            **Introduction**
- PC.A.6.1.1        Each **User**, whether connected directly via an existing **Connection Point** to the **NGC Transmission System** or seeking such a direct connection, shall provide **NGC** with data on its **User System** which relates to the **Connection Site** containing the **Connection Point** both current and forecast, as specified in PC.A.6.2 to PC.A.6.6.
- PC.A.6.1.2        Each **User** must reflect the system effect at the **Connection Site(s)** of any third party **Embedded** within its **User System** whether existing or proposed.
- PC.A.6.1.3        PC.A.6.2, and PC.A.6.4 to PC.A.6.6 consist of data which is only to be supplied to **NGC** at **NGC's** reasonable request. In the event that **NGC** identifies a reason for requiring this data, **NGC** shall write to the relevant **User(s)**, requesting the data, and explaining the reasons for the request. If the **User(s)** wishes, **NGC** shall also arrange a meeting at which the request for data can be discussed, with the objective of identifying the best way in which **NGC's** requirements can be met.
- PC.A.6.2            **Transient Overvoltage Assessment Data**
- PC.A.6.2.1        It is occasionally necessary for **NGC** to undertake transient overvoltage assessments (e.g. capacitor switching transients, switchgear transient recovery voltages, etc). At **NGC's** reasonable request, each **User** is required to provide the following data with respect to the **Connection Site**, current and forecast, together with a **Single Line Diagram** where not already supplied under PC.A.2.2.1, as follows:-
- (a) busbar layout plan(s), including dimensions and geometry showing positioning of any current and voltage transformers, through bushings, support insulators, disconnectors, circuit breakers, surge arresters, etc. Electrical parameters of any associated current and voltage transformers, stray capacitances of wall bushings and support insulators, and grading capacitances of circuit breakers;
  - (b) Electrical parameters and physical construction details of lines and cables connected at that busbar. Electrical parameters of all plant e.g., transformers (including neutral earthing impedance or zig-zag transformers, if any), series reactors and shunt compensation equipment connected at that busbar (or to the tertiary of a transformer) or by lines or cables to that busbar;
  - (c) Basic insulation levels (BIL) of all **Apparatus** connected directly, by lines or by cables to the busbar;

- (d) characteristics of overvoltage **Protection** devices at the busbar and at the termination points of all lines, and all cables connected to the busbar;
- (e) fault levels at the lower voltage terminals of each transformer connected directly or indirectly to the **NGC Transmission System** without intermediate transformation;
- (f) the following data is required on all transformers operating at **Supergrid Voltage**: three or five limb cores or single phase units to be specified, and operating peak flux density at nominal voltage;
- (g) an indication of which items of equipment may be out of service simultaneously during **Planned Outage** conditions.

PC.A.6.3

### **User's Protection Data**

PC.A.6.3.1

#### **Protection**

The following information is required which relates only to **Protection** equipment which can trip or inter-trip or close any **Connection Point** circuit-breaker or any **NGC** circuit-breaker. This information need only be supplied once, in accordance with the timing requirements set out in PC.A.1.4(b), and need not be supplied on a routine annual basis thereafter, although **NGC** should be notified if any of the information changes

- (a) a full description, including estimated settings, for all relays and **Protection** systems installed or to be installed on the **User's System**;
- (b) a full description of any auto-reclose facilities installed or to be installed on the **User's System**, including type and time delays;
- (c) a full description, including estimated settings, for all relays and **Protection** systems or to be installed on the generator, generator transformer, **Station Transformer** and their associated connections;
- (d) for **Generating Units** (other than Power Park Units) or Power Park Modules having (or intended to have) a circuit breaker at the generator terminal voltage, clearance times for electrical faults within the **Generating Unit** (other than a Power Park Unit) or Power Park Module zone;
- (e) the most probable fault clearance time for electrical faults on any part of the **User's System** directly connected to the **NGC Transmission System**.

PC.A.6.4 Harmonic Studies

PC.A.6.4.1 It is occasionally necessary for **NGC** to evaluate the production/magnification of harmonic distortion on **NGC** and **User's Systems**, especially when **NGC** is connecting equipment such as capacitor banks. At **NGC's** reasonable request, each **User** is required to submit data with respect to the **Connection Site**, current and forecast, and where not already supplied under PC.A.2.2.4 and PC.A.2.2.5, as follows:-

PC.A.6.4.2 Overhead lines and underground cable circuits of the **User's Subtransmission System** must be differentiated and the following data provided separately for each type:-

Positive phase sequence resistance;  
Positive phase sequence reactance;  
Positive phase sequence susceptance;

and for all transformers connecting the **User's Subtransmission System** to a lower voltage:-

Rated MVA;  
Voltage Ratio;  
Positive phase sequence resistance;  
Positive phase sequence reactance;

and at the lower voltage points of those connecting transformers:-

Equivalent positive phase sequence susceptance;  
Connection voltage and Mvar rating of any capacitor bank and component design parameters if configured as a filter;  
Equivalent positive phase sequence interconnection impedance with other lower voltage points;  
The minimum and maximum **Demand** (both MW and Mvar) that could occur;  
Harmonic current injection sources in Amps at the Connection voltage points. Where the harmonic injection current comes from a diverse group of sources, the equivalent contribution may be established from appropriate measurements;  
Details of traction loads, eg connection phase pairs, continuous variation with time, etc;  
An indication of which items of equipment may be out of service simultaneously during **Planned Outage** conditions.

PC.A.6.5 Voltage Assessment Studies

It is occasionally necessary for **NGC** to undertake detailed voltage assessment studies (e.g., to examine potential voltage instability, voltage control co-ordination or to calculate voltage step changes). At **NGC's** reasonable request, each **User** is required to submit the following data where not already supplied under PC.A.2.2.4 and PC.A.2.2.5:-

For all circuits of the **User's Subtransmission System**:-

Positive Phase Sequence Reactance;  
Positive Phase Sequence Resistance;  
Positive Phase Sequence Susceptance;  
Mvar rating of any reactive compensation equipment;

and for all transformers connecting the **User's Subtransmission System** to a lower voltage:-

Rated MVA;  
Voltage Ratio;  
Positive phase sequence resistance;  
Positive Phase sequence reactance;  
Tap-changer range;  
Number of tap steps;  
Tap-changer type: on-load or off-circuit;  
AVC/tap-changer time delay to first tap movement;  
AVC/tap-changer inter-tap time delay;

and at the lower voltage points of those connecting transformers:-

Equivalent positive phase sequence susceptance;  
Mvar rating of any reactive compensation equipment;  
Equivalent positive phase sequence interconnection impedance with other lower voltage points;  
The maximum **Demand** (both MW and Mvar) that could occur;  
Estimate of voltage insensitive (constant power) load content in % of total load at both winter peak and 75% off-peak load conditions.

PC.A.6.6

Short Circuit Analysis:

PC.A.6.6.1

Where prospective short-circuit currents on equipment owned, operated or managed by **NGC** are greater than 90% of the equipment rating, and in **NGC's** reasonable opinion more accurate calculations of short-circuit currents are required, then at **NGC's** request each **User** is required to submit data with respect to the **Connection Site**, current and forecast, and where not already supplied under PC.A.2.2.4 and PC.A.2.2.5, as follows:

PC.A.6.6.2

For all circuits of the **User's Subtransmission System**:-

Positive phase sequence resistance;  
Positive phase sequence reactance;  
Positive phase sequence susceptance;  
Zero phase sequence resistance (both self and mutuals);  
Zero phase sequence reactance (both self and mutuals);  
Zero phase sequence susceptance (both self and mutuals);

and for all transformers connecting the **User's Subtransmission System** to a lower voltage:-

Rated MVA;  
Voltage Ratio;  
Positive phase sequence resistance (at max, min and nominal tap);  
Positive Phase sequence reactance (at max, min and nominal tap);  
Zero phase sequence reactance (at nominal tap);  
Tap changer range;  
Earthing method: direct, resistance or reactance;  
Impedance if not directly earthed;

and at the lower voltage points of those connecting transformers:-

The maximum **Demand** (in MW and Mvar) that could occur;  
Short-circuit infeed data in accordance with PC.A.2.5.6 unless the **User's** lower voltage network runs in parallel with the **User's Subtransmission System**, when to prevent double counting in each node infeed data, a  $\pi$  equivalent comprising the data items of PC.A.2.5.6 for each node together with the positive phase sequence interconnection impedance between the nodes shall be submitted.

PC.A.7

**ADDITIONAL DATA FOR NEW TYPES OF POWER STATIONS, DC CONVERTER STATIONS AND CONFIGURATIONS**

Notwithstanding the **Standard Planning Data** and **Detailed Planning Data** set out in this Appendix, as new types of configurations and operating arrangements of **Power Stations and DC Converter Stations** emerge in future, **NGC** may reasonably require additional data to represent correctly the performance of such **Plant** and **Apparatus** on the **System**, where the present data submissions would prove insufficient for the purpose of producing meaningful **System** studies for the relevant parties.

PLANNING CODE APPENDIX B

Single Line Diagram

The diagrams below show ~~two~~ three examples of single line diagrams, showing the detail that should be incorporated in the diagram. The first example is for an **Network Operator** connection, the second for a **Generator** connection, ~~the third for a~~ **Power Park Module electrically equivalent system**.

.....

.....

### Power Park Module Single Line Diagram

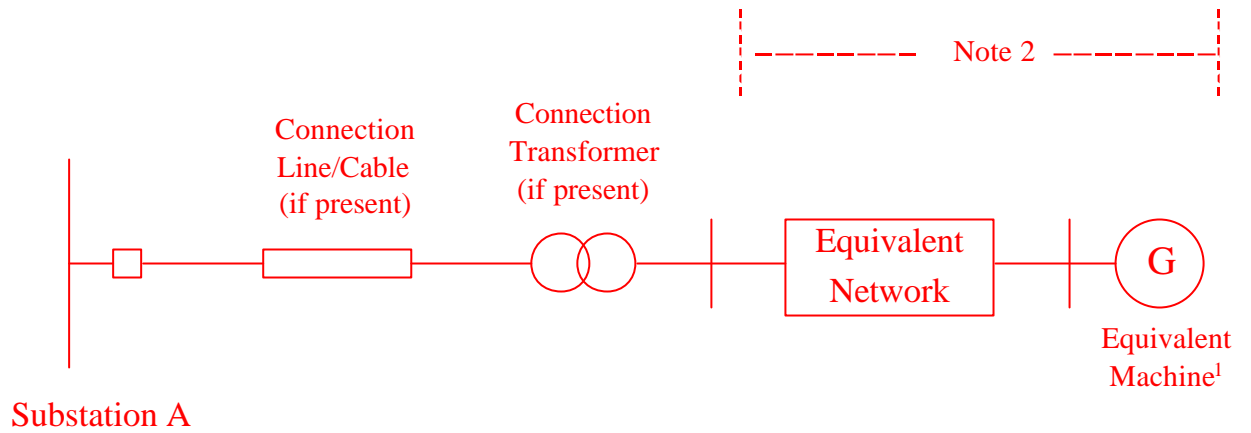

- Notes : 1) It is recommended that this consists of 'N' actual generators i.e. any equipment external to the generator terminals is considered as part of the Equivalent Network
- 2) Where a Power Park Module consists of different Power Park Units, the equivalent machine and network can be repeated for each different unit

**Definitions**

Term	Definition	Notes
------	------------	-------

~~Extracts From The **Generating Unit** Unless otherwise provided in the Grid Code, any Apparatus which produces electricity, including, for the avoidance of doubt, a CCGT Unit~~

**Connection Conditions**

CC.1.1	<p>The <b>Connection Conditions</b> ("CC") specify both the minimum technical, design and operational criteria which must be complied with by any <b>User</b> connected to or seeking connection with the <b>NGC Transmission System</b> or <b>Generators</b> (other than in respect of <b>Small Power Stations</b>) <u>or <b>DC Converter Station owners</b></u> connected to or seeking connection to a <b>User's System</b> which is located in England and/or Wales, and the minimum technical, design and operational criteria with which <b>NGC</b> will comply in relation to the part of the <b>NGC Transmission System</b> at the <b>Connection Site</b> with <b>Users</b>.</p>
CC.3.1	<p>The <b>CC</b> applies to <b>NGC</b> and to <b>Users</b>, which in the <b>CC</b> means:</p> <ul style="list-style-type: none"> <li>(a) <b>Generators</b> (other than those which only have <b>Embedded Small Power Stations</b>)</li> <li>(b) <b>Network Operators</b>;</li> <li>(c) <b>Non-Embedded Customers</b>;</li> <li><u>(d) <b>DC Converter Station owners</b>; and</u></li> <li><u>(d)(e) <b>BM Participants</b> and <b>Externally Interconnected System Operators</b></u> in respect of CC.6.6 only.</li> </ul>
CC.4.1	<p>The <b>CUSC</b> contains provisions relating to the procedure for connection to the <b>NGC Transmission System</b> or, in the case of <b>Embedded Power Stations</b> <u>or <b>Embedded DC Converter Stations</b></u>, becoming operational and includes provisions relating to certain conditions to be complied with by <b>Users</b> prior to <b>NGC</b> notifying the <b>User</b> that it has the right to become operational.</p>
CC.5.1	<p>The provisions relating to connecting to the <b>NGC Transmission System</b> (or to a <b>User's System</b> in the case of a connection of an <b>Embedded Large Power Station</b> or <b>Embedded Medium Power Station</b> <u>or <b>Embedded DC Converter Station</b></u>) are contained in the <b>CUSC</b> and/or <b>CUSC Contract</b> (or in the relevant application form or offer for a <b>CUSC Contract</b>), and include provisions relating to both the submission of information and reports relating to compliance with the relevant <b>Connection Conditions</b> for that <b>User</b>, <b>Safety Rules</b>, commissioning programmes, <b>Operation Diagrams</b> and approval to connect. References in this <b>CC</b> to the "<b>Bilateral Agreement</b>" and/or "<b>Construction Agreement</b>" shall be deemed to include references to the application form or offer therefor.</p>
CC.5.3	<p>As explained in the <b>Bilateral Agreement</b> and/or <b>Construction Agreement</b>, of the list:</p> <ul style="list-style-type: none"> <li><u>(a)</u> items <b>CC.5.2(c)</b>, (e), (g), (h) and (k) need not be supplied in respect of <b>Embedded Power Stations</b> <u>or <b>Embedded DC Converter Stations</b></u>.</li> </ul>

	<p>(b) item <u>CC.5.2(i)</u> need not be supplied in respect of <b>Embedded Small Power Stations</b> or <b>Embedded Medium Power Stations</b> or <b>Embedded DC Converter Stations with a Registered Capacity of less than 100MW</b>, and</p> <p>(c) <u>items CC.5.2(d)</u> and (j) are only needed in the case where the <b>Embedded Power Station</b> or the <b>Embedded DC Converter Station</b> is within a <b>Connection Site</b> with another <b>User</b>.</p>
CC.6.2.1.1	<p>(a) The design of connections between the <b>NGC Transmission System</b> and:-</p> <p>(i) any <b>Generating Unit</b> (other than a <b>CCGT Unit</b> or <b>Power Park Unit</b>), <b>DC Converter</b>, <b>Power Park Module</b> or <b>CCGT Module</b>, or</p> <p>(ii) any <b>Network Operator's User System</b>, or</p> <p>(iii) <b>Non-Embedded Customers</b> equipment, or</p> <p>will be consistent with the <b>Licence Standards</b>.</p>
CC.6.2.2	Requirements relating to <b>Generator</b> or <b>DC Converter Station owner/NGC Connection Points</b>
CC.6.2.2.1	Each connection between a <b>Generating Unit</b> (other than a <b>CCGT Unit</b> or <b>Power Park Unit</b> ), <del>or a</del> <b>CCGT Module</b> , <b>DC Converter</b> or <b>Power Park Module</b> and the <b>NGC Transmission System</b> must be controlled by a circuit breaker capable of interrupting the maximum short circuit current at the point of connection. The <b>Seven Year Statement</b> gives values of short circuit current and the rating of <b>NGC</b> circuit breakers at existing and committed <b>Connection Points</b> for future years.
CC.6.2.2.2.1	<p><u>Minimum Requirements</u></p> <p><b>Protection of Generating Units</b> (other than <b>Power Park Units</b>), <b>DC Converters</b> or <b>Power Park Modules</b> and their connections to the <b>NGC Transmission System</b> must meet the minimum requirements given below. These are necessary to reduce to a practical minimum the impact on the <b>NGC Transmission System</b> of faults on circuits owned</p>
CC.6.2.2.2.2	<p><u>Fault Clearance Times</u></p> <p>.....</p> <p>(b) .....</p> <p>On a <b>Generating Unit</b> (other than <b>Power Park Units</b>), <b>DC Converter</b> or <b>Power Park Module</b> connected to the <b>NGC Transmission System</b> where only one <b>Main Protection</b> is provided to clear faults on the <b>HV Generator Connections</b> within the required fault clearance time, the <b>Back-Up Protection</b> provided by the <b>Generators</b> or <b>DC Converter Station owners</b> shall operate to give a fault clearance time of no slower than 300 ms at the minimum infeed for normal operation for faults on the <b>HV Generator Connections</b>. On <b>Generating Units</b> (other than <b>Power Park Units</b>), <b>DC Converters</b> or <b>Power Park Modules</b> connected to the <b>NGC Transmission System</b> at 400 kV and 275 kV where two <b>Main Protections</b> are provided and on <b>Generating Units</b> (other than <b>Power Park Units</b>), <b>DC Converters</b> or <b>Power Park Modules</b> connected to the <b>NGC Transmission System</b> at 132 kV and below, the <b>Back-Up Protection</b> shall operate to give a fault clearance time of no slower than 800 ms at the minimum infeed for normal operation for faults on the <b>HV Generator Connections</b>.</p>

	<p>.....</p> <p>(c) When the <b>Generating Unit (other than Power Park Unit), DC Converter or Power Park Module</b> is connected to the <b>NGC Transmission System</b> at 400kV or 275kV and a circuit breaker is provided by the <b>Generator, DC Converter Station owner</b> or <b>NGC</b>, as the case may be, to interrupt fault current interchange with the <b>NGC Transmission System, or Generator's System, DC Converter Station owner's System</b>, as the case may be, circuit breaker fail <b>Protection</b> shall be provided by the <b>Generator, DC Converter Station owner</b>, or <b>NGC</b>, as the case may be, on this circuit breaker. In the event, following operation of a <b>Protection</b> system, of a failure to interrupt fault current by these circuit-breakers within the <b>Fault Current Interruption Time</b>, the circuit breaker fail <b>Protection</b> is required to initiate tripping of all the necessary electrically adjacent circuit-breakers so as to interrupt the fault current within the next 200 ms.</p>
CC.6.2.2.3.2	<p><u>Circuit-breaker fail Protection</u></p> <p>The <b>Generator or DC Converter Station owner</b> will install circuit breaker fail <b>Protection</b> equipment in accordance with the requirements of the <b>Bilateral Agreement</b>. The <b>Generator or DC Converter Station owner</b> will also provide a back-trip signal in the event of loss of air from its pressurised head circuit breakers, during the <b>Generating Unit (other than a CCGT Unit or Power Park Unit), or CCGT Module, DC Converter or Power Park Module</b> run-up sequence, where these circuit breakers are installed.</p>
CC.6.2.2.3.5	<p><u>Signals for Tariff Metering</u></p> <p><b>Generators and DC Converter Station owners</b> will install current and voltage transformers supplying all tariff meters at a voltage to be specified in, and in accordance with, the <b>Bilateral Agreement</b>.</p>
CC.6.2.2.4	<p><u>Work on Protection Equipment</u></p> <p>No busbar <b>Protection</b>, mesh corner <b>Protection</b>, circuit-breaker fail <b>Protection</b> relays, AC or DC wiring (other than power supplies or DC tripping associated with the <b>Generating Unit, DC Converter or Power Park Module</b> itself) may be worked upon or altered by the <b>Generator or DC Converter Station owner</b> personnel in the absence of a representative of <b>NGC</b>.</p>
	<p><u>Voltage Waveform Quality</u></p>
CC.6.1.5	<p>All <b>Plant</b> and <b>Apparatus</b> connected to the <b>NGC Transmission System</b>, and that part of the <b>NGC Transmission System</b> at each <b>Connection Site</b>, should be capable of withstanding the following distortions of the voltage waveform in respect of harmonic content and phase unbalance:</p> <p>(a) <u>Harmonic Content</u></p> <p>.....</p> <p><b>Engineering Recommendation G5/4</b> contains planning criteria which <b>NGC</b> will apply to the connection of non-linear <b>Load</b> to the <b>NGC Transmission System</b>, which may result in harmonic emission limits being specified for these <b>Loads</b> in the relevant <b>Bilateral Agreement</b>. The application of the planning criteria will take into account the position of existing and prospective <b>Users' Plant</b> and</p>

	<p><b>Apparatus</b> in relation to harmonic emissions. <b>Users</b> must ensure that connection of distorting loads to their <b>User Systems</b> do not cause any harmonic emission limits specified in the <b>Bilateral Agreement</b> to be exceeded.</p>
CC.6.3	<p>GENERAL <b>GENERATING UNIT, POWER PARK MODULE AND DC CONVERTER</b> REQUIREMENTS</p>
CC.6.3.1	<p>This section sets out the technical and design criteria and performance requirements for <b>Generating Units, DC Converters and Power Park Modules</b> (whether directly connected to the <b>NGC Transmission System</b> or <b>Embedded</b>) which each <b>Generator</b> or <b>DC Converter Station owner</b> must ensure are complied with in relation to its <b>Generating Units, DC Converters and Power Park Modules</b> but does not apply to <b>Small Power Stations or individually to Power Park Units</b>, hydro units and renewable energy plant not designed for <b>Frequency</b> and voltage control. References to <b>Generating Units, DC Converters and Power Park Modules</b> in this CC.6.3 should be read accordingly.</p>
CC.6.3.2.(a)	<p>All <b>Synchronous Generating Units</b> must be capable of supplying rated power output (MW) at any point between the limits 0.85 power factor lagging and 0.95 power factor leading at the <b>Generating Unit</b> terminals. The short circuit ratio of <b>Synchronous Generating Units</b> shall be not less than 0.5.</p>
(b)	<p><u>Subject to paragraph (c) below, all <b>Non-synchronous Generating Units, DC Converters and Power Park Modules</b> must be capable of maintaining zero transfer of <b>Reactive Power</b> at the <b>Grid Entry Point (or User System Entry Point</b> if embedded) at all times and at all active power output levels. The tolerance on <b>Reactive Power</b> transfer to and from the <b>NGC Transmission System</b> will be specified in the <b>Bilateral Agreement</b>.</u></p>
(c)	<p><u>All <b>Non-synchronous Generating Units, DC Converters</b> (excluding current source technology) and <b>Power Park Modules</b> (excluding those connected to the <b>Total System</b> by a current source <b>DC Converter</b>) with a <b>Completion Date</b> after 1 January 2006 must be capable of supplying rated power output (MW) at any point between the limits 0.95 power factor lagging and 0.95 power factor leading at the <b>Grid Entry Point (or User System Entry Point</b> if Embedded). With all plant in service, the reactive power limits defined at rated power will apply at all active power output levels above the <b>Designed Minimum Operating Level</b>. These reactive power limits will be reduced pro rata to the amount of plant in service.</u></p>
CC.6.3.3	<p>Each <b>Generating Unit, DC Converter, Power Park Module</b> and/or <b>CCGT Module</b> must be capable of</p>
(a)	<p>continuously maintaining constant <b>Active Power</b> output for <b>System Frequency</b> changes within the range 50.5 to 49.5 Hz; and</p>
(b)	<p>maintaining its <b>Active Power</b> output at a level not lower than the figure determined by the linear relationship shown in Figure 1 for <b>System Frequency</b> changes within the range 49.5 to 47 Hz, such that if the <b>System Frequency</b> drops to 47 Hz the <b>Active Power</b> output does not decrease by more than 5%.</p>
(c)	

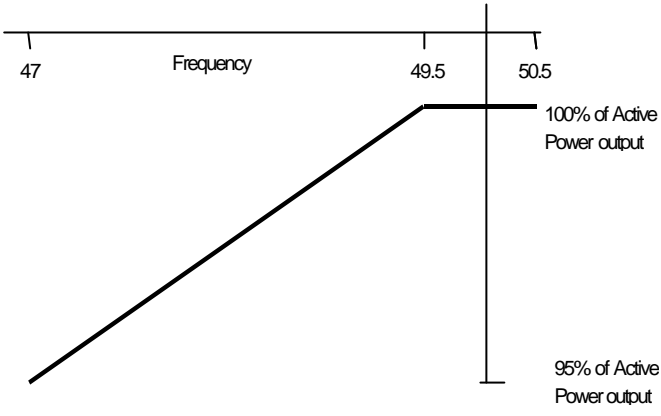
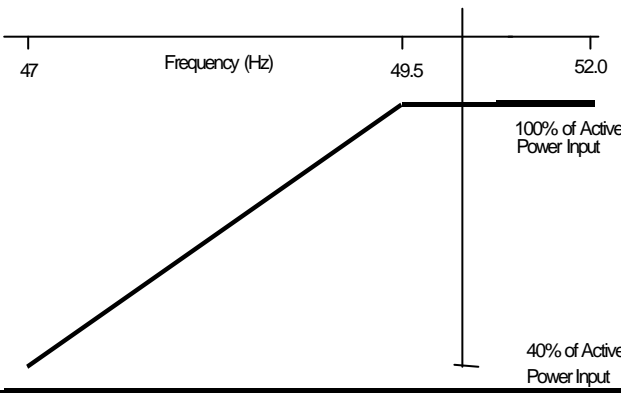
	<p>For the avoidance of doubt in the case of a <b>Generator</b> using an <b>Intermittent Power Source</b> where the mechanical power input will not be constant over time, the requirement is that the <b>Active Power</b> output shall be independent of <b>System Frequency</b> under (a) above and should not drop with <b>System Frequency</b> by greater than the amount specified in (b) above.</p> <p>CC633 Fig 1</p>  <p>(d) A <b>DC Converter Station</b> must be capable of maintaining its <b>Active Power</b> input (i.e., when operating in a mode analogous to <b>Demand</b>) from the <b>NGC Transmission System</b> (or <b>User System</b> in the case of an <b>Embedded DC Converter Station</b>) at a level not greater than the figure determined by the linear relationship shown in Figure 2 for <b>System Frequency</b> changes within the range 49.5 to 47 Hz, such that if the <b>System Frequency</b> drops to 47 Hz the <b>Active Power</b> input decreases by more than 60%.</p> 
<p>CC.6.3.4</p>	<p>The <del>At the Grid Entry Point</del> the <b>Active Power</b> output under steady state conditions of any <b>Generating Unit, DC Converter or Power Park Module</b> directly connected to the <b>NGC Transmission System</b> should not be affected by voltage changes in the normal operating range specified in paragraph CC.6.1.4 <u>by more than the change in Active Power losses at reduced or increased voltage</u>. The <b>Reactive Power</b> output under steady state conditions should be fully available within the voltage range <math>\pm 5\%</math> at 400kV, 275kV and 132kV and lower voltages.</p>
<p>CC.6.3.5</p>	<p>It is an essential requirement that the <b>NGC Transmission System</b> must incorporate a <b>Black Start Capability</b>. This will be achieved by agreeing a <b>Black Start Capability</b> at a number of strategically located <b>Power Stations</b>. For each <b>Power Station</b> NGC will state in the <b>Bilateral Agreement</b> whether or not a <b>Black Start Capability</b> is required.</p>
<p>CC.6.3.6</p>	<p><del>Each <b>Generating Unit</b> must be capable of contributing to <b>Frequency</b> and</del></p>

	<p><del>voltage control by continuous modulation of <b>Active Power and Reactive Power</b> supplied to the <b>NGC Transmission System</b> or the <b>User System</b> in which it is <b>Embedded</b>.</del></p> <p><u>(a) Each <b>Generating Unit, DC Converter</b> (with a <b>Completion Date</b> after 1 January 2004) or <b>Power Park Module</b> (with a <b>Completion Date</b> after 1 January 2006) must be capable of contributing to <b>Frequency</b> control by continuous modulation of <b>Active Power</b> supplied to the <b>NGC Transmission System</b> or the <b>User System</b> in which it is <b>Embedded</b>.</u></p> <p><u>(b) Each <b>Generating Unit, DC Converter</b> (excluding current source technologies or those with a <b>Completion Date</b> before 1 January 2004) or <b>Power Park Module</b> (with a <b>Completion Date</b> after 1 January 2004) must be capable of contributing to voltage control by continuous changes to the <b>Reactive Power</b> supplied to the <b>NGC Transmission System</b> or the <b>User System</b> in which it is <b>Embedded</b>.</u></p>
	<p><b>GOVERNOR SYSTEMS</b></p>
<p>CC.6.3.7 (a)</p>	<p>Each <b>Generating Unit, DC Converter or Power Park Module</b> must be fitted with a fast acting proportional <u>frequency control device</u> ( or turbine speed governor) and unit load controller or equivalent control device to provide <b>Frequency</b> response under normal operational conditions in accordance with <b>Balancing Code 3 (BC3)</b>. -The <u>frequency control device</u> (or speed governor) must be designed and operated to the appropriate:</p> <p>(i) <b>European Specification</b>; or</p> <p>(ii) in the absence of a relevant <b>European Specification</b>, such other standard which is in common use within the European Community;</p> <p>as at the time when the installation of which it forms part was designed or (in the case of modification or alteration to the <u>frequency control device</u> (or turbine speed governor)) when the modification or alteration was designed.</p> <p>The <b>European Specification</b> or other standard utilised in accordance with sub-paragraph CC.6.3.7 (a) (ii) will be notified to <b>NGC</b> as:</p> <p>(i) part of the application for a <b>Bilateral Agreement</b>; or</p> <p>(ii) part of the application for a varied <b>Bilateral Agreement</b>; or</p> <p>(iii) soon as possible prior to any modification or alteration to the <u>frequency control device or governor</u>;</p>
<p>CC.6.3.7 (b)</p>	<p>The <u>frequency control device</u> (or speed governor) in co-ordination with other control devices must control the <b>Generating Unit, DC Converter or Power Park Module</b> <b>Active Power Output</b> with stability over the entire operating range of the <b>Generating Unit, DC Converter or Power Park Module</b>; and</p>
<p>CC.6.3.7(c)</p>	<p>The <u>frequency control device</u> (or speed governor) must meet the following minimum requirements:</p> <p>(i) Where a <b>Generating Unit, DC Converter or Power Park Module</b> becomes isolated from the rest of the <b>Total System</b> but is still supplying <b>Customers</b>, the <u>frequency control device</u> (or speed governor) must also be able to control <b>System Frequency</b> below 52Hz unless this causes the <b>Generating Unit, DC Converter or Power Park Module</b> -to operate below</p>

	<p>its <b>Designed Minimum Operating Level</b> when it is possible that it may, as detailed in BC 3.7.3, trip after a time;</p> <p>(ii) the <del>speed governor</del> <u>frequency control device (or speed governor)</u>, must be capable of being set so that it operates with an overall speed droop of between 3% and 5%;</p> <p>(iii) in the case of all <b>Generating Units, DC Converters or Power Park Modules</b> other than the <b>Steam Unit</b> within a <b>CCGT Module</b> the <u>frequency control device (or speed governor)</u> deadband should be no greater than 0.03Hz (for the avoidance of doubt, <math>\pm 0.015\text{Hz}</math>). In the case of the <b>Steam Unit</b> within a <b>CCGT Module</b>, the speed governor deadband should be set to an appropriate value consistent with the requirements of CC.6.3.7(c)(i) and the requirements of BC3.7.2 for the provision of <b>Limited High Frequency Response</b> ;</p> <p>For the avoidance of doubt, the minimum requirements in (ii) and (iii) for the provision of <b>System Ancillary Services</b> do not restrict the negotiation of <b>Commercial Ancillary Services</b> between <b>NGC</b> and the <b>User</b> using other parameters; and</p>
CC.6.3.7(d)	<p>A facility to modify, so as to fulfil the requirements of the <b>Balancing Codes</b>, the <b>Target Frequency</b> setting either continuously or in a maximum of 0.05 Hz steps over at least the range <math>50 \pm 0.1</math> Hz should be provided in the unit load controller or equivalent device.</p>
CC.6.3.7(e)	<p>(i) Each <b>Generating Unit</b> and/or <b>CCGT Module</b> which has a <b>Completion Date</b> after 1 January 2001 must be capable of meeting the minimum frequency response requirement profile subject to and in accordance with the provisions of Appendix 3.</p> <p><del>(ii) Each <b>DC Converter</b> at a <b>DC Converter Station</b> which has a <b>Completion Date</b> after 1 January 2004 must be capable of meeting the minimum frequency response requirement profile subject to and in accordance with the provisions of Appendix 3.</del></p> <p><del>(iii) Each <b>Power Park Module</b> which has a <b>Completion Date</b> after 1 January 2006 must be capable of meeting the minimum frequency response requirement profile subject to and in accordance with the provisions of Appendix 3.</del></p>
CC.6.3.7(f)	<p>For the avoidance of doubt, the requirements of Appendix 3 do not apply to:-</p> <p>(i) <b>Generating Units</b> and/or <b>CCGT Modules</b> which have a <b>Completion Date</b> before 1 January 2001, for whom the remaining requirements of this clause CC.6.3.7 shall continue to apply unchanged; <u>or</u></p> <p><del>(ii) <b>DC Converters</b> at a <b>DC Converter Station</b> which has a <b>Completion Date</b> before 1 January 2004; or</del></p> <p><del>(iii) <b>Power Park Modules</b> which have a <b>Completion Date</b> before 1 January 2006, for whom only the requirements of clause CC.6.3.7 relevant to the provision of <b>Limited Frequency Sensitive Mode (BC.3.5.2)</b> operation shall continue to apply unchanged.</del></p>

	<b>EXCITATION SYSTEMS</b>
--	---------------------------

<p>CC.6.3.8 (a)</p> <p>(b)</p> <p>(c)</p> <p>(d)</p>	<p>A continuously-acting automatic excitation control system is required to provide constant terminal voltage control of the <b>Synchronous Generating Unit</b> without instability over the entire operating range of the <b>Generating Unit</b>.</p> <p><u>In the case of a <b>Non-synchronous Generating Unit, DC Converter or Power Park Module</b> a continuously-acting automatic control system is required to provide control of the voltage (or power factor as applicable to CC.6.3.2) at the <b>Grid Entry Point</b> or <b>User System Entry Point</b> without instability over the entire operating range of the <b>Non-synchronous Generating Unit, DC Converter or Power Park Module</b>.</u></p> <p>–The requirements for excitation or voltage control facilities, including power system stabilisers, where in <b>NGC's</b> view these are necessary for system reasons, will be specified in the <b>Bilateral Agreement</b>. Reference is made to on-load commissioning witnessed by <b>NGC</b> in BC2.11.2.</p> <p>In particular, other control facilities, including constant <b>Reactive Power</b> output control modes and constant power factor control modes (but excluding VAR limiters) are not required. However, if present in the excitation <u>or voltage control</u> system they will be disabled unless recorded in the <b>Bilateral Agreement</b>. Operation of such control facilities will be in accordance with the provisions contained in <b>BC2</b>.</p>
<p>CC.6.3.9</p>	<p>The standard deviation of <b>Load</b> error at steady state <b>Load</b> over a 30 minute period must not exceed 2.5 per cent of a <b>Genset's Registered Capacity</b>. Where a <b>Genset</b> is instructed to <b>Frequency</b> sensitive operation, allowance will be made in determining whether there has been an error according to the governor droop characteristic registered under the <b>PC</b>.</p> <p><u>For the avoidance of doubt in the case of a <b>Power Park Module</b> allowance will be made for variation of mechanical power input.</u></p>
<p>CC.6.3.10</p>	<p><u>Negative Phase Sequence Loadings</u></p> <p>In addition to meeting the conditions specified in CC.6.1.5(b), each <b>Generating Unit, DC Converter, Power Park Module or constituent element</b> will be required to withstand, without tripping, the negative phase sequence loading incurred by clearance of a close-up phase-to-phase fault, by <b>System Back-Up Protection</b> on the <b>NGC Transmission System</b> or <b>User System</b> in which it is <b>Embedded</b>.</p>
<p>CC.6.3.11</p>	<p><u>Neutral Earthing</u></p> <p>At nominal <b>System</b> voltages of 132kV and above the higher voltage windings of a transformer of a <b>Generating Unit, DC Converter or Power Park Module</b> must be star connected with the star point suitable for connection to earth. The earthing and lower voltage winding arrangement shall be such as to ensure that the <b>Earth Fault Factor</b> requirement of paragraph CC.6.2.1.1 (b) will be met on the <b>NGC Transmission System</b> at nominal <b>System</b> voltages of 132kV and above.</p>
<p>CC.6.3.12</p>	<p><u>Frequency Sensitive Relays</u></p> <p>As stated in CC.6.1.3, the <b>System Frequency</b> could rise to 52Hz or fall to 47Hz. Each <b>Generating Unit, DC Converter, Power Park Module or constituent element</b> must continue to operate within this <b>Frequency</b> range for at least the periods of time given in CC.6.1.3 unless <b>NGC</b> has agreed to any <b>Frequency</b>-level relays and/or rate-of-change-of-<b>Frequency</b> relays which will trip such <b>Generating Unit, DC Converter or Power Park</b></p>

	<b>Module</b> within this <b>Frequency</b> range, under the <b>Bilateral Agreement</b> .
CC.6.3.13	<b>Generators and DC Converter owners</b> will be responsible for protecting all their <b>Generating Units, DC Converters or Power Park Modules</b> against damage should <b>Frequency</b> excursions outside the range 52Hz to 47Hz ever occur. Should such excursions occur, it is up to the <b>Generator</b> to decide whether to disconnect his <b>Apparatus</b> for reasons of safety of <b>Apparatus, Plant</b> and/or personnel.
CC.6.3.14	It may be agreed in the <b>Bilateral Agreement</b> that a <b>Genset</b> shall have a <b>Fast-Start Capability</b> . Such <b>Gensets</b> may be used for <b>Operating Reserve</b> and their <b>Start-Up</b> may be initiated by <b>Frequency</b> -level relays with settings in the range 49Hz to 50Hz as specified pursuant to <b>OC2</b> .
	<b>NGC Transmission System Short Circuit faults</b>
<u>CC.6.3.15</u>	<p><b>(a) Fault Ride Through</b></p> <p><u>Each <b>Generating Unit, DC Converter or Power Park Module</b> shall remain transiently stable and connected to the system without tripping of any <b>Generating Unit, DC Converter or Power Park Module</b> or constituent element, for a close-up solid three-phase fault on the <b>NGC Transmission System operating at Supergrid Voltage</b> for a total fault clearance time of up to 140 ms. It should be noted that a solid three-phase fault results in zero voltage at the point of fault at the instant of fault. Where the sequential clearance of the fault by circuit-breakers results in the duration of zero voltage being less than 140ms, this will be specified in the <b>Bilateral Agreement</b>.</u></p> <p><b>(b) Stability and Loss of Power Infeed</b></p> <p><u>Each <b>Non-synchronous Generating Unit or Power Park Module</b> shall be designed such that the prime mover mechanical power output is not deliberately reduced in response to an <b>NGC Transmission System</b> fault which is cleared within the normal clearance time as indicated in (a) above. It is acknowledged that a small change in prime mover mechanical power output may occur naturally during and immediately after a fault as a result of action taken by controls which may be in operation for other control reasons. Each <b>DC Converter</b> shall be designed to meet the fault recovery characteristics as specified in the <b>Bilateral Agreement</b></u></p>
	<b>Additional Damping Control Facilities for DC Converters</b>
<u>CC.6.3.16</u>	<p><b>(a)</b> <u><b>DC Converter Owners</b> must ensure that any of their <b>DC Converters</b> will not cause a Sub-Synchronous Resonance problem on the <b>Total System</b>. Each <b>DC Converter</b> is required to be provided with Sub-Synchronous Resonance damping control facilities.</u></p> <p><b>(b)</b> <u>Where specified in the <b>Bilateral Agreement</b>, each <b>DC Converter</b> is required to be provided with Power Oscillation damping or any other identified additional control facilities.</u></p>
	<b>Control Telephony</b>
CC.6.5.4	Where <b>NGC</b> requires <b>Control Telephony</b> , <b>Users</b> are required to use the <b>Control Telephony</b> with <b>NGC</b> in respect of all <b>Connection Points</b> with the <b>NGC Transmission System</b> and in respect of all <b>Embedded Large Power Stations and Embedded DC Converter Stations</b> . <b>NGC</b> will install <b>Control Telephony</b> at the <b>User's</b> location where the <b>User's</b> telephony equipment is

	not capable of providing the required facilities or is otherwise incompatible with the <b>NGC Control Telephony</b> . Details of and relating to the <b>Control Telephony</b> required are contained in the <b>Bilateral Agreement</b>
	<u>Operational Metering</u>
CC.6.5.6	<p>(a) <b>NGC</b> shall provide system control and data acquisition (SCADA) outstation interface equipment. The <b>User</b> shall provide such voltage, current, <b>Frequency</b>, <b>Active Power</b> and <b>Reactive Power</b> measurement outputs and plant status indications and alarms to the <b>NGC</b> SCADA outstation interface equipment as required by <b>NGC</b> in accordance with the terms of the <b>Bilateral Agreement</b>.</p> <p>(b) For the avoidance of doubt, for <b>Active Power</b> and <b>Reactive Power</b> measurements, circuit breaker and disconnect status indications from:</p> <p><b>(i) CCGT Modules at Large Power Stations</b>, the outputs and status indications must each be provided to <b>NGC</b> on an individual <b>CCGT Unit</b> basis. In addition, where identified in the <b>Bilateral Agreement</b>, <b>Active Power</b> and <b>Reactive Power</b> measurements from unit and/or station transformers must be provided.</p> <p><b>(i) DC Converters at DC Converter Stations</b>, the outputs and status indications must each be provided to <b>NGC</b> on an individual <b>DC Converter</b> basis. In addition, where identified in the <b>Bilateral Agreement</b>, <b>Active Power</b> and <b>Reactive Power</b> measurements from converter and/or station transformers must be provided.</p> <p><b>(ii) Power Park Modules at Embedded Large Power Stations and at directly connected Power Stations</b> the outputs and status indications must each be provided to <b>NGC</b> on an individual <b>Power Park Module</b> basis. In addition, where identified in the <b>Bilateral Agreement</b>, <b>Active Power</b> and <b>Reactive Power</b> measurements from station transformers must be provided.</p> <p>(c) <u>In the case of a <b>Power Park Module</b> an additional energy input signal (e.g. wind speed) may be specified in the <b>Bilateral Agreement</b>. The signal may be used to establish the level of energy input from the <b>Intermittent Power Source</b> for monitoring pursuant to CC.6.6.1 and <b>Ancillary Services</b> and will, in the case of a wind farm, be used to provide the system operator with advanced warning of excess wind speed shutdown.</u></p>
	<u>Facsimile Machines</u>
CC.6.5.9	Each <b>User</b> and <b>NGC</b> shall provide a facsimile machine or machines:- .....  (c) in the case of <b>Non-Embedded Customers</b> and <b>DC Converter Station owners</b> , at the <b>Control Point</b> .
CC.6.5.10	<u>Busbar Voltage</u>  <b>NGC</b> shall, subject as provided below, provide each <b>Generator or DC Converter Station owner</b> at each <b>Grid Entry Point</b> where one of its <b>Large Power Stations or DC Converter Stations</b> is connected with appropriate voltage signals to enable the <b>Generator or DC Converter Station owner</b> to obtain the necessary information to <del>synchronise</del> <b>permit</b> its <b>Gensets or DC Converters to be Synchronised</b> to the <b>NGC Transmission System</b> . The

	<p>term "<b>voltage signal</b>" shall mean in this context, a point of connection on (or wire or wires from) a relevant part of <b>NGC's Plant</b> and/or <b>Apparatus</b> at the <b>Grid Entry Point</b>, to which the <b>Generator or DC Converter Station owner</b>, with <b>NGC's</b> agreement (not to be unreasonably withheld) in relation to the <b>Plant</b> and/or <b>Apparatus</b> to be attached, will be able to attach its <b>Plant</b> and/or <b>Apparatus</b> (normally a wire or wires) in order to obtain measurement outputs in relation to the busbar.</p>
<p><u>6.5.11</u></p>	<p><u>Bilingual Message Facilities</u></p> <p>(a) <u>A Bilingual Message Facility is the method by which the <b>User's Responsible Engineer/Operator, the Externally Interconnected System Operator and NGC Control Engineers</b> communicate clear and unambiguous information in two languages for the purposes of control of the <b>Total System</b> in both normal and emergency operating conditions.</u></p> <p>(b) <u>A Bilingual Message Facility, where required, will provide up to two hundred pre-defined messages with up to five hundred and sixty characters each. A maximum of one minute is allowed for the transmission to, and display of, the selected message at any destination. The standard messages must be capable of being displayed at any combination of locations and can originate from any of these locations. Messages displayed in the UK will be displayed in the English language.</u></p> <p>(c) <u>Detailed information on a Bilingual Message Facility and suitable equipment required for individual <b>User</b> applications will be provided by <b>NGC</b> upon request.</u></p>
<p>CC.6.6.1</p>	<p>Monitoring equipment is provided on the <b>NGC Transmission System</b> to enable <b>NGC</b> to monitor its power system dynamic performance conditions. Where this monitoring equipment requires voltage and current signals on the <b>Generating Unit (other than Power Park Unit), DC Converter or Power Park Module</b> circuit from the <b>User</b>, <b>NGC</b> will inform the <b>User</b> and they will be provided by the <b>User</b> with both the timing of the installation of the equipment for receiving such signals and its exact position being agreed (the <b>User's</b> agreement not to be unreasonably withheld) and the costs being dealt with, pursuant to the terms of the <b>Bilateral Agreement</b>.</p>
<p>CC.7</p>	<p><u>SITE RELATED CONDITIONS</u></p>
<p><u>CC.7.9</u></p>	<p><u><b>Generators and DC Converter Station owners shall provide a continuously manned Control Point in respect of each Power Station directly connected to the NGC Transmission System. Embedded Large Power Station or DC Converter Station to receive and act upon instructions pursuant to OC7 and BC2.</b></u></p>
<p>CC.8.1</p>	<p><b>System Ancillary Services</b></p> <p>The <b>CC</b> contain requirements for the capability for certain <b>Ancillary Services</b>, which are needed for <b>System</b> reasons ("<b>System Ancillary Services</b>"). There follows a list of these <b>System Ancillary Services</b>, together with the paragraph number of the <b>CC</b> (or other part of the <b>Grid Code</b>) in which the minimum capability is required or referred to. The list is divided into two categories: Part 1 lists the <b>System Ancillary Services</b> which <b>Generators</b> are obliged to provide and <b>DC Converter Station Owners</b> are obliged to have the capability to supply, and Part 2 lists the <b>System Ancillary Services</b> which <b>Generators</b> will provide only if agreement to provide them is reached with <b>NGC</b>:</p>

	<p><u>Part 1</u></p> <p>(a) <b>Reactive Power</b> supplied otherwise than by means of synchronous or static compensators <u>(except in the case of a Power Park Module)</u> – CC.6.3.2</p>
<p>CC.A.1.1.1</p>	<p><u>Types of Schedules</u></p> <p>At all <b>Complexes</b> the following <b>Site Responsibility Schedules</b> shall be drawn up using the proforma attached or with such variations as may be agreed between <b>NGC</b> and <b>Users</b>, but in the absence of agreement the proforma attached will be used:</p> <p>(a) Schedule of <b>HV Apparatus</b></p> <p>(b) Schedule of <b>Plant, LV/MV Apparatus</b>, services and supplies;</p> <p>(c) Schedule of telecommunications and measurements <b>Apparatus</b>.</p> <p>Other than at <b>Generating Unit, DC Converter, Power Park Module</b> and <b>Power Station</b> locations, the schedules referred to in (b) and (c) may be combined.</p>
	<p style="text-align: center;"><u>APPENDIX 3</u></p> <p style="text-align: center;"><b><u>MINIMUM FREQUENCY RESPONSE REQUIREMENT PROFILE AND OPERATING RANGE</u></b>  <b><u>for new Generating Units and/or CCGT Modules with a Completion Date after 1 January 2001 and DC Converter Stations which have a Completion Date after 1 January 2004 and for Power Park Modules which have a Completion Date after 1 January 2006</u></b></p>
<p>CC.A.3.1</p>	<p>SCOPE</p> <p>The frequency response capability is defined in terms of <b>Primary Response, Secondary Response</b> and <b>High Frequency Response</b>. This appendix defines the minimum frequency response requirement profile for each <b>Generating Unit</b> and/or <b>CCGT Module</b> which has a <b>Completion Date</b> after 1 January 2001 <u>and each DC Converter at a DC Converter Station which has a Completion Date after 1 January 2004 and each Power Park Module which has a Completion Date after 1 January 2006</u>. For the avoidance of doubt, this appendix does not apply to <b>Generating Units</b> and/or <b>CCGT Modules</b> which have a Completion Date before 1 January 2001 <u>or DC Converters at a DC Converter Stations which have a Completion Date before 1 January 2004 or Power Park Modules which have a Completion Date before 1 January 2006</u> or to <b>Small Power Stations</b>. The functional definition provides appropriate performance criteria relating to the provision of frequency control by means of frequency sensitive generation in addition to the other requirements identified in CC.6.3.7.</p> <p>In this Appendix 3 to the <b>CC</b>, for a <b>CCGT Module</b> <u>or a Power Park Module</u> with more than one Generating Unit, the phrase <b>Minimum Generation</b> applies to the entire <b>CCGT Module</b> <u>or Power Park Module</u> operating with all <b>Generating Units Synchronised</b> to the System.</p> <p>.....</p>

<p>CC.A.3.2</p>	<p><u>PLANT OPERATING RANGE</u></p> <p>The upper limit of the operating range is the <b>Registered Capacity</b> of the <b>Generating Unit, DC Converter, Power Park Module</b> or <b>CCGT Module</b>.</p> <p>The <b>Minimum Generation</b> level may be less than, but must not be more than, 65% of the <b>Registered Capacity</b>. Each <b>Generating Unit, DC Converter, Power Park Module</b> and/or <b>CCGT Module</b> must be capable of operating satisfactorily down to the <b>Designed Minimum Operating Level</b> as dictated by <b>System</b> operating conditions, although it will not be instructed to below its <b>Minimum Generation</b> level. If a <b>Generating Unit, DC Converter, Power Park Module</b> or <b>CCGT Module</b> is operating below <b>Minimum Generation</b> because of high <b>System Frequency</b>, it should recover adequately to its <b>Minimum Generation</b> level as the <b>System Frequency</b> returns to <b>Target Frequency</b> so that it can provide <b>Primary</b> and <b>Secondary Response</b> from <b>Minimum Generation</b> if the <b>System Frequency</b> continues to fall. For the avoidance of doubt, under normal operating conditions steady state operation below <b>Minimum Generation</b> is not expected. The <b>Designed Minimum Operating Level</b> must not be more than 55% of <b>Registered Capacity</b>.</p> <p>In the event of a <b>Generating Unit, DC Converter, Power Park Module</b> or <b>CCGT Module</b> load rejecting down to no less than its <b>Designed Minimum Operating Level</b> it should not trip as a result of automatic action as detailed in BC3.7. If the load rejection is to a level less than the <b>Designed Minimum Operating Level</b> then it is accepted that the condition might be so severe as to cause it to be disconnected from the <b>System</b>.</p>
<p>CC.A.3.3</p>	<p><u>MINIMUM FREQUENCY RESPONSE REQUIREMENT PROFILE</u></p> <p>Figure CC.A.3.1 shows the minimum frequency response requirement profile diagrammatically for a 0.5 Hz change in <b>Frequency</b>. The percentage response capabilities and loading levels are defined on the basis of the <b>Registered Capacity</b> of the <b>Generating Unit, DC Converter, Power Park Module</b> or <b>CCGT Module</b>. Each <b>Generating Unit, DC Converter, Power Park Module</b> and/or <b>CCGT Module</b> must be capable of operating in a manner to provide frequency response at least to the solid boundaries shown in the figure. If the frequency response capability falls within the solid boundaries, the <b>Generating Unit, DC Converter, Power Park Module</b> or <b>CCGT Module</b> is providing response below the minimum requirement which is not acceptable. Nothing in this appendix is intended to prevent a <b>Generating Unit, DC Converter, Power Park Module</b> or <b>CCGT Module</b> from being designed to deliver a frequency response in excess of the identified minimum requirement.</p> <p>.....</p> <p>Each <b>Generating Unit, DC Converter, Power Park Module</b> and/or <b>CCGT Module</b> must be capable of providing some response, in keeping with its specific operational characteristics, when operating between 95% to 100% of <b>Registered Capacity</b> as illustrated by the dotted lines in Figure CC.A.3.1.</p> <p>At the <b>Minimum Generation</b> level, each <b>Generating Unit, DC Converter, Power Park Module</b> and/or <b>CCGT Module</b> is required to provide high and low frequency response depending on the <b>System Frequency</b> conditions. Where the <b>Frequency</b> is high, the <b>Active Power</b> output is therefore expected to fall below the <b>Minimum Generation</b> level.</p> <p>The <b>Designed Minimum Operating Level</b> is the output at which a</p>

	<p><b>Generating Unit, DC Converter, Power Park Module</b> and/or <b>CCGT Module</b> has no <b>High Frequency Response</b> capability. It may be less than, but must not be more than, 55% of the <b>Registered Capacity</b>. This implies that a <b>Generating Unit, DC Converter, Power Park Module</b> or <b>CCGT Module</b> is not obliged to reduce its output to below this level unless the <b>Frequency</b> is at or above 50.5 Hz (cf BC3.7).</p>
<p>CC.A.3.4</p>	<p><u>TESTING OF FREQUENCY RESPONSE CAPABILITY</u></p> <p>.....</p> <p>The <b>Primary Response</b> capability (P) of a <b>Generating Unit, DC Converter, Power Park Module</b> or a <b>CCGT Module</b> is the minimum increase in <b>Active Power</b> output between 10 and 30 seconds after the start of the ramp injection as illustrated diagrammatically in Figure CC.A.3.2.</p> <p>The <b>Secondary Response</b> capability (S) of a <b>Generating Unit, DC Converter, Power Park Module</b> or a <b>CCGT Module</b> is the minimum increase in <b>Active Power</b> output between 30 seconds and 30 minutes after the start of the ramp injection as illustrated diagrammatically in Figure CC.A.3.2.</p> <p>The <b>High Frequency Response</b> capability (H) of a <b>Generating Unit, DC Converter, Power Park Module</b> or a <b>CCGT Module</b> is the decrease in <b>Active Power</b> output provided 10 seconds after the start of the ramp injection and sustained thereafter as illustrated diagrammatically in Figure CC.A.3.3.</p>
<p>CC.A.3.5</p>	<p><u>REPEATABILITY OF RESPONSE</u></p> <p>When a <b>Generating Unit, DC Converter, Power Park Module</b> or <b>CCGT Module</b> has responded to a significant <b>Frequency</b> disturbance, its response capability must be fully restored as soon as technically possible. Full response capability should be restored no later than 20 minutes after the initial change of <b>System Frequency</b> arising from the <b>Frequency</b> disturbance.</p>

## EXTRACTS FROM OPERATING CODE NO.2

### OC2.1 INTRODUCTION

OC2.1.1 **Operating Code No. 2 ("OC2")** is concerned with:

- (a) the co-ordination of the release of **Gensets**, the **NGC Transmission System** and **Network Operators' Systems** for construction, repair and maintenance;
- (b) provision by **NGC** of the **Surpluses** both for the **NGC Transmission System** and **System Zones**;
- (c) the provision by **Generators** of **Generation Planning Parameters** for **Gensets**, including **CCGT Module Planning Matrices** and Power Park Module Planning Matrices, to **NGC** for planning purposes only; and
- (d) the agreement for release of **Existing Gas Cooled Reactor Plant** for outages in certain circumstances.

OC2.1.2

- (a) **Operational Planning** involves planning, through various timescales, the matching of generation output with forecast **NGC Demand** together with a reserve of generation to provide a margin, taking into account outages of certain **Generating Units**, **Power Park Modules and DC Converters**, and of parts of the **NGC Transmission System** and of parts of **Network Operators' Systems** which is carried out to achieve, so far as possible, the standards of security set out in the **Transmission Licence** or **Electricity Distribution Licence** as the case may be.
- (b) In general terms there is an "envelope of opportunity" for the release of **Gensets** and for the release of parts of the **NGC Transmission System** and parts of the **Network Operator's User Systems** for outages. The envelope is defined by the difference between the total generation output expected from **Large Power Stations, Medium Power Stations** and **Demand**, the operational planning margin and taking into account **External Interconnections**.

.....

#### OC2.4.1.2.3 Operational Planning Phase - Planning for Year 0

The basis for **Operational Planning** for Year 0 will be the revised **Final Generation Outage Programme** agreed for Year 1:

In each week:

- (a) By 1600 hours each Wednesday

Each **Generator** will provide **NGC** in writing with an update of the **Final Generation Outage Programme** and a best estimate **Output Usable** forecast (without allowance being made for **Generating Unit or Power Park Module** breakdown) for each of its **Gensets** from the 2nd week ahead to the 7th week ahead and a best estimate neutral **Output Usable** forecast (with allowance being made for **Generating Unit or Power Park Module** breakdown) for each of its **Gensets** from the 8th week ahead to the 52nd week ahead.

.....

OC2.4.1.2.4 Programming Phase

- (a) By 1200 hours each Friday

**NGC** will notify in writing each **Generator** with **Large Power Stations** and **Network Operator** if it considers the **Output Usable** forecasts will give MW shortfalls both nationally and for constrained groups for the period 2-7 weeks ahead.

- (b) By 1100 hours each Business Day

Each **Generator** shall provide **NGC** in writing (or by such electronic data transmission facilities as have been agreed with **NGC**) with the best estimate of **Output Usable** for each **Genset** for the period from and including day 2 ahead to day 14 ahead, including the forecast return to service date for any such **Generating Unit or Power Park Module** subject to **Planned Outage** or breakdown. For the period 2 to 7 weeks ahead, each **Generator** shall provide **NGC** in writing with changes (start and finish dates) to **Planned Outage** or to the return to service times of each **Genset** which is subject to breakdown.

.....

OC2.4.2 DATA REQUIREMENTS

OC2.4.2.1 When a **Statement of Readiness** under the **Bilateral Agreement** and/or **Construction Agreement** is submitted, and thereafter in calendar week 24 in each calendar year,

- (a) each **Generator** shall in respect of each of its:-
- (i) **Gensets** (in the case of the **Generation Planning Parameters**); and
  - (ii) **CCGT Units** within each of its **CCGT Modules** at a **Large Power Station** (in the case of the **Generator Performance Chart**)

submit to **NGC** in writing the **Generation Planning Parameters** and the **Generator Performance Chart**.

- (b) Each shall meet the requirements of CC.6.3.2 and shall reasonably reflect the true operating characteristics of the **Genset**.
- (c) They shall be applied (unless revised under this **OC2** or (in the case of the **Generator Performance Chart** only) **BC1** in relation to **Other Relevant Data**) from the **Completion Date**, in the case of the ones submitted with the **Statement of Readiness**, and in the case of the ones submitted in calendar week 24, from the beginning of week 25 onwards.
- (d) They shall be in the format indicated in Appendix 1 for these charts and as set out in Appendix 2 for the **Generation Planning Parameters**.
- (e) Any changes to the **Generator Performance Chart** or **Generation Planning Parameters** should be notified to **NGC** promptly.
- (f) **Generators** should note that amendments to the composition of the **CCGT Module** or **Power Park Module** at **Large Power Stations** may only be made in accordance with the principles set out in PC.A.3.2.23 or PC.A.3.2.4 respectively. If in accordance with PC.A.3.2.23 or PC.A.3.2.4 an amendment is made, any consequential changes to the **Generation Planning Parameters** should be notified to **NGC** promptly.
- (g) The **Generator Performance Chart** must be ~~as described below and demonstrate the limitation on reactive capability of the **System** voltage at 3% above nominal. It must also include any limitations on output due to the prime mover (both maximum and minimum), **Generating Unit** step up transformer or **User System**.~~
  - (i) For a **Synchronous Generating Unit**, on a **Generating Unit** specific basis at the **Generating Unit** Stator Terminals ~~and. It must include details of the **Generating Unit** transformer parameters; and demonstrate the limitation on reactive capability of the **System** voltage at 3% above nominal. It must include any limitations on output due to the prime mover (both maximum and minimum) and **Generating Unit** step up transformer.~~
  - (ii) For a **Non-synchronous Generating Unit**, (excluding a **Power Park Unit**) on a **Generating Unit** specific basis at the **Grid Entry Point** (or **User System Entry Point** if **Embedded**).
  - (iii) For a **Power Park Module**, on a **Power Park Module** specific basis at the **Grid Entry Point** (or **User System Entry Point** if **Embedded**).
  - (iv) For a **DC Converter** on a **DC Converter** specific basis at the **Grid Entry Point** (or **User System Entry Point** if **Embedded**).

- (h) For each **CCGT Unit**, and any other **Generating Unit** whose performance varies significantly with ambient temperature, the **Generator Performance Chart** shall show curves for at least two values of ambient temperature so that **NGC** can assess the variation in performance over all likely ambient temperatures by a process of linear interpolation or extrapolation. One of these curves shall be for the ambient temperature at which the **Generating Unit's** output, or **CCGT Module** at a **Large Power Station** output, as appropriate, equals its **Registered Capacity**.
- (i) The **Generation Planning Parameters** supplied under OC2.4.2.1 shall be used by **NGC** for operational planning purposes only and not in connection with the operation of the **Balancing Mechanism** (subject as otherwise permitted in the **BCs**).
- (j) Each **Generator** shall in respect of each of its **CCGT Modules** at **Large Power Stations** submit to **NGC** in writing a **CCGT Module Planning Matrix**. It shall be prepared on a best estimate basis relating to how it is anticipated the **CCGT Module** will be running and which shall reasonably reflect the true operating characteristics of the **CCGT Module**. It will be applied (unless revised under this OC2) from the **Completion Date**, in the case of the one submitted with the **Statement of Readiness**, and in the case of the one submitted in calendar week 24, from the beginning of week 31 onwards. It must show the combination of **CCGT Units** which would be running in relation to any given MW output, in the format indicated in Appendix 3.

Any changes must be notified to **NGC** promptly. **Generators** should note that amendments to the composition of the **CCGT Module** at **Large Power Stations** may only be made in accordance with the principles set out in PC.A.3.2.~~23~~. If in accordance with PC.A.3.2.~~23~~ an amendment is made, an updated **CCGT Module Planning Matrix** must be immediately submitted to **NGC** in accordance with this OC2.4.2.1(b).

The **CCGT Module Planning Matrix** will be used by **NGC** for operational planning purposes only and not in connection with the operation of the **Balancing Mechanism**.

- (k) Each **Generator** shall in respect of each of its **Power Park Modules** at **Large Power Stations** submit to **NGC** in writing a **Power Park Module Planning Matrix**. It shall be prepared on a best estimate basis relating to how it is anticipated the **Power Park Module** will be running and which shall reasonably reflect the operating characteristics of the **Power Park Module**. It will be applied (unless revised under this OC2) from the **Completion Date**, in the case of the one submitted with the **Statement of Readiness**, and in the case of the one submitted in calendar week 24, from the beginning of week 31 onwards. It must show the number of each type of **Power Park Unit** in the **Power Park Module** typically expected to be available to generate, in the format indicated in Appendix 4. The **Power Park Module Planning**

Matrix shall be accompanied by a graph showing the variation in MW output with Intermittent Power Source (e.g. MW vs wind speed) for the Power Park Module. The graph shall indicate the typical value of the Intermittent Power Source for the Power Park Module.

Any changes must be notified to NGC promptly. Generators should note that amendments to the composition of the Power Park Module at Large Power Stations may only be made in accordance with the principles set out in PC.A.3.2.4. If in accordance with PC.A.3.2.4 an amendment is made, an updated Power Park Module Planning Matrix must be immediately submitted to NGC in accordance with this OC2.4.2.1(a).

The Power Park Module Planning Matrix will be used by NGC for operational planning purposes only and not in connection with the operation of the Balancing Mechanism.

OC2.4.2.2 Each **Network Operator** shall by 1000 hrs on the day falling seven days before each **Operational Day** inform **NGC** in writing of any changes to the circuit details called for in PC.A.2.2.1 which it is anticipated will apply on that **Operational Day** (under **BC1** revisions can be made to this data).

.....

OC2.4.4 FREQUENCY SENSITIVE OPERATION

By 1600 hours each Wednesday

OC2.4.4.1 Using such information as **NGC** shall consider relevant including, if appropriate, forecast **Demand**, any estimates provided by **Generators** of **Genset** inflexibility and anticipated plant mix relating to operation in **Frequency Sensitive Mode**, **NGC** shall determine for the period 2 to 7 weeks ahead (inclusive) whether it is possible that there will be insufficient **Gensets** (other than those **Gensets** within **Existing Gas Cooled Reactor Plant** which are permitted to operate in **Limited Frequency Sensitive Mode** at all times under BC3.5.3) to operate in **Frequency Sensitive Mode** for all or any part of that period.

OC2.4.4.2 BC3.5.3 explains that **NGC** permits **Existing Gas Cooled Reactor Plant** other than **Frequency Sensitive AGR Units** to operate in a **Limited Frequency Sensitive Mode** at all times.

OC2.4.4.3 If **NGC** foresees that there will be an insufficiency in **Gensets** operating in a **Frequency Sensitive Mode**, it will contact **Generators** in order to seek to agree (as soon as reasonably practicable) that all or some of the ~~**Gensets Generating Units comprising each Generator's relevant Large Power Stations**~~ (the MW amount being determined by **NGC** but the ~~**Gensets Generating Units**~~ involved being determined by the **Generator**) will take outages to coincide with such period as **NGC** shall specify to enable replacement by other **Gensets** which can operate in

a **Frequency Sensitive Mode**. If agreement is reached (which unlike the remainder of OC2 will constitute a binding agreement) then such **Generator** will take such outage as agreed with **NGC**. If agreement is not reached, then the provisions of BC2.9.5 may apply.

OC2.4.5 If in **NGC's** reasonable opinion it is necessary for both the procedure set out in OC2.4.3 (relating to **System NRAPM** and **Localised NRAPM**) and in OC2.4.4 (relating to operation in **Frequency Sensitive Mode**) to be followed in any given situation, the procedure set out in OC2.4.3 will be followed first, and then the procedure set out in OC2.4.4. For the avoidance of doubt, nothing in this paragraph shall prevent either procedure from being followed separately and independently of the other.

.....

**OC2 APPENDIX 4**

**Power Park Module Planning Matrix example form**

<b>POWER PARK UNITS AVAILABLE</b>	<b>POWER PARK UNITS</b>			
	Type A	Type B	Type C	Type D
Description				
Number of units				

The **Power Park Module Planning Matrix** may have as many columns as are required to provide information on the different types of **Power Park Unit** at the **Power Park Module**. The description is required to assist identification of the **Power Park Units** within the **Power Park Module** and correlation with data provided under the **Planning Code**.

< End of OC2 >

## Extracts From Operating Code 5

### OC5.1 INTRODUCTION

**Operating Code No. 5 ("OC5")** specifies the procedures to be followed by **NGC** in carrying out:

- (a) monitoring
  - (i) of **BM Units** against their expected input or output;
  - (ii) of compliance by **Users** with the **CC** and in the case of response to **Frequency, BC3**; and
  - (iii) of the provision by **Users** of **Ancillary Services** which they are required or have agreed to provide; and
- (b) the following tests (which are subject to **System** conditions prevailing on the day):
  - (i) tests on **Gensets and DC Converters** to test that they have the capability to comply with the **CC** and, in the case of response to **Frequency, BC3** and to provide the **Ancillary Services** that they are either required or have agreed to provide;
  - (ii) tests on **BM Units**, to ensure that the **BM Units** are available in accordance with their submitted **Export and Import Limits, QPNs, Joint BM Unit Data** and **Dynamic Parameters**.

The **OC5** tests include the **Black Start Test** procedure.

### OC5.2 OBJECTIVE

The objectives of **OC5** are to establish:

- (a) that **Users** comply with the **CC**;
- (b) whether **BM Units** operate in accordance with their expected input or output derived from their **Final Physical Notification Data** and agreed **Bid-Offer Acceptances** issued under **BC2**;
- (c) whether each **BM Unit** is available as declared in accordance with its submitted **Export and Import Limits, QPN, Joint BM Unit Data** and **Dynamic Parameters**; and
- (d) whether **Generators, DC Converter Station owners** and **Suppliers** can provide those **Ancillary Services** which they are either required or have agreed to provide.

In certain limited circumstances as specified in this **OC5** the output of **CCGT Units** may be verified, namely the monitoring of the provision of **Ancillary Services** and the testing of **Reactive Power** and automatic **Frequency Sensitive Operation**.

OC5.3 SCOPE

**OC5** applies to **NGC** and to **Users**, which in **OC5** means:

- (a) **Generators;**
- (b) **Network Operators;**
- (c) **Non-Embedded Customers; and**
- (d) **Suppliers; and**
- (e) **DC Converter Station owners.**

.....

OC5.4.2.2 The relevant **User** will, as soon as possible, provide **NGC** with an explanation of the reasons for the failure and details of the action that it proposes to take to:

- (a) enable the **BM Unit** to meet its expected input or output or to provide the **Ancillary Services** it is required or has agreed to provide, within a reasonable period, or
- (b) in the case of a **Generating Unit** (excluding a Power Park Unit), or CCGT Module, Power Park Module or DC Converter to comply with the **CC** and in the case of response to **Frequency, BC3** or to provide the **Ancillary Services** it is required or has agreed to provide, within a reasonable period.

.....

OC5.5.1.2 The test, referred to in OC5.5.1.1 and carried out at a time no sooner than 48 hours from the time that the instruction was issued, on any one or more of the **User's BM Units** should only be to demonstrate that the relevant **BM Unit**:

- (a) if active in the **Balancing Mechanism**, meets the ability to operate in accordance with its submitted **Export and Import Limits, QPN, Joint BM Unit Data** and **Dynamic Parameters** and achieve its expected input or output which has been monitored under OC5.4; and
- (b) meets the requirements of the paragraphs in the **CC** which are applicable to such **BM Units**; and

in the case of a **BM Unit** comprising a **Generating Unit, or a CCGT Module, a Power Park Module or a DC Converter** meets,

- (c) the requirements for operation in **Frequency Sensitive Mode** and compliance with the requirements for operation in **Limited**

**Frequency Sensitive Mode** in accordance with CC.6.3.3, BC3.5.2 and BC3.7.2; or

- (d) the terms of the applicable **Supplemental Agreement** agreed with the **Generator** to have a **Fast Start Capability**; or
- (e) the **Reactive Power** capability registered with **NGC** under **OC2** which shall meet the requirements set out in CC.6.3.2. In the case of a test on a **Generating Unit** within a **CCGT Module** the instruction need not identify the particular **CCGT Unit** within the **CCGT Module** which is to be tested, but instead may specify that a test is to be carried out on one of the **CCGT Units** within the **CCGT Module**.

.....

OC5.5.2.2 If monitoring at site is undertaken, the performance of the **BM Unit** will be recorded on a suitable recorder (with measurements, in the case of a **Synchronous Generating Unit**, taken on the **Generating Unit** Stator Terminals / on the **LV** side of the generator transformer) or in the case of a **Non-synchronous Generating Unit, Power Park Module or DC Converter** at the point of connection, in the relevant **User's Control Room**, in the presence of a reasonable number of representatives appointed and authorised by **NGC**. If **NGC** or the **User** requests, monitoring at site will include measurement of the following parameters:

- (a) for Steam Turbines: governor pilot oil pressure, valve position and steam pressure; or
- (b) for Gas Turbines: Inlet Guide Vane position, Fuel Valve positions, Fuel Demand signal and Exhaust Gas temperature; or
- (c) for Hydro Turbines: Governor Demand signal, Actuator Output signal, Guide Vane position; and/or
- (d) for Excitation Systems: Generator Field Voltage and **Power System Stabiliser** signal where appropriate.

(e) for **Power Park Modules**: appropriate signals related to the voltage/reactive/power factor control system and the frequency control system as agreed at the time of connection.

(f) for **DC Converters**: appropriate signals related to the voltage/reactive/power factor control system and the frequency control system as agreed at the time of connection.

.....

OC5.5.3

Test and Monitoring Assessment

The pass criteria must be read in conjunction with the full text under the Grid Code reference. The **BM Unit** will pass the test if the criteria below are met:

Parameter to be Tested	Grid Code Reference	Pass Criteria (to be read in conjunction with the full text under the Grid Code reference)
Harmonic Content	CC.6.1.5(a)	Measured harmonic emissions do not exceed the limits specified in the <b>Bilateral Agreement</b> .
Phase Unbalance	CC.6.1.5(b)	The measured maximum <b>Phase (Voltage) Unbalance</b> on the <b>NGC Transmission System</b> should remain below 1%.
Phase Unbalance	CC.6.1.6	Measured infrequent short duration peaks in phase unbalance should not exceed the maximum value stated in the <b>Bilateral Agreement</b> .
Voltage Fluctuations	CC.6.1.7(a)	Measured voltage fluctuations at the <b>Point of Common Coupling</b> shall not exceed 1% of the voltage level for step changes. Measured voltage excursions other than step changes may be allowed up to a level of 3%.
Flicker	CC.6.1.7(b)	Measured voltage fluctuations at the <b>Point of Common Coupling</b> shall not exceed the <b>Flicker Severity (Short Term)</b> of 0.8 Unit and a <b>Flicker Severity (Long Term)</b> of 0.6 Unit, as set out in <b>Engineering Recommendation P28</b> as current at the <b>Transfer Date</b> .
Voltage Quality		



Parameter to be Tested	Grid Code Reference	Pass Criteria (to be read in conjunction with the full text under the Grid Code reference)
Fault Clearance Times	CC.6.2.2.2.2(a) CC.6.2.3.1.1(a)	The fault clearance times shall be in accordance with the <b>Bilateral Agreement</b> .
<b>Back-Up Protection</b>	CC.6.2.2.2.2(b) CC.6.2.3.1.1(b)	The <b>Back-Up Protection</b> system provided by <b>Generators</b> operates in the times specified in CC.6.2.2.2.2(b). The <b>Back-Up Protection</b> system provided by <b>Network Operators and Non-Embedded Customers</b> operates in the times specified in CC.6.2.3.1.1(b) and with <b>Discrimination</b> as specified in the <b>Bilateral Agreement</b> .
Circuit Breaker fail <b>Protection</b>	CC.6.2.2.2.2(c) CC.6.2.3.1.1(c)	The circuit breaker fail <b>Protection</b> shall initiate tripping so as to interrupt the fault current within 200ms.
Reactive Capability	CC.6.3.2  CC.6.3.4	The <b>Generating Unit</b> , <b>DC Converter or Power Park Module</b> will pass the test if it is within $\pm 5\%$ of the reactive capability registered with <b>NGC</b> under <b>OC2</b> which shall meet the requirements set out in CC.6.3.2.  The duration of the test will be for a period of up to 60 minutes during which period the <b>System</b> voltage at the <b>Grid Entry Point</b> for the relevant <b>Generating Unit</b> , <b>DC Converter or Power Park Module</b> will be maintained by the <b>Generator</b> at the voltage specified pursuant to BC2.8 by adjustment of <b>Reactive Power</b> on the remaining <b>Generating Units</b> , <b>DC Converter or Power Park Module</b> , if necessary.  Measurements of the <b>Reactive Power</b> output under steady state conditions should be consistent with Grid Code requirements i.e. fully available within the voltage range $\pm 5\%$ at 400kV, 275kV and 132kV and lower voltages.
Reactive Capability		

Parameter to be Tested	Grid Code Reference	Pass Criteria (to be read in conjunction with the full text under the Grid Code reference)
<b>Primary, Secondary and High Frequency Response</b>		The measured response in MW/Hz is within $\pm 5\%$ of the level of response specified in the <b>Ancillary Services Agreement</b> for that <b>Genset</b> .
Stability with Voltage	CC.6.3.4	The measured <b>Active Power</b> output under steady state conditions of any <b>Generating Unit, DC Converter or Power Park Module</b> directly connected to the <b>NGC Transmission System</b> should not be affected by voltage changes in the normal operating range.
Governor / <u>Frequency Control System</u> Standard	CC.6.3.7(a)	Measurements indicate that the Governor/ <u>frequency control system</u> parameters are within the criteria set out in the appropriate governor/ <u>frequency control system</u> standard (the version of which to apply being determined within CC.6.3.7).
Governor / <u>Frequency Control System</u> Stability	CC.6.3.7(b)	The measured <b>Generating Unit, DC Converter or Power Park Module Active Power Output</b> shall be stable over the entire operating range of the <b>Generating Unit, DC Converter or Power Park Module</b> .
Governor / <u>Frequency Control</u> Droop	CC.6.3.7(c)(ii)	The measured speed governor / <u>frequency control</u> overall <b>speed</b> droop should be between 3% and 5%.
Governor/ <u>Frequency Control</u> Deadband	CC.6.3.7.(c)(iii)	Except for the <b>Steam Unit</b> within a <b>CCGT Module</b> , the measured speed governor / <u>frequency control</u> deadband shall be no greater than 0.03Hz (for the avoidance of doubt, $\pm 0.015\text{Hz}$ ).
<b>Target Frequency</b>	CC.6.3.7(d)	<b>Target Frequency</b> settings over at least the range $50 \pm 0.1$ Hz shall be available.
Response Capability	CC.6.3.7(e) CC.A.3	The measured frequency response of each <b>Generating Unit</b> and/or <b>CCGT Module</b> which has a <b>Completion Date</b> after 1 January 2001 shall meet requirement profile contained in <b>Connection Conditions</b> Appendix 3. <u>Similarly for DC Converters with Completion Dates after 1 January 2004 and Power Park Modules with Completion Dates after 1 January 2006.</u>
<b>Limited High Frequency Response</b>	BC3.7.2(b)	The measured response is within the requirements of BC3.7.2. i.e. the measured rate of change of <b>Active Power</b> output must be at least 2% of output per 0.1Hz deviation of <b>System Frequency</b> above 50.4Hz.
Output at reduced <b>System Frequency</b>	CC.6.3.3 BC3.5.1	For variations in <b>System Frequency</b> exceeding 0.1Hz within a period of less than 10 seconds, the <b>Active Power</b> output is within $\pm 0.2\%$ of the requirements of CC.6.3.3 when monitored at prevailing external air temperatures of up to 25°C.

Governor / Frequency Control System Compliance

Parameter to be Tested	Grid Code Reference	Pass Criteria (to be read in conjunction with the full text under the Grid Code reference)
<b>Fast Start</b>		The <b>Fast Start Capability</b> requirements of the <b>Ancillary Services Agreement</b> for that <b>Genset</b> are met.
<b>Black Start</b>	OC:5.7.1	The relevant <b>Generating Unit or Power Park Module</b> is <b>Synchronised</b> to the <b>System</b> within two hours of the <b>Auxiliary Gas Turbine(s)</b> or <b>Auxiliary Diesel Engine(s)</b> being required to start.
<b>Excitation / Voltage Control System</b>	CC:6.3.8(a) & BC2.11.2	Measurements of the continuously acting automatic excitation/ <u>voltage</u> control system are required to demonstrate the provision of constant terminal voltage <u>or power factor</u> control of the <b>Generating Unit</b> , <u>DC Converter or Power Park Module as applicable</u> without instability over the entire operating range of the <b>Generating Unit, DC Converter or Power Park Module</b> . The measured performance of the automatic excitation/ <u>voltage</u> control system should also meet the requirements (including <b>Power System Stabiliser</b> performance) specified in the <b>Bilateral Agreement</b> .

Pass Criteria	
Parameter to be Tested	Grid Code Reference
<b>Export and Import Limits, QPN, Joint BM Unit Data and Dynamic Parameters</b>	OC5
<p>The <b>Export and Import Limits, QPN, Joint BM Unit Data and Dynamic Parameters</b> under test are within 2½% of the declared value being tested.</p> <p>The duration of the test will be consistent with and sufficient to measure the relevant expected input or output derived from the <b>Final Physical Notification Data and Bid-Offer Acceptances</b> issued under BC2 which are still in dispute following the procedure in OC5.4.2.</p>	
<b>Synchronisation time</b>	BC2.5.2.3
<p><b>Synchronisation</b> takes place within ±5 minutes of the time it should have achieved <b>Synchronisation</b>.</p> <p>The duration of the test will be consistent with and sufficient to measure the relevant expected input or output derived from the <b>Final Physical Notification Data and Bid-Offer Acceptances</b> issued under BC2 which are still in dispute following the procedure in OC5.4.2.</p>	
<b>Run-up rates</b>	OC5
<p>Achieves the instructed output and, where applicable, the first and/or second intermediate breakpoints, each within ±3 minutes of the time it should have reached such output and breakpoints from <b>Synchronisation</b> (or break point, as the case may be), calculated from the run-up rates in its <b>Dynamic Parameters</b>.</p> <p>The duration of the test will be consistent with and sufficient to measure the relevant expected input or output derived from the <b>Final Physical Notification Data and Bid-Offer Acceptances</b> issued under BC2 which are still in dispute following the procedure in OC5.4.2.</p>	
<b>Run-down rates</b>	OC5
<p>Achieves the instructed output within ±5 minutes of the time, calculated from the run-down rates in its <b>Dynamic Parameters</b>.</p> <p>The duration of the test will be consistent with and sufficient to measure the relevant expected input or output derived from the <b>Final Physical Notification Data and Bid-Offer Acceptances</b> issued under BC2 which are still in dispute following the procedure in OC5.4.2.</p>	
<b>Dynamic Parameters</b>	

Due account will be taken of any conditions on the **System** which may affect the results of the test. The relevant **User** must, if requested, demonstrate, to **NGC's**

reasonable satisfaction, the reliability of the suitable recorders, disclosing calibration records to the extent appropriate.

OC5.6.2

If a **BM Unit** fails the test, the **User** shall submit revised **Export and Import Limits, QPN, Joint BM Unit Data** and/or **Dynamic Parameters**, or in the case of a **BM Unit** comprising a **Generating Unit, ~~or a CCGT Module, DC Converter or Power Park Module~~**, the **User** may amend, with **NGC's** approval, the relevant registered parameters of that **Generating Unit, ~~or CCGT Module, DC Converter or Power Park Module~~**, as the case may be, relating to the criteria, for the period of time until the **BM Unit** can achieve the parameters previously registered, as demonstrated in a re-test.

.....

<End of OC5>

## EXTRACTS FROM OPERATING CODE NO.7

### OPERATIONAL LIAISON

.....

#### OC7.3 SCOPE

OC7.3.1 **OC7** applies to **NGC** and to **Users**, which in **OC7** means:-

- (a) **Generators** (other than those which only have **Embedded Small Power Stations** or **Embedded Medium Power Stations**);
- (b) **Network Operators**;
- (c) **Non-Embedded Customers**;
- (d) **Suppliers** (for the purposes of **NGC System Warnings**); ~~and~~
- (e) **Externally Interconnected System Operators** (for the purposes of **NGC System Warnings**); ~~and~~
- (f) **DC Converter Station owners.**

The procedure for operational liaison by **NGC** with **Externally Interconnected System Operators** is set out in the **Interconnection Agreement** with each **Externally Interconnected System Operator**.

.....

#### OC7.4.5.4 Operations caused by another Operation or by an Event

.....

OC7.4.5.7 Where an **Operation** on the **NGC Transmission System** falls to be reported by **NGC** under an **Interconnection Agreement** and the **Operation** has been caused by another **Operation** (the "first **Operation**") or by an **Event** on a **User's System**, **NGC** will include in that report the information which **NGC** has been given in relation to the first **Operation** or that **Event** by the **User** (including any information relating to an incident or scheduled or planned action, as provided in OC7.4.5.6).

OC7.4.5.8 (a) A notification to a **User** by **NGC** of an **Operation** under OC7.4.5.1 which has been caused by the equivalent of an **Operation** or of an **Event** on the equivalent of a **System** of an **Externally Interconnected System Operator** or **Interconnector User**, will describe the **Operation** on the **NGC Transmission System** and will contain the information which **NGC** has been given, in relation to the equivalent of an **Operation** or of an **Event** on the equivalent of a **System** of an **Externally Interconnected System Operator** or **Interconnector User**, by that **Externally Interconnected System Operator** or **Interconnector User**.

- (b) The notification and any response to any question asked (other than in relation to the information which **NGC** is merely passing on from that **Externally Interconnected System Operator** or **Interconnector User**) will be of sufficient detail to enable the recipient of the notification reasonably to consider and assess the implications and risks arising from the **Operation** on the **NGC Transmission System** and will include the name of the individual reporting the **Operation** on behalf of **NGC**. The recipient may ask questions to clarify the notification and **NGC** will, insofar as it is able, answer any questions raised, provided that, in relation to the information which **NGC** is merely passing on from an **Externally Interconnected System Operator** or **Interconnector User**, in answering any question **NGC** will not pass on anything further than that which it has been told by the **Externally Interconnected System Operator** or **Interconnector User** which has notified it.
- OC7.4.5.9 (a) A **Network Operator** may pass on the information contained in a notification to it from **NGC** under OC7.4.5.1, to a **Generator** with a **Generating Unit** or **Power Park Module** connected to its **System**, or to a **DC Converter Station** owner with a **DC Converter** connected to its **System**, or to the operator of another **User System** connected to its **System** (which, for the avoidance of doubt, could be another **Network Operator**), in connection with reporting the equivalent of an **Operation** under the **Distribution Code** (or the contract pursuant to which that **Generating Unit** or **Power Park Module** or other **User System**, or to a **DC Converter Station** is connected to the **System** of that **Network Operator**) (if the **Operation** on the **NGC Transmission System** caused it).
- (b) A **Generator** may pass on the information contained in a notification to it from **NGC** under OC7.4.5.1, to another **Generator** with a **Generating Unit** or **Power Park Module** connected to its **System**, or to the operator of a **User System** connected to its **System** (which, for the avoidance of doubt, could be a **Network Operator**), if it is required (by a contract pursuant to which that **Generating Unit** or that **Power Park Module** or that **User System** is connected to its **System**) to do so in connection with the equivalent of an **Operation** on its **System** (if the **Operation** on the **NGC Transmission System** caused it).
- OC7.4.5.10 (a) Other than as provided in OC7.4.5.9, a **Network Operator** or a **Generator** or a **DC Converter Station** owner may not pass on any information contained in a notification to it from **NGC** under OC7.4.5.1 (and an operator of a **User System** or **Generator** or **DC Converter Station** owner receiving information which was contained in a notification to a **Generator** or **DC Converter Station** owner or a **Network Operator**, as the case may be, from **NGC** under OC7.4.5.1, as envisaged in OC7.4.5.9 may not pass on this information) to any other person, but may inform persons connected to its **System** (or in the case of a **Generator** or a **DC Converter Station** owner which is also a **Supplier**, inform

persons to which it supplies electricity which may be affected) that there has been an incident on the **Total System**, the general nature of the incident (but not the cause of the incident) and (if known and if power supplies have been affected) an estimated time of return to service.

- (b) In the case of a **Generator** or a **DC Converter Station owner** which has an **Affiliate** which is a **Supplier**, the **Generator** or a **DC Converter Station owner** may inform it that there has been an incident on the **Total System**, the general nature of the incident (but not the cause of the incident) and (if known and if power supplies have been affected in a particular area) an estimated time of return to service in that area, and that **Supplier** may pass this on to persons to which it supplies electricity which may be affected).
- (c) Each **Network Operator** and **Generator** and **DC Converter Station owner** shall use its reasonable endeavours to procure that any **Generator** or operator of a **User System** receiving information which was contained in a notification to a **Generator** or **Network Operator** or **DC Converter Station owner**, as the case may be, from **NGC** under OC7.4.5.1, which is not bound by the **Grid Code**, does not pass on any information other than as provided above.

.....

OC7.4.6.8 Where an **Event** on the **NGC Transmission System** falls to be reported by **NGC** under an **Interconnection Agreement** and the **Event** has been caused by (or exacerbated by) another **Event** (the "first **Event**") or by an **Operation** on a **User's System**, **NGC** will include in that report the information which **NGC** has been given in relation to the first **Event** or that **Operation** by the **User** (including any information relating to an incident or scheduled or planned action on that **User's System**, as provided in OC7.4.6.7).

- OC7.4.6.9
- (a) A notification to a **User** (and any response to any questions asked under OC7.4.6.1) by **NGC** of (or relating to) an **Event** under OC7.4.6.1 which has been caused by (or exacerbated by) the equivalent of an **Event** or of an **Operation** on the equivalent of a **System** of an **Externally Interconnected System Operator** or **Interconnector User**, will describe the **Event** on the **NGC Transmission System** and will contain the information which **NGC** has been given, in relation to the equivalent of an **Event** or of an **Operation** on the equivalent of a **System** of an **Externally Interconnected System Operator** or **Interconnector User**, by that **Externally Interconnected System Operator** or **Interconnector User** (but otherwise need not state the cause of the **Event**).
  - (b) The notification and any response to any questions asked (other than in relation to the information which **NGC** is merely passing on from that **Externally Interconnected System Operator** or **Interconnector User**) will be of sufficient detail to enable the

recipient of the notification reasonably to consider and assess the implications and risks arising from the **Event** on the **NGC Transmission System** and will include the name of the individual reporting the **Event** on behalf of **NGC**. The recipient may ask questions to clarify the notification and **NGC** will, insofar as it is able (although it need not state the cause of the **Event**) answer any questions raised, provided that, in relation to the information which **NGC** is merely passing on from an **Externally Interconnected System Operator** or **Interconnector User**, in answering any question **NGC** will not pass on anything further than that which it has been told by the **Externally Interconnected System Operator** or **Interconnector User** which has notified it.

- OC7.4.6.10 (a) A **Network Operator** may pass on the information contained in a notification to it from **NGC** under OC7.4.6.1, to a **Generator** with a **Generating Unit** or a **Power Park Module** connected to its **System** or to a **DC Converter Station owner with a DC Converter connected to its System** or to the operator of another **User System** connected to its **System** (which, for the avoidance of doubt, could be a **Network Operator**), in connection with reporting the equivalent of an **Event** under the **Distribution Code** (or the contract pursuant to which that **Generating Unit** or **Power Park Module** or **DC Converter** or other **User System** is connected to the **System** of that **Network Operator**) (if the **Event** on the **NGC Transmission System** caused or exacerbated it).
- (b) A **Generator** may pass on the information contained in a notification to it from **NGC** under OC7.4.6.1, to another **Generator** with a **Generating Unit** or a **Power Park Module** connected to its **System** or to the operator of a **User System** connected to its **System** (which, for the avoidance of doubt, could be a **Network Operator**), if it is required (by a contract pursuant to which that **Generating Unit** or that **Power Park Module** or that **User System** is connected to its **System**) to do so in connection with the equivalent of an **Event** on its **System** (if the **Event** on the **NGC Transmission System** caused or exacerbated it).
- OC7.4.6.11 (a) Other than as provided in OC7.4.6.10, a **Network Operator** or a **Generator** or a **DC Converter Station owner**, may not pass on any information contained in a notification to it from **NGC** under OC7.4.6.1 (and an operator of a **User System** or **Generator** or **DC Converter Station owner** receiving information which was contained in a notification to a **Generator** , **DC Converter Station owner** or a **Network Operator**, as the case may be, from **NGC** under OC7.4.6.1, as envisaged in OC7.4.6.10 may not pass on this information) to any other person, but may inform persons connected to its **System** (or in the case of a **Generator** or **DC Converter Station owner** which is also a **Supplier**, inform persons to which it supplies electricity which may be affected) that there has been an incident on the **Total System**, the general nature of the incident (but not the cause of the incident) and (if

known and if power supplies have been affected) an estimated time of return to service.

- (b) In the case of a **Generator or DC Converter Station owner** which has an **Affiliate** which is a **Supplier**, the **Generator or DC Converter Station owner** may inform it that there has been an incident on the **Total System**, the general nature of the incident (but not the cause of the incident) and (if known and if power supplies have been affected in a particular area) an estimated time of return to service in that area, and that **Supplier** may pass this on to persons to which it supplies electricity which may be affected).
- (c) Each **Network Operator** and **Generator and DC Converter Station owner** shall use its reasonable endeavours to procure that any **Generator** or operator of a **User System** receiving information which was contained in a notification to a **Generator or Network Operator or DC Converter Station owner**, as the case may be, from **NGC** under OC7.4.6.1, which is not bound by the **Grid Code**, does not pass on any information other than as provided above.

OC7.4.6.12 When an **Event** relating to a **Generating Unit , Power Park Module or DC Converter**, has been reported to **NGC** by a **Generator or DC Converter Station owner** under OC7.4.6 and it is necessary in order for the **Generator or DC Converter Station owner** to assess the implications of the **Event** on its **System** more accurately, the **Generator or DC Converter Station owner** may ask **NGC** for details of the fault levels from the **NGC Transmission System** to that **Generating Unit , Power Park Module or DC Converter** at the time of the **Event**, and **NGC** will, as soon as reasonably practicable, give the **Generator or DC Converter Station owner** that information provided that **NGC** has that information.

.....

## OC7.5 PROCEDURE IN RELATION TO INTEGRAL EQUIPMENT TESTS

OC7.5.1 This section of the **Grid Code** deals with **Integral Equipment Tests**. It is designed to provide a framework for the exchange of relevant information and for discussion between **NGC** and certain **Users** in relation to **Integral Equipment Tests**.

OC7.5.2 An **Integral Equipment Test** :-

- (a) is carried out in accordance with the provisions of this OC7.5 at:-
  - i) a **User Site**,
  - ii) an **NGC site**, or,
  - iii) an **Embedded Large Power Station; or,**
  - iv) an **Embedded DC Converter Station;**

.....

Response to notification of an IET

- OC7.5.7 The recipient of notification of an **IET** must respond within a reasonable timescale prior to the start time of the **IET** and will not unreasonably withhold or delay acceptance of the **IET** proposal.
- OC7.5.8 (a) Where **NGC** receives notification of a proposed **IET** from a **User**, **NGC** will consult those other **Users** whom it reasonably believes may be affected by the proposed **IET** to seek their views. Information relating to the proposed **IET** may be passed on by **NGC** with the prior agreement of the proposer. However it is not necessary for **NGC** to obtain the agreement of any such **User** as **IETs** should not involve the application of irregular, unusual or extreme conditions. **NGC** may however consider any comments received when deciding whether or not to agree to an **IET**.
- (b) In the case of an **Embedded Large Power Station** or Embedded DC Converter Station, the **Generator** or DC Converter Station owner as the case may be must liaise with both **NGC** and the relevant **Network Operator**. **NGC** will not agree to an **IET** relating to such **Plant** until the **Generator** or DC Converter Station owner has shown that it has the agreement of the relevant **Network Operator**.
- (c) A **Network Operator** will liaise with **NGC** as necessary in those instances where it is aware of an **Embedded Small Power Station** or an **Embedded Medium Power Station** which intends to perform tests which in the reasonable judgement of the **Network Operator** may cause an **Operational Effect** on the **NGC Transmission System**.

.....

**NGC SYSTEM WARNINGS TABLE**

OC7 APPENDIX

Grid Code	FORMAT	to : for ACTION	to : for INFORMATION	TIMESCALE	WARNING OF/OR CONSEQUENCE	Response From Recipients
OC7.4.8.5	Fax or other electronic means	Generators, Suppliers, <b>External</b>	Network Operators, Non-Embedded Customers	All timescales when at the time there is not a high risk of Demand reduction. Primarily 1200 hours onwards for a future period.	Insufficient generation available to meet forecast Demand plus Operating Margin Notification that if not improved Demand reduction may be instructed. (Normal initial warning of insufficient System Margin)	Offers of increased availability from Generators or <b>DC Converter Station owner</b> and Interconnector Users. Suppliers notify NGC of any additional Customer Demand Management that they will initiate.
OC7.4.8.6	Fax or other electronic means	Generators, Suppliers, Network Operators, Non-Embedded Customers, Externally Interconnected System Operators, <b>DC Converter Station owners</b>		All timescales where there is a high risk of Demand reduction. Primarily 1200 hours onwards for a future period.	Insufficient generation available to meet forecast Demand plus Operating Margin and /or a high risk of Demand reduction being instructed.  (May be issued locally as Demand reduction risk only for circuit overloads)	Offers of increased availability from Generators or <b>DC Converter Station owner</b> and Interconnector Users. Suppliers notify NGC of any additional Customer Demand Management that they will initiate.  Specified Network Operators and Non-Embedded Customers to prepare their Demand reduction arrangements and take actions as necessary to enable compliance with NGC instructions that may follow.  (Percentages of Demand reduction above 20 % may not be achieved if NGC has not issued the warning by 16:00 hours the previous day).
OC7.4.8.7	Fax/ Telephone or other electronic means	<b>Specified Users only:</b> (to whom an instruction is to be given) Network Operators, Non-Embedded Customers	None	within 30 minutes of anticipated instruction.	Possibility of Demand reduction within 30 minutes.	Network Operators specified to prepare to take action as necessary to enable them to comply with any subsequent NGC instruction for Demand reduction.
OC7.4.8.8	Fax/ Telephone or other electronic means	Generators, <b>DC Converter Station owners</b> , Network Operators, Non-Embedded Customers, Externally Interconnected System Operators	Suppliers	Control room timescales	Risk of, or widespread system disturbance to whole or part of NGC system	Recipients take steps to warn operational staff and maintain plant or apparatus such that they are best able to withstand the disturbance.

<p><b>WARNING TYPE</b></p>	<p><b>GC SYSTEM WARNING -</b> Inadequate System Margin</p>	<p><b>NGC SYSTEM WARNING -</b> High Risk of Demand Reduction</p>	<p><b>NGC SYSTEM WARNING -</b> Demand Control Imminent</p>	<p><b>NGC SYSTEM WARNING -</b> Risk of System Disturbance</p>
----------------------------	--	--	--	---

**EXTRACTS FROM OPERATING CODE NO.10**EVENT INFORMATION SUPPLY

.....

OC10.3 SCOPEOC10.3.1 **OC10** applies to **NGC** and to **Users**, which in **OC10** means:-

- (a) **Generators** (other than those which only have **Embedded Small Power Stations** and/or **Embedded Medium Power Stations**);
- (b) **Network Operators**; ~~and~~
- (c) **Non-Embedded Customers**; and
- (d) **DC Converter Station owners**

The procedure for **Event** information supply between **NGC** and **Externally Interconnected System Operators** is set out in the **Interconnection Agreement** with each **Externally Interconnected System Operator**.

.....

OC10.4.1.2 Written Reporting of **Events** by **NGC** to **Users**

In the case of an **Event** which was initially reported by **NGC** to a **User** orally and subsequently determined by the **User** to be a **Significant Incident**, and accordingly notified by the **User** to **NGC** pursuant to **OC7**, **NGC** will give a written report to the **User**, in accordance with **OC10**. The **User** will not pass on the report to other affected **Users** but:

- (a) a **Network Operator** may use the information contained therein in preparing a written report to a **Generator** with a **Generating Unit or Power Park Module** connected to its **System** or to a **DC Convert Station owner with a DC Converter connected to its System** or to another operator of a **User System** connected to its **System** in connection with reporting the equivalent of a **Significant Incident** under the **Distribution Code** (or other contract pursuant to which that **Generating Unit or that Power Park Module or that DC Converter** or **User System** is connected to its **System**) (if the **Significant Incident** on the **NGC Transmission System** caused or exacerbated it); and
- (b) a **Generator** may use the information contained therein in preparing a written report to another **Generator** with a **Generating Unit or Power Park Module** connected to its **System** or to the operator of a **User System** connected to its **System** if it is required (by a contract pursuant to which that **Generating Unit or Power Park Module** or that is connected to its **System**) to do so in connection with the equivalent of a

**Significant Incident** on its **System** (if the **Significant Incident** on the **NGC Transmission System** caused or exacerbated it).

.....

OC10.4.2 Joint Investigations

.....

OC10.4.2.3 **NGC** or a **User** may also request that:-

- (i) an **Externally Interconnected System Operator** and/or
- (ii) **Interconnector User** or
- (iii) (in the case of a **Network Operator**) a **Generator** with a **Generating Unit or Power Park Module or a DC Converter Station owner with DC Converter** connected to its **System** or another **User System** connected to its **System** or
- (iv) (in the case of a **Generator**) another **Generator** with a **Generating Unit or Power Park Module** connected to its **System** or a **User System** connected to its **System**,

be included in the joint investigation.

.....

APPENDIX

MATTERS, IF APPLICABLE TO THE SIGNIFICANT INCIDENT

AND TO THE RELEVANT USER (OR NGC, AS THE CASE MAY BE,)

TO BE INCLUDED IN A WRITTEN REPORT

GIVEN IN ACCORDANCE WITH OC10.4.1 AND OC10.4.2

1. Time and date of **Significant Incident**.
2. Location.
3. **Plant** and/or **Apparatus** directly involved (and not merely affected by the **Event**).
4. Description of **Significant Incident**.
5. **Demand** (in MW) and/or generation (in MW) interrupted and duration of interruption.
6. **Generating Unit** **Power Park Module or DC Converter** - **Frequency response** (MW correction achieved subsequent to the **Significant Incident**).

7. **Generating Unit , Power Park Module or DC Converter** - Mvar performance (change in output subsequent to the **Significant Incident**).
8. Estimated time and date of return to service.

EXTRACTS FROM OPERATING CODE NO.11

NUMBERING AND NOMENCLATURE OF  
HIGH VOLTAGE APPARATUS AT CERTAIN SITES

.....

OC11.3        SCOPE

OC11.3.1     **OC11** applies to **NGC** and to **Users**, which in **OC11** means:-

- (a)        **Generators;**
- (b)        **Network Operators; ~~and~~**
- (c)        **Non-Embedded Customers; and**
- (d)        **DC Converter Station owners.**

.....

**EXTRACTS FROM OPERATING CODE NO.12**SYSTEM TESTS

.....

OC12.3

SCOPE

**OC12** applies to **NGC** and to **Users**, which in **OC12** means:-

- (a) **Generators;**
- (b) **Network Operators; ~~and~~**
- (c) **Non-Embedded Customers- ; and**
- (d) **DC Converter Station owners.**

The procedure for the establishment of **System Tests** on the **NGC Transmission System**, with **Externally Interconnected System Operators** which do not affect any **User**, is set out in the **Interconnection Agreement** with each **Externally Interconnected System Operator**. The position of **Externally Interconnected System Operators** and **Interconnector Users** is also referred to in OC12.4.2.

.....

**EXTRACTS FROM BALANCING CODE No 1**.....  
**BC1.4.2**      Day Ahead Submissions  
.....**(a)**      Physical Notifications

**Physical Notifications**, being the data listed in **BC1** Appendix 1 under that heading, are required by **NGC** at 11:00 hours each day for each **Settlement Period** of the next following **Operational Day**, in respect of **BM Units**:-

- (i)              with a **Demand Capacity** with a magnitude of 50MW or more; or
- (ii)             comprising **Generating Units**, **Power Park Modules** and/or **CCGT Modules** in each case at **Large Power Stations** and **Medium Power Stations**; or
- (iii)            where the **BM Participant** chooses to submit **Bid-Offer Data** in accordance with BC1.4.2(d) for **BM Units** not falling within (i) or (ii) above.

**Physical Notifications** may be submitted to **NGC** by **BM Participants**, for the **BM Units** specified in this BC1.4.2(a) at an earlier time, or **BM Participants** may rely upon the provisions of BC1.4.5 to create the **Physical Notifications** by data defaulting pursuant to the **Grid Code** utilising the rules referred to in that paragraph at 11:00 hours in any day.

**Physical Notifications** (which must comply with the limits on maximum rates of change listed in **BC1** Appendix 1) must, subject to the following operating limits, represent the **User's** best estimate of expected input or output of **Active Power** and shall be prepared in accordance with **Good Industry Practice**. **Physical Notifications** for any **BM Unit** should normally be consistent with the **Dynamic Parameters** and **Export and Import Limits** and must not reflect any **BM Unit** proposing to operate outside the limits of its **Demand Capacity** and **Generation Capacity** and, in the case of a **BM Unit** comprising a **Generating Unit**, **Power Park Module** or **CCGT Module**, its **Registered Capacity**.

These **Physical Notifications** provide, amongst other things, indicative **Synchronising** and **De-Synchronising** times to **NGC** in respect of any **BM Unit** comprising a **Generating Unit**, **Power Park Module** or **CCGT Module** and provide an indication of significant **Demand** changes in respect of other **BM Units**.

.....  
**(f)**      Other Relevant Data

By 11:00 hours each day each **BM Participant**, in respect of each of its **BM Units** for which **Physical Notifications** are being submitted, shall, if it has not already done so, submit to **NGC** in respect of the next following **Operational Day** the following:

- (i) in the case of a **CCGT Module**, a **CCGT Module Matrix** as described in **BC1 Appendix 1**;
- (ii) details of any special factors which in the reasonable opinion of the **BM Participant** may have a material effect or present an enhanced risk of a material effect on the likely output (or consumption) of such **BM Unit(s)**. Such factors may include risks, or potential interruptions, to **BM Unit** fuel supplies, or developing plant problems, details of tripping tests, etc. This information will normally only be used to assist in determining the appropriate level of **Operating Margin** that is required under OC2.4.6;
- (iii) in the case of **Generators**, any temporary changes, and their possible duration, to the **Registered Data** of such **BM Unit**;
- (iv) in the case of **Suppliers**, details of **Customer Demand Management** taken into account in the preparation of its **BM Unit Data**; and
- (v) details of any other factors which **NGC** may take account of when issuing **Bid-Offer Acceptances** for a **BM Unit** (e.g., **Synchronising** or **De-Synchronising** Intervals, the minimum notice required to cancel a **Synchronisation**, etc).
- (vi) in the case of a **Power Park Module**, a **Power Park Module Matrix** as described in **BC1 Appendix 1**.

.....

#### BC1.6.1 **User System Data from Network Operators**

- (a) By 1000 hours each day each **Network Operator** will submit to **NGC** in writing, confirmation or notification of the following in respect of the next **Operational Day**:
  - (i) constraints on its **User System** which **NGC** may need to take into account in operating the **NGC Transmission System**. In this BC1.6.1 the term "constraints" shall include restrictions on the operation of **Embedded CCGT Units, and/or Power Park Modules** as a result of the **User System** to which the **CCGT Unit and/or Power Park Module** is connected at the **User System Entry Point** being operated or switched in a particular way, for example, splitting the relevant busbar. It is a matter for the **Network Operator** and the **Generator** to arrange the operation or switching, and to deal with any resulting consequences. The **Generator**, after consultation with the **Network Operator**, is responsible for ensuring that no **BM Unit Data** submitted to **NGC** can result in the violation of any such constraint on the **User System**.

- (ii) the requirements of voltage control and Mvar reserves which **NGC** may need to take into account for **System** security reasons.
- (b) The form of the submission will be:
- (i) that of a **BM Unit** output or consumption (for MW and for Mvar, in each case a fixed value or an operating range, on the **User System** at the **User System Entry Point**, namely in the case of a **BM Unit** comprising a **Generating Unit** on the higher voltage side of the generator step-up transformer, or in the case of a **Power Park Module**, at the point of connection) required for particular **BM Units** (identified in the submission) connected to that **User System** for each **Settlement Period** of the next **Operational Day**;
  - (ii) adjusted in each case for MW by the conversion factors applicable for those **BM Units** to provide output or consumption at the relevant **Grid Supply Points**.
- (c) At any time and from time to time, between 1000 hours each day and the expiry of the next **Operational Day**, each **Network Operator** must submit to **NGC** in writing any revisions to the information submitted under this BC1.6.1.

#### BC1.6.2 Notification of Times to **Network Operators**

**NGC** will make available indicative **Synchronising** and **De-Synchronising** times to each **Network Operator**, but only relating to **BM Units** comprising a **Generating Unit**, **Power Park Module** or a **CCGT Module Embedded** within that **Network Operator's User System** and those **Gensets** directly connected to the **NGC Transmission System** which **NGC** has identified under **OC2** as being those which may, in the reasonable opinion of **NGC**, affect the integrity of that **User System**. If in preparing for the operation of the **Balancing Mechanism**, **NGC** becomes aware that a **BM Unit** directly connected to the **NGC Transmission System** may, in its reasonable opinion, affect the integrity of that other **User System** which, in the case of a **BM Unit** comprising a **Generating Unit**, **Power Park Module** or a **CCGT Module**, it had not so identified under **OC2**, then **NGC** may make available details of its indicative **Synchronising** and **De-Synchronising** times to that other **User** and shall inform the relevant **BM Participant** that it has done so, identifying the **BM Unit** concerned.

.....

**APPENDIX 1**

**BM UNIT DATA**

.....

**BC1.A.1.7.1** **Power Park Module Matrix** showing the number of each type of **Power Park Units** expected to be available is illustrated in the example form below. The **Power Park Module Matrix** is designed to achieve certainty in knowing the number of **Power Park Units** synchronised to meet the **Physical Notification** and to achieve a **Bid-Offer Acceptance**. The **Power Park Module Matrix** may have as many columns as are required to provide information on the different types of **Power Park Unit** at the **Power Park Module**. The description is required to assist identification of the **Power Park Units** within the **Power Park Module** and correlation with data provided under the **Planning Code**.

**Power Park Module Matrix example form**

<b><u>POWER PARK UNIT AVAILABILITY</u></b>	<b><u>POWER PARK UNITS</u></b>			
	<b><u>Type A</u></b>	<b><u>Type B</u></b>	<b><u>Type C</u></b>	<b><u>Type D</u></b>
<b><u>Description</u></b>				
<b><u>Number of units</u></b>				

**BC1.A.1.7.2** In the absence of the correct submission of a **Power Park Module Matrix** the last submitted (or deemed submitted) **Power Park Module Matrix** shall be taken to be the **Power Park Module Matrix** submitted hereunder.

**BC1.A.1.7.3** **NGC** will rely on the **Power Park Units** specified in such **Power Park Module Matrix** running as indicated in the **Power Park Module Matrix** when it issues an instruction in respect of the **Power Park Module**;

**BC1.A.1.7.4** Subject as provided in PC.A.3.2.4 any changes to the **Power Park Module Matrix** must be notified immediately to **NGC** in accordance with the relevant provisions of **BC1**.

## APPENDIX 2

### DATA TO BE MADE AVAILABLE BY NGC

.....

#### **BC1.A.2.2 Initial Day Ahead Market Information**

Normally by 12:00 hours each day, values (in MW) for each **Settlement Period** of the next following **Operational Day** of the following data items:-

i) Initial National **Indicated Margin**

This is the difference between the sum of **BM Unit** MELs and the forecast of **NGC Demand**.

ii) Initial National **Indicated Imbalance**

This is the difference between the sum of **Physical Notifications** for **BM Units** comprising **Generating Units**, **Power Park Modules** or **CCGT Modules** and the forecast of **NGC Demand**.

iii) Forecast of **NGC Demand**.

#### **BC1.A.2.3 Current Day and Day Ahead Updated Market Information**

Data will normally be made available by the times shown below for the associated periods of time:

<b>Target Data Release Time</b>	<b>Period Start Time</b>	<b>Period End Time</b>
02:00	02:00 D0	05:00 D+1
10:00	10:00 D0	05:00 D+1
16:00	05:00 D+1	05:00 D+2
16:30	16:30 D0	05:00 D+1
22:00	22:00 D0	05:00 D+2

In this table, D0 refers to the current day, D+1 refers to the next day and D+2 refers to the day following D+1.

In all cases, data will be ½ hourly average MW values calculated by **NGC**. Information to be released includes:-

#### National Information

- i) National **Indicated Margin**;
- ii) National **Indicated Imbalance**;
- iii) Updated forecast of **NGC Demand**.

#### Constraint Boundary Information (for each Constraint Boundary)

i) **Indicated Constraint Boundary Margin;**

This is the difference between the Constraint Boundary Transfer limit and the difference between the sum of **BM Unit** MELs and the forecast of local **Demand** within the constraint boundary.

ii) **Local Indicated Imbalance;**

This is the difference between the sum of **Physical Notifications** for **BM Units** comprising **Generating Units**, **Power Park Modules** or **CCGT Modules** and the forecast of local **Demand** within the constraint boundary.

iii) Updated forecast of the local **Demand** within the constraint boundary.

< End of BC1 >

**EXTRACTS FROM BALANCING CODE No 2**

.....

**BC2.5.4      Operation in the absence of instructions from NGC**

In the absence of any **Bid-Offer Acceptances**, **Ancillary Service** instructions issued pursuant to BC2.8 or **Emergency Instructions** issued pursuant to BC2.9:

- (a) as provided for in BC3, each **Synchronised Genset** producing **Active Power** must operate at all times in **Limited Frequency Sensitive Mode** (unless instructed in accordance with BC3.5.4 to operate in **Frequency Sensitive Mode**);
- (b) in the absence of any Mvar **Ancillary Service** instructions, the Mvar output of each **Synchronised Genset** should be 0 Mvar upon **Synchronisation** at the circuit-breaker where the **Genset** is **Synchronised**;
- (c) the excitation system or the voltage control system, unless otherwise agreed with **NGC**, must be operated only in its constant terminal voltage mode of operation with VAR limiters in service, with any constant **Reactive Power** output control mode or constant **Power Factor** output control mode always disabled, unless agreed otherwise with **NGC**. In the event of any change in **System** voltage, a **Generator** must not take any action to override automatic Mvar response which is produced as a result of constant terminal voltage mode of operation of the automatic excitation control system unless instructed otherwise by **NGC** or unless immediate action is necessary to comply with **Stability Limits** or unless constrained by plant operational limits or safety grounds (relating to personnel or plant).
- (d) In the absence of any Mvar **Ancillary Service** instructions, the Mvar output of each **Genset** should be 0 Mvar immediately prior to **De-Synchronisation** at the circuit-breaker where the **Genset** is **Synchronised**, other than in the case of a rapid unplanned **De-Synchronisation**.
- (e) a **Generator** should at all times operate its **CCGT Units** in accordance with the applicable **CCGT Module Matrix**;
- (f) in the case of a **Range CCGT Module**, a **Generator** must operate that **CCGT Module** so that power is provided at the single **Grid Entry Point** identified in the data given pursuant to PC.A.3.2.1 or at the single **Grid Entry Point** to which **NGC** has agreed pursuant to BC1.4.2(f);
- (g) in the event of the **System Frequency** being above 50.3Hz or below 49.7Hz, **BM Participants** must not commence any reasonably avoidable action to regulate the input or output of any **BM Unit** in a manner that could cause the **System Frequency** to deviate further from 50Hz without first using

reasonable endeavours to discuss the proposed actions with **NGC**. **NGC** shall either agree to these changes in input or output or issue a **Bid-Offer Acceptance** in accordance with BC2.7 to delay the change.

(h) a Generator should at all times operate its Power Park Units in accordance with the applicable Power Park Module Matrix.

## BC2.5.5 Commencement or Termination of Participation in the Balancing Mechanism

BC2.5.5.1 In the event that a **BM Participant** in respect of a **BM Unit** with a **Demand Capacity** with a magnitude of less than 50MW or comprising **Generating Units, Power Park Modules** and/or **CCGT Modules** at a **Small Power Station** notifies **NGC** at least 30 days in advance that from a specified **Operational Day** it will:

- (a) no longer submit **Bid-Offer Data** under BC1.4.2(d), then with effect from that **Operational Day** that **BM Participant** no longer has to meet the requirements of BC2.5.1 nor the requirements of CC6.5.8(b) in relation to that **BM Unit**. Also, with effect from that **Operational Day**, any defaulted **Physical Notification** and defaulted **Bid-Offer Data** in relation to that **BM Unit** arising from the **Data Validation, Consistency and Defaulting Rules** will be disregarded and the provisions of BC2.5.2 will not apply;
- (b) submit **Bid-Offer Data** under BC1.4.2(d), then with effect from that **Operational Day** that **BM Participant** will need to meet the requirements of BC2.5.1 and the requirements of CC6.5.8(b) in relation to that **BM Unit**.

BC2.5.5.2 In the event that a **BM Participant** in respect of a **BM Unit** with a **Demand Capacity** with a magnitude of 50MW or greater or comprising **Generating Units, Power Park Modules** and/or **CCGT Modules** at a **Medium Power Station** or **Large Power Station** notifies **NGC** at least 30 days in advance that from a specified **Operational Day** it will:

- (a) no longer submit **Bid-Offer Data** under BC1.4.2(d), then with effect from that **Operational Day** that **BM Participant** no longer has to meet the requirements of CC6.5.8(b) in relation to that **BM Unit**; Also, with effect from that **Operational Day**, any defaulted **Bid-Offer Data** in relation to that **BM Unit** arising from the **Data Validation, Consistency and Defaulting Rules** will be disregarded;
- (b) submit **Bid-Offer Data** under BC1.4.2(d), then with effect from that **Operational Day** that **BM Participant** will need to meet the requirements of CC6.5.8(b) in relation to that **BM Unit**.

.....

BC2.7.5 Additional Action Required from **Generators**

- (a) When complying with **Bid-Offer Acceptances** for a **CCGT Module** a **Generator** will operate its **CCGT Units** in accordance with the applicable **CCGT Module Matrix**.
- (b) When complying with **Bid-Offer Acceptances** for a **CCGT Module** which is a **Range CCGT Module**, a **Generator** must operate that **CCGT Module** so that power is provided at the single **Grid Entry Point** identified in the data given pursuant to PC.A.3.2.1 or at the single **Grid Entry Point** to which **NGC** has agreed pursuant to BC1.4.2 (f).
- (c) On receiving a new MW **Bid-Offer Acceptance**, no tap changing shall be carried out to change the Mvar output unless there is a new Mvar **Ancillary Service** instruction issued pursuant to BC2.8.
- (d) When complying with Bid-Offer Acceptances for a **Power Park Module** a **Generator** will operate its **Power Park Units** in accordance with the applicable **Power Park Module Matrix**.

.....

BC2.9 EMERGENCY CIRCUMSTANCESBC2.9.1 Emergency Actions

BC2.9.1.1 In certain circumstances (as determined by **NGC** in its reasonable opinion) it will be necessary, in order to preserve the integrity of the **NGC Transmission System** and any synchronously connected **External System**, for **NGC** to issue **Emergency Instructions**. In such circumstances, it may be necessary to depart from normal **Balancing Mechanism** operation in accordance with BC2.7 in issuing **Bid-Offer Acceptances**. **BM Participants** must also comply with the requirements of **BC3**.

BC2.9.1.2 Examples of circumstances that may require the issue of **Emergency Instructions** include:-

- (a) **Events** on the **NGC Transmission System** or the **System** of another **User**; or
- (b) the need to maintain adequate **System** and **Localised NRAPM** in accordance with BC2.9.4 below; or
- (c) the need to maintain adequate frequency sensitive **Generating Units Gensets** in accordance with BC2.9.5 below; or
- (d) the need to implement **Demand Control** in accordance with OC6; or

- (e) the need to invoke the **Black Start** process or the **Re-Synchronisation of De-Synchronised Island** process in accordance with OC9.

### BC2.9.3 Examples of Emergency Instructions

BC2.9.3.1 In the case of a **BM Unit**, **Emergency Instructions** may include an instruction for the **BM Unit** to operate in a way that is not consistent with the **Dynamic Parameters**, **QPNs** and/or **Export and Import Limits**.

BC2.9.3.2 In the case of a **Generator**, **Emergency Instructions** may include:

- (a) an instruction to trip one or more **Gensets**; or
- (b) an instruction to trip **Mills** or to **Part Load** a **Generating Unit**; or
- (c) an instruction to **Part Load** a **CCGT Module** or **Power Park Module**; or
- (d) an instruction for the operation of **CCGT Units** within a **CCGT Module** (on the basis of the information contained within the **CCGT Module Matrix**) when emergency circumstances prevail (as determined by **NGC** in **NGC's** reasonable opinion).

(e) an instruction for the operation of **Power Park Units** within a **Power Park Module** (on the basis of the information contained within the **Power Park Module Matrix**) when emergency circumstances prevail (as determined by **NGC** in **NGC's** reasonable opinion).

BC2.9.3.3 Instructions to **Network Operators** relating to the **Operational Day** may include:

- (a) a requirement for **Demand** reduction and disconnection or restoration pursuant to **OC6**;
- (b) an instruction to effect a load transfer between **Grid Supply Points**;
- (c) an instruction to switch in a **System to Demand Intertrip Scheme**;
- (d) an instruction to split a network;
- (e) an instruction to disconnect an item of **Plant** or **Apparatus** from the **System**.

.....

### BC2.11 LIAISON WITH GENERATORS FOR RISK OF TRIP AND AVR TESTING

- BC2.11.1 A **Generator** at the **Control Point** for any of its **Large Power Stations** may request **NGC's** agreement for one of the **Gensets** at that **Power Station** to be operated under a risk of trip. **NGC's** agreement will be dependent on the risk to the **NGC Transmission System** that a trip of the **Genset** would constitute.
- BC2.11.2 (a) Each **Generator** at the **Control Point** for any of its **Large Power Stations** will operate its **Synchronised Gensets** (excluding **Power Park Modules**) with:
- (i) **AVRs** in constant terminal voltage mode with VAR limiters in service at all times. **AVR** constant **Reactive Power** or power factor mode should, if installed, be disabled; and
  - (ii) its generator step-up transformer tap changer selected to manual mode,
- unless released from this obligation in respect of a particular **Genset** by **NGC**.
- (b) Each **Generator** at the **Control Point** for any of its **Large Power Stations** will operate its **Power Park Modules** with a **Completion Date** before **1<sup>st</sup> January 2006** at unity power factor at the **Grid Entry Point** (or **User System Entry Point** if **Embedded**).
- (c) Each **Generator** at the **Control Point** for any of its **Large Power Stations** will operate its **Power Park Modules** with a **Completion Date** on or after **1<sup>st</sup> January 2006** in voltage control mode at the **Grid Entry Point** (or **User System Entry Point** if **Embedded**). **Constant Reactive Power** or power factor mode should, if installed, be disabled.
- (d) Where a power system stabiliser is fitted as part of ~~an~~the excitation system or voltage control system of a **Genset**, it requires on-load commissioning which must be witnessed by **NGC**. Only when the performance of the power system stabiliser has been approved by **NGC** shall it be switched into service by a **Generator** and then it will be kept in service at all times unless otherwise agreed with **NGC**. Further reference is made to this in CC.6.3.8.
- BC2.11.3 A **Generator** at the **Control Point** for any of its **Power Stations** may request **NGC's** agreement for one of its **Gensets** at that **Power Station** to be operated with the **AVR** in manual mode, or power system stabiliser switched out, or VAR limiter switched out. **NGC's** agreement will be dependent on the risk that would be imposed on the **NGC Transmission System** and any **User System**. Provided that in any event a **Generator** may take such action as is reasonably necessary on safety grounds (relating to personnel or plant) .

.....

### Appendix 3 – Submission of Revised Mvar Capability

BC2.A.3.1 For the purpose of submitting revised Mvar data the following terms shall apply:

Full Output	<p><u>in the case of a <b>Synchronous Generating Unit</b> is t</u>The MW output <del>of a <b>Generating Unit</b></del> measured at the generator stator terminals representing the LV equivalent of the <b>Registered Capacity</b> at the <b>Grid Entry Point</b>, <u>and in the case of a <b>Non-synchronous Generating Unit, DC Converter or Power Park Module</b> is the <b>Registered Capacity</b> at the <b>Grid Entry Point</b>.</u></p>
Minimum Output	<p><u>in the case of a <b>Synchronous Generating Unit</b> is t</u>The MW output <del>of a <b>Generating Unit</b></del> measured at the generator stator terminals representing the LV equivalent of the <b>Minimum Generation</b> at the <b>Grid Entry Point</b>, <u>and in the case of a <b>Non-synchronous Generating Unit, DC Converter or Power Park Module</b> is the <b>Minimum Generation</b> at the <b>Grid Entry Point</b>.</u></p>

APPENDIX 3 - ANNEXURE 2

To: NGC National Grid Control Centre

From : [Company Name & Location]

**REVISED Mvar DATA**

NOTIFICATION TIME:

HRS	MINS	DD	MM	YY
.	/	/		

GENERATING UNIT* <u>/POWER PARK MODULE</u> <u>DC CONVERTER</u>	
--	--

Start Time/Date (if not effective immediately)

**REACTIVE POWER CAPABILITY AT SYNCHRONOUS GENERATING UNIT  
GENERATOR STATOR TERMINAL (at rated terminal volts) OR AT THE  
CONNECTION POINT FOR OTHER GENSETS AND DC CONVERTERS**

	MW	LEAD (Mvar)	LAG (Mvar)
<b>AT RATED MW</b>			
AT FULL OUTPUT (MW)			
AT MINIMUM OUTPUT (MW)			

**GENERATING UNIT STEP-UP TRANSFORMER DATA, WHERE APPLICABLE**

TAP CHANGE RANGE (+%,-%)	TAP NUMBER RANGE

**OPTIONAL INFORMATION (for Ancillary Services use only) -  
REACTIVE POWER CAPABILITY AT COMMERCIAL BOUNDARY (at rated stator  
terminal and nominal system volts)**

	LEAD (Mvar)	LAG (Mvar)
<b>AT RATED MW</b>		

Predicted End Time/Date (to be confirmed by redeclaration)

Redeclaration made by (Signature)

\_\_\_\_\_

\* For a CCGT, the redeclaration is for an individual CCGT unit and not the entire module.

< End of BC2 >

## EXTRACTS FROM BALANCING CODE NO.3

BC3.1 INTRODUCTION

BC3.1.1 **BC3** sets out the procedure for **NGC** to use in relation to **Users** to undertake **System Frequency** control. **System Frequency** will be controlled by response from **Gensets (and DC Converters at DC Converter Stations)** operating in **Limited Frequency Sensitive Mode** or **Frequency Sensitive Mode**, by the issuing of instructions to **Gensets (and DC Converters at DC Converter Stations)** and by control of **Demand**. The requirements for **Frequency** control are determined by the consequences and effectiveness of the **Balancing Mechanism**, and accordingly, **BC3** is complementary to **BC1** and **BC2**.

BC3.1.2 Inter-relationship with Ancillary Services

The provision of response (other than by operation in **Limited Frequency Sensitive Mode** or in accordance with BC3.7.1(c)) in order to contribute towards **Frequency** control, as described in **BC3**, by **Generators or DC Converter Station owners** will be an **Ancillary Service**. **Ancillary Services** are divided into three categories, **System Ancillary Services** Parts 1 and 2 and **Commercial Ancillary Services**. **System Ancillary Services**, Parts 1 and 2, are those **Ancillary Services** listed in CC.8.1; those in Part 1 of CC.8.1 are those for which the **Connection Conditions** require the capability as a condition of connection and those in Part 2 are those which may be agreed to be provided by **Users** and which can only be utilised by **NGC** if so agreed. **Commercial Ancillary Services** like those **System Ancillary Services** set out in Part 2 of CC.8.1, may be agreed to be provided by **Users** and which can only be utilised by **NGC** if so agreed.

BC3.1.3 The delivery of **Frequency** control services, if any, from an **External System** via a **DC Converter Station** will be provided for in the **Ancillary Services Agreement** and/or **Bilateral Agreement** with the **DC Converter Station** owner and/or any other relevant agreements with the relevant **EISO**.

BC3.2 OBJECTIVE

The procedure for **NGC** to direct **System Frequency** control is intended to enable (as far as possible) **NGC** to meet the statutory requirements of **System Frequency** control.

BC3.3 SCOPE

**BC3** applies to **NGC** and to **Users**, which in this BC3 means:-

- (a) **Generators** with regard to their **Large Power Stations**,
- (b) **Network Operators**,

- (c) **DC Converter Station owners**
- (d) other providers of **Ancillary Services**, and
- (e) **Externally Interconnected System Operators.**

#### BC3.4 MANAGING SYSTEM FREQUENCY

##### BC3.4.1 Statutory Requirements

When **NGC** determines it is necessary (by having monitored the **System Frequency**), it will, as part of the procedure set out in **BC2**, issue instructions (including instructions for **Commercial Ancillary Services**) in order to seek to regulate **System Frequency** to meet the statutory requirements of **Frequency** control. **Gensets (and DC Converters at DC Converter Stations when transferring Active Power to the Total System)** operating in **Frequency Sensitive Mode** will be instructed by **NGC** to operate taking due account of the **Target Frequency** notified by **NGC**.

#### BC3.5 RESPONSE FROM GENSETS (AND DC CONVERTERS AT DC CONVERTER STATIONS WHEN TRANSFERRING ACTIVE POWER TO THE TOTAL SYSTEM)

##### BC3.5.1 Capability

Each **Genset (and each DC Converter at a DC Converter Station)** must at all times have the capability to operate automatically so as to provide response to changes in **Frequency** in accordance with the requirements of CC.6.3.6 and CC.6.3.7 in order to contribute to containing and correcting the **System Frequency** within the statutory requirements of **Frequency** control. For **DC Converters at DC Converter Stations, BC.3.1.3 also applies.** In addition each **Genset (and each DC Converter at a DC Converter Station)** must at all times have the capability to operate in a **Limited Frequency Sensitive Mode** by operating so as to provide **Limited High Frequency Response**.

## .2 **Limited Frequency Sensitive Mode**

Each **Synchronised Genset** producing **Active Power (and each DC Converter at a DC Converter Station)** must operate at all times in a **Limited Frequency Sensitive Mode** (unless instructed in accordance with BC3.5.4 below to operate in **Frequency Sensitive Mode**). Operation in **Limited Frequency Sensitive Mode** must achieve the capability requirement described in CC.6.3.3 for **System Frequencies** up to 50.4Hz and shall be deemed not to be in contravention of CC.6.3.7.

- BC3.5.3 (a)** Existing Gas Cooled Reactor Plant  
**NGC** will permit **Existing Gas Cooled Reactor Plant** other than **Frequency Sensitive AGR Units** to operate in **Limited Frequency Sensitive Mode** at all times.

- (b) **Power Park Modules with Completion Dates before 1 January 2006**  
NGC will permit Power Park Modules with Completion Dates before 1 January 2006 to operate in Limited Frequency Sensitive Mode at all times.

.4

#### Frequency Sensitive Mode

- (a) **NGC** may issue an instruction to a **Genset** (or DC Converter at a DC Converter Station if agreed as described in BC.3.1.3) to operate so as to provide **Primary Response** and/or **Secondary Response** and/or **High Frequency Response** (in the combinations agreed in the relevant **Ancillary Services Agreement**). When so instructed, the **Genset or DC Converter at a DC Converter Station** must operate in accordance with the instruction and will no longer be operating in **Limited Frequency Sensitive Mode**, but by being so instructed will be operating in **Frequency Sensitive Mode**.
- (b) **Frequency Sensitive Mode** is the generic description for a **Genset** (or DC Converter at a DC Converter Station) operating in accordance with an instruction to operate so as to provide **Primary Response** and/or **Secondary Response** and/or **High Frequency Response** (in the combinations agreed in the relevant **Ancillary Services Agreement**).
- (c) The magnitude of the response in each of those categories instructed will be in accordance with the relevant **Ancillary Services Agreement** with the **Generator or DC Converter Station owner**.
- (d) Such instruction will continue until countermanded by NGC or until;
- (i) the **Genset** is **De-Synchronised**, or;
  - (ii) the **DC Converter** ceases to transfer **Active Power** to or from the **Total System** subject to the conditions of any relevant agreement relating to the operation of the **DC Converter Station**,
- whichever is the first to occur.
- (e) NGC will not so instruct **Generators** in respect of **Existing Gas Cooled Reactor Plant** other than **Frequency Sensitive AGR Units**.

BC3.5.5

#### System Frequency Induced Change

A **System Frequency** induced change in the **Active Power** output of a **Genset** (or DC Converter at a DC Converter Station) which assists recovery to **Target Frequency** must not be countermanded by a **Generator or DC Converter Station owner** except where it is done purely on safety grounds (relating to either personnel or plant) or, where necessary, to ensure the integrity of the **Power Station or DC Converter Station**.

BC3.6 RESPONSE TO LOW FREQUENCYBC3.6.1 Low Frequency Relay Initiated Response from **Gensets and (DC Converters at DC Converter Stations)**

- (a) **NGC** may utilise **Gensets** (and **DC Converters at DC Converter Stations**) with the capability of **Low Frequency Relay** initiated response as:
- (i) synchronisation and generation from standstill;
  - (ii) generation from zero generated output;
  - (iii) increase in generated output;
  - (iv) increase in **DC Converter** output to the **Total System** (if so agreed as described in BC3.1.3);
  - (v) decrease in **DC Converter** input from the **Total System** (if so agreed as described in BC3.1.3);

in establishing its requirements for **Operating Reserve**.

- (b) (i) **NGC** will specify within the range agreed with **Generators** and/or **EISOs** and/or **DC Converter Station** owners (if so agreed as described in BC3.1.3), **Low Frequency Relay** settings to be applied to ~~the~~ **Gensets or DC Converters at DC Converter Stations** pursuant to BC3.6.1 (a) and instruct the **Low Frequency Relay** initiated response placed in and out of service.
- (ii) **Generators** and/or **EISOs** and/or **DC Converter Station** owners (if so agreed as described in BC3.1.3) will comply with **NGC** instructions for **Low Frequency Relay** settings and **Low Frequency Relay** initiated response to be placed in or out of service. **Generators** or **DC Converter Station** owners or **EISO** may not alter such **Low Frequency Relay** settings or take **Low Frequency Relay** initiated response out of service without **NGC's** agreement (such agreement not to be unreasonably withheld or delayed), except for safety reasons.

BC3.6.2 Low Frequency Relay Initiated Response from **Demand** and other **Demand** modification arrangements (which may include a **DC Converter Station** when importing **Active Power** from the **Total System**)

- (a) **NGC** may, pursuant to an **Ancillary Services Agreement**, utilise **Demand** with the capability of **Low Frequency Relay** initiated **Demand** reduction in establishing its requirements for **Frequency Control**.

- (b) (i) **NGC** will specify within the range agreed the **Low Frequency Relay** settings to be applied pursuant to BC3.6.2 (a), the amount of **Demand** reduction to be available and will instruct the **Low Frequency Relay** initiated response to be placed in or out of service.
  - (ii) **Users** will comply with **NGC** instructions for **Low Frequency Relay** settings and **Low Frequency Relay** initiated **Demand** reduction to be placed in or out of service. **Users** may not alter such **Low Frequency Relay** settings or take **Low Frequency Relay** initiated response out of service without **NGC's** agreement, except for safety reasons.
  - (iii) In the case of any such **Demand** which is **Embedded**, **NGC** will notify the relevant **Network Operator** of the location of the **Demand**, the amount of **Demand** reduction to be available, and the **Low Frequency Relay** settings.
- (c) **NGC** may also utilise other **Demand** modification arrangements pursuant to an agreement for **Ancillary Services**, in order to contribute towards **Operating Reserve**.

BC3.7 RESPONSE TO HIGH FREQUENCY REQUIRED FROM SYNCHRONISED GENSETS (AND DC CONVERTERS AT DC CONVERTER STATIONS WHEN TRANSFERRING ACTIVE POWER TO THE TOTAL SYSTEM)

BC3.7.1 Plant in Frequency Sensitive Mode instructed to provide High Frequency Response

- (a) Each **Synchronised Genset** (or each DC Converter at a DC Converter Station) in respect of which the **Generator** or DC Converter Station owner and/or EISO has been instructed to operate so as to provide **High Frequency Response**, which is producing **Active Power** and which is operating above **Designed Minimum Operating Level**, is required to reduce **Active Power** output in response to an increase in **System Frequency** above the **Target Frequency** (or such other level of **Frequency** as may have been agreed in an **Ancillary Services Agreement**). The **Target Frequency** is normally 50.00 Hz except where modified as specified under BC3.4.2.
- (b) (i) The rate of change of **Active Power** output with respect to **Frequency** up to 50.5 Hz shall be in accordance with the provisions of the relevant **Ancillary Services Agreement** with each **Generator** or DC Converter Station owner. If more than one rate is provided for in the **Ancillary Services Agreement** **NGC** will instruct the rate when the instruction to operate to provide **High Frequency Response** is given.

- (ii) The reduction in **Active Power** output by the amount provided for in the relevant **Ancillary Services Agreement** must be fully achieved within 10 seconds of the time of the **Frequency** increase and must be sustained at no lesser reduction thereafter.
  - (iii) It is accepted that the reduction in **Active Power** output may not be to below the **Designed Minimum Operating Level**.
- (c) In addition to the **High Frequency Response** provided, the **Genset (or DC Converter at a DC Converter Station)** must continue to reduce **Active Power** output in response to an increase in **System Frequency** to 50.5 Hz or above at a minimum rate of 2 per cent of output per 0.1 Hz deviation of **System Frequency** above that level, such reduction to be achieved within five minutes of the rise to or above 50.5 Hz. For the avoidance of doubt, the provision of this reduction in **Active Power** output is not an **Ancillary Service**.

## BC3.7.2

Plant in **Limited Frequency Sensitive Mode**

- (a) Each **Synchronised Genset (or DC Converter at a DC Converter Station)** operating in a **Limited Frequency Sensitive Mode** which is producing **Active Power** is also required to reduce **Active Power** output in response to **System Frequency** when this rises above 50.4 Hz. In the case of DC Converters at DC Converter Stations, the provisions of BC.3.7.7 are also applicable. For the avoidance of doubt, the provision of this reduction in **Active Power** output is not an **Ancillary Service**. Such provision is known as "**Limited High Frequency Response**".
- (b) (i) The rate of change of **Active Power** output must be at a minimum rate of 2 per cent of output per 0.1 Hz deviation of **System Frequency** above 50.4 Hz.
- (ii) The reduction in **Active Power** output must be continuously and linearly proportional, as far as is practicable, to the excess of **Frequency** above 50.4 Hz and must be provided increasingly with time over the period specified in (iii) below.
- (iii) As much as possible of the proportional reduction in **Active Power** output must result from the frequency control device (or speed governor) action and must be achieved within 10 seconds of the time of the **Frequency** increase above 50.4 Hz.
- (iv) The residue of the proportional reduction in **Active Power** output which results from automatic action of the **Genset (or DC Converter at a DC Converter Station)** output control devices other than the frequency control devices (or speed governors) must be achieved within 3 minutes from the time of the **Frequency** increase above 50.4 Hz.

- (v) Any further residue of the proportional reduction which results from non-automatic action initiated by the **Generator or DC Converter Station owner** shall be initiated within 2 minutes, and achieved within 5 minutes, of the time of the **Frequency** increase above 50.4 Hz.
- (c) Each **Genset (or DC Converter at a DC Converter Station)** which is providing **Limited High Frequency Response** in accordance with this BC3.7.2 must continue to provide it until the **Frequency** has returned to or below 50.4 Hz or until otherwise instructed by **NGC**.

## BC3.7.3

Plant operation to below **Minimum Generation**

- (a) As stated in CC.A.3.2, steady state operation below **Minimum Generation** is not expected but if **System** operating conditions cause operation below **Minimum Generation** which give rise to operational difficulties for the **Genset (or DC Converter at a DC Converter Station)** then **NGC** should not, upon request, unreasonably withhold issuing a **Bid-Offer Acceptance** to return the **Generating Unit, Power Park Module, DC Converter** or **CCGT Module** to an output not less than **Minimum Generation**. In the case of a **DC Converter** not participating in the **Balancing Mechanism**, then **NGC** will, upon request, attempt to return the **DC Converter** to an output not less than **Minimum Generation** or to zero transfer or to reverse the transfer of **Active Power**.
- (b) It is possible that a **Synchronised Genset (or a DC Converter at a DC Converter Station)** which has responded as required under BC3.7.1 or BC3.7.2 to an excess of **System Frequency**, as therein described, will (if the output reduction is large or if the **Genset (or DC Converter at the DC Converter Station)** output has reduced to below the **Designed Minimum Operating Level**) trip after a time.
- (c) All reasonable efforts should in the event be made by the **Generator or DC Converter Station owner** to avoid such tripping, provided that the **System Frequency** is below 52Hz.
- (d) If the **System Frequency** is at or above 52Hz, the requirement to make all reasonable efforts to avoid tripping does not apply and the **Generator or DC Converter Station owner** is required to take action to protect the **Generating Units, Power Park Modules or DC Converters** as specified in CC.6.3.13.
- (e) In the event of the **System Frequency** becoming stable above 50.5Hz, after all **Genset and DC Converter** action as specified in BC3.7.1 and BC3.7.2 has taken place, **NGC** will issue appropriate **Bid-Offer Acceptances** and/or **Ancillary Service** instructions, which may include **Emergency Instructions** under **BC2** to trip **Gensets (or, in the case of DC Converters at DC Converter Stations, to stop or reverse the transfer of Active**

**Power**) so that the **Frequency** returns to below 50.5Hz and ultimately to **Target Frequency**.

- (f) If the **System Frequency** has become stable above 52 Hz, after all **Genset and DC Converter** action as specified in BC3.7.1 and BC3.7.2 has taken place, **NGC** will issue **Emergency Instructions** under **BC2** to trip appropriate **Gensets** (or in the case of **DC Converters** at **DC Converter Stations** to stop or reverse the transfer of **Active Power**) to bring the **System Frequency** to below 52Hz and follow this with appropriate **Bid- Offer Acceptances** or **Ancillary Service** instructions or further **Emergency Instructions** under **BC2** to return the **System Frequency** to below 50.5 Hz and ultimately to **Target Frequency**.

BC3.7.4 The **Generator or DC Converter Station owner** will not be in breach of any of the provisions of BC2 by following the provisions of BC3.7.1, BC3.7.2 or BC3.7.3.

BC3.7.5 Information update to **NGC**  
In order that **NGC** can deal with the emergency conditions effectively, it needs as much up to date information as possible and accordingly **NGC** must be informed of the action taken in accordance with BC3.7.1(c) and BC3.7.2 as soon as possible and in any event within 7 minutes of the rise in **System Frequency**, directly by telephone from the **Control Point** for the **Power Station or DC Converter Station**.

BC3.7.6 (a) Existing Gas Cooled Reactor Plant  
For the avoidance of doubt, **Generating Units** within **Existing Gas Cooled Reactor Plant** are required to comply with the applicable provisions of this BC3.7 (which, for the avoidance of doubt, other than for **Frequency Sensitive AGR Units**, do not include BC3.7.1).

(b) Power Park Modules with Completion Dates before 1 January 2006  
For the avoidance of doubt, **Power Park Modules with Completion Dates before 1 January 2006** are required to comply with the applicable provisions of this BC3.7 (which, for the avoidance of doubt do not include BC3.7.1).

**Extracts from Data Registration Code**DRC.3            SCOPEDRC.3.1            The **DRC** applies to **NGC** and to **Users**, which in this **DRC** means:-

- (a)        **Generators;**
- (b)        **Network Operators;**
- (c)        **DC Converter Station owners**
- (d)        **Suppliers;**
- (e)        **Non-Embedded Customers** (including, for the avoidance of doubt, a **Pumped Storage Generator** in that capacity);
- (f)        **Externally Interconnected System Operators;**
- (g)        **Interconnector Users;** and
- (h)        **BM Participants.**

.....

DRC.6            **DATA TO BE REGISTERED**

DRC.6.1            Schedules 1 to 14 attached cover the following data areas.

DRC.6.1.1        **SCHEDULE 1 - GENERATING UNIT (OR CCGT Module ), Power Park Module and DC Converter TECHNICAL DATA.**Comprising **Generating Unit** (and **CCGT Module**) fixed electrical parameters.DRC.6.1.2        **SCHEDULE 2 - GENERATION PLANNING PARAMETERS**Comprising the **Genset** parameters required for **Operational Planning** studies.DRC.6.1.3        **SCHEDULE 3 - LARGE POWER STATION OUTAGE PROGRAMMES, OUTPUT USABLE AND INFLEXIBILITY INFORMATION.**Comprising generation outage planning, **Output Usable** and inflexibility information at timescales down to the daily **BM Unit Data** submission.DRC.6.1.4        **SCHEDULE 4 - LARGE POWER STATION Droop and Response data.**Comprising data on Governor droop settings, and **Primary, Secondary and High Frequency Response** data for **Large Power Stations and DC Converter Stations.**

- DRC.6.1.5      SCHEDULE 5 - **USER'S SYSTEM DATA.**
- Comprising electrical parameters relating to **Plant** and **Apparatus** connected to the **NGC Transmission System.**
- DRC.6.1.6      SCHEDULE 6 - **USERS OUTAGE INFORMATION.**
- Comprising the information required by **NGC** for outages on the **Users System**, including outages at **Power Stations** other than outages of **Gensets**
- DRC.6.1.7      SCHEDULE 7 - **LOAD CHARACTERISTICS.**
- Comprising the estimated parameters of load groups in respect of, for example, harmonic content and response to frequency.
- DRC.6.1.8      SCHEDULE 8 - **BM UNIT DATA.**
- DRC.6.1.9      SCHEDULE 9 - **DATA SUPPLIED BY NGC TO USERS.**
- DRC.6.1.10     SCHEDULE 10 - **USER'S DEMAND PROFILES AND ACTIVE ENERGY DATA**
- Comprising information relating to the **User's** total **Demand** and **Active Energy** taken from the **NGC Transmission System**
- DRC.6.1.11     SCHEDULE 11 - **CONNECTION POINT DATA**
- Comprising information relating to **Demand**, demand transfer capability and a summary of the **Small Power Station, Medium Power Station** and **Customer** generation connected to the **Connection Point**
- DRC.6.1.12     SCHEDULE 12 - **DEMAND CONTROL DATA**
- Comprising information related to **Demand Control**
- DRC.6.1.13     SCHEDULE 13 - **FAULT INFEEED DATA**
- Comprising information relating to the Short Circuit contribution to the **NGC Transmission System** from **Users** other than **Generators.**
- DRC.6.1.14     SCHEDULE 14 - **FAULT INFEEED DATA**
- Comprising information relating to the Short Circuit contribution to the **NGC Transmission System** from **Generators** and DC Converter Station owners.

DRC.6.2 The **Schedules** applicable to each class of **User** are as follows:

<b>Generators with Large Power Stations</b>	Sched 1, 2, 3, 4, 9, 14
<b>Generators with Medium Power Stations</b> (See note 2)	Sched 1, 9, 14
<b>Generators with Small Power Stations</b> directly connected to the <b>NGC Transmission System</b>	Sched 1, 6, 14
All <b>Users</b> connected directly to <b>NGC Transmission System</b>	Sched 5, 6, 9
All <b>Users</b> connected directly to the <b>NGC Transmission System</b> other than <b>Generators</b>	Sched 10,11,13
All <b>Users</b> connected directly to <b>NGC Transmission System</b> with <b>Demand</b>	Sched 7, 9
<b>A Pumped Storage Generator, Externally Interconnected System Operator and Interconnector Users</b>	Sched12 (as marked)
All <b>Suppliers</b>	Sched 12
All <b>Network Operators</b>	Sched 12
All <b>BM Participants</b>	Sched 8
<u>All <b>DC Converter Station</b> owners</u>	<u>Sched 1, 4, 9, 14</u>

DATA DESCRIPTION	UNITS	DATA CAT.	POWER PARK UNIT (OR POWER PARK MODULE, AS THE CASE MAY BE)						
			G1	G2	G3	G4	G5	G6	STM
<u>Power Park Module Rated MVA</u> <u>Power Park Module Rated MW</u> *Performance Chart at <b>Power Park Module</b> connection point * <b>Output Usable</b> (on a monthly basis)	MVA MW MW	SPD+ SPD+ SPD	(see <b>OC2</b> for specification)						
<b>Power Park Unit Data</b> <u>Rated MVA</u> <u>Rated MW</u> <u>Rated terminal voltage</u> <u>Inertia constant</u> <u>Stator Resistance.</u> <u>Stator Reactance.</u> <u>Magnetising Reactance</u> <u>Rotor Resistance.</u> <u>Rotor Reactance.</u> <u>The optimum rotor power coefficient (C<sub>p</sub>) versus tip speed ratio curve</u> <u>The electrical power versus rotor speed for a range of wind speeds. Where applicable a transfer function block diagram including parameters of the torque speed controller.</u> Note: Rotor resistance and reactance values should be given for both starting and running conditions.	MVA MW V MW secs /MVA % on MVA % on MVA % on MVA % on MVA % on MVA Diagram Diagram	SPD+ SPD+ SPD+ SPD+ DPD SPD+ SPD+ SPD+ SPD+ SPD+ DPD DPD							
<u>For Doubly Fed Induction Generators the following Power Park Unit information is also required:</u>  <u>Rotor speed range</u> <u>Power Converter Rating</u>  <b>Transfer function block diagram, parameters and description of the operation of the power electronic converter including the torque speed controller</b>	Diagram pu MVA  Diagram	DPD SPD+ SPD+  DPD							

<u>DATA DESCRIPTION</u>	<u>UNITS</u>	<u>DATA CAT.</u>	<u>POWER PARK UNIT (OR POWER PARK MODULE, AS THE CASE MAY BE)</u>						
			<u>G1</u>	<u>G2</u>	<u>G3</u>	<u>G4</u>	<u>G5</u>	<u>G6</u>	<u>STM</u>
<p><u>For a <b>Power Park Unit</b> consisting of a synchronous machine in combination with a back to back AC/DC/AC converter the information should be given in accordance with the applicable sections of PC.A.5.4.3.1 and PC.A.5.4.3.2. The following information is also required :</u></p>									
<u>Inertia constant</u>	<u>MW secs /MVA</u>	<u>DPD</u>							
<u>Symmetrical three phase short-circuit current infeed after the subtransient contribution has significantly decayed at the machine side of the converter</u>	<u>kA</u>	<u>DPD</u>							



**DC CONVERTER STATION TECHNICAL DATA**

DC CONVERTER STATION NAME

DATE: \_\_\_\_\_

<u>Data Description</u>	<u>Units</u>	<u>Data Category</u>	<u>DC Converter Station Data</u>
<b>DC CONVERTER STATION DEMANDS:</b>			
<b><u>Demand supplied through Station Transformers associated with the DC Converter Station [PC.A.4.1]</u></b>			
<u>- Demand with all DC Converters operating at Rated MW import.</u>	MW Mvar	DPD DPD	
<u>- Demand with all DC Converters operating at Rated MW export.</u>	MW Mvar	DPD DPD	
<b><u>Additional Demand associated with the DC Converter Station supplied through the NGC Transmission System. [PC.A.4.1]</u></b>			
<u>- The maximum Demand that could occur.</u>	MW Mvar	DPD DPD	
<u>- Demand at specified time of annual peak half hour of NGC Demand at Annual ACS Conditions.</u>	MW Mvar	DPD DPD	
<u>- Demand at specified time of annual minimum half-hour of NGC Demand.</u>	MW Mvar	DPD DPD	
<b><u>DC CONVERTER STATION DATA</u></b>			
<u>Number of poles, i.e. number of DC Converters</u>	Text	SPD+	
<u>Pole arrangement (e.g. monopole or bipole)</u>	Text	SPD+	
<u>Details of each viable operating configuration</u>		SPD+	
<u>Configuration 1</u>			
<u>Configuration 2</u>	Diagram		
<u>Configuration 3</u>	Diagram		
<u>Configuration 4</u>	Diagram		
<u>Configuration 5</u>	Diagram		
<u>Configuration 6</u>	Diagram		
<u>Remote ac connection arrangement</u>	Diagram	SPD	

Data Description	Units	Data Category	Operating Configuration					
			1	2	3	4	5	6
<b><u>DC CONVERTER STATION DATA</u></b>								
<u>Point of connection to the <b>NGC Transmission System</b> (or the <b>Total System</b> if embedded) of the <b>DC Converter Station</b> configuration in terms of geographical and electrical location and system voltage</u>	<u>Text</u>	<b><u>SPD</u></b>						
<u>If the busbars at the <b>Connection Point</b> are normally run in separate sections identify the section to which the <b>DC Converter Station</b> configuration is connected</u>	<u>Section Number</u>	<b><u>SPD</u></b>						
<u><b>Rated MW</b> import per pole <b>[PC.A.3.3.1]</b></u>	<u>MW</u>	<b><u>SPD+</u></b>						
<u><b>Rated MW</b> export per pole <b>[PC.A.3.3.1]</b></u>	<u>MW</u>	<b><u>SPD+</u></b>						
<b><u>ACTIVE POWER TRANSFER CAPABILITY (PC.A.3.2.2)</u></b>								
<u><b>Registered Capacity</b></u>	<u>MW</u>	<b><u>SPD</u></b>						
<u><b>Registered Import Capacity</b></u>	<u>MW</u>	<b><u>SPD</u></b>						
<u><b>Minimum Generation</b></u>	<u>MW</u>	<b><u>SPD</u></b>						
<u><b>Minimum Import Capacity</b></u>	<u>MW</u>	<b><u>SPD</u></b>						
<u>Import MW available in excess of <b>Registered Import Capacity</b>.</u>	<u>MW</u>	<b><u>SPD</u></b>						
<u>Time duration for which MW in excess of <b>Registered Import Capacity</b> is available</u>	<u>min</u>	<b><u>SPD</u></b>						
<u>Export MW available in excess of <b>Registered Capacity</b>.</u>	<u>MW</u>	<b><u>SPD</u></b>						
<u>Time duration for which MW in excess of <b>Registered Capacity</b> is available</u>	<u>min</u>	<b><u>SPD</u></b>						
<b><u>DC CONVERTER TRANSFORMER [PC.A.5.4.3.1]</u></b>								
<u>Rated MVA</u>	<u>MVA</u>	<b><u>DPD</u></b>						
<u>Winding arrangement</u>								
<u>Nominal primary voltage</u>	<u>kV</u>	<b><u>DPD</u></b>						
<u>Nominal secondary (converter-side) voltage(s)</u>	<u>kV</u>	<b><u>DPD</u></b>						
<u>Positive sequence reactance</u>								
<u>Maximum tap</u>	<u>% on MVA</u>	<b><u>DPD</u></b>						
<u>Nominal tap</u>	<u>% on MVA</u>	<b><u>DPD</u></b>						
<u>Minimum tap</u>	<u>% on MVA</u>	<b><u>DPD</u></b>						
<u>Positive sequence resistance</u>								
<u>Maximum tap</u>	<u>% on MVA</u>	<b><u>DPD</u></b>						
<u>Nominal tap</u>	<u>% on MVA</u>	<b><u>DPD</u></b>						
<u>Minimum tap</u>	<u>% on MVA</u>	<b><u>DPD</u></b>						
<u>Zero phase sequence reactance</u>	<u>% on MVA</u>	<b><u>DPD</u></b>						
<u>Tap change range</u>	<u>+%/-%</u>	<b><u>DPD</u></b>						
<u>Number of steps</u>		<b><u>DPD</u></b>						

<u>Data Description</u>	<u>Units</u>	<u>Data Category</u>	<u>Operating configuration</u>					
			<u>1</u>	<u>2</u>	<u>3</u>	<u>4</u>	<u>5</u>	<u>6</u>
<p><b><u>DC NETWORK [PC.A.5.4.3.1 (c)]</u></b></p> <p><u>Rated DC voltage per pole</u> <u>Rated DC current</u></p> <p><u>Details of the DC Network described in diagram form including resistance, inductance and capacitance of all DC cables and/or DC lines. Details of any line reactors (including line reactor resistance), line capacitors, DC filters, earthing electrodes and other conductors that form part of the DC Network should be shown.</u></p>	<p>kV A</p> <p>Diagram</p>	<p>DPD DPD DPD</p>						
<p><b><u>DC CONVERTER STATION AC HARMONIC FILTER AND REACTIVE COMPENSATION EQUIPMENT [PC.A.5.4.3.1 (d)]</u></b></p> <p><u>For all switched reactive compensation equipment</u></p> <p><u>Diagram of filter connections</u> <u>Type of equipment (e.g. fixed or variable)</u> <u>Capacitive rating; or</u> <u>Inductive rating; or</u> <u>Operating range</u></p> <p><u>Reactive Power consumption as a function of various MW transfer levels</u></p>	<p>Text Mvar Mvar Mvar</p> <p>Table</p>	<p>SPD DPD DPD DPD DPD</p>						

<u>Data Description</u>	<u>Units</u>	<u>Data Category</u>	<u>Operating configuration</u>					
			1	2	3	4	5	6
<b>CONTROL SYSTEMS [PC.A.5.4.3.2]</b>								
<u>Static <math>V_{DC} - P_{DC}</math> (DC voltage – DC power) or</u> <u>Static <math>V_{DC} - I_{DC}</math> (DC voltage – DC current)</u> <u>characteristic (as appropriate) when operating as</u> <u>–Rectifier</u> <u>–Inverter</u>	Diagram Diagram	DPD DPD						
<u>Details of rectifier mode control system,</u> <u>in block diagram form together with parameters</u> <u>showing transfer functions of individual elements.</u>	Diagram	DPD						
<u>Details of inverter mode control system,</u> <u>in block diagram form showing transfer functions</u> <u>of individual elements including parameters.</u>	Diagram	DPD						
<u>Details of converter transformer tap changer control</u> <u>system in block diagram form showing transfer</u> <u>functions of individual elements including</u> <u>parameters. (Only required for DC converters</u> <u>connected to the NGC system.)</u>	Diagram	DPD						
<u>Details of AC filter and reactive compensation</u> <u>equipment control systems in block diagram form</u> <u>showing transfer functions of individual elements</u> <u>including parameters. (Only required for DC</u> <u>converters connected to the NGC system.)</u>	Diagram	DPD						
<u>Details of any frequency and/or load control systems in</u> <u>block diagram form showing transfer functions of</u> <u>individual elements including parameters.</u>	Diagram	DPD						
<u>Details of any large or small signal modulating controls,</u> <u>such as power oscillation damping controls or sub-</u> <u>synchronous oscillation damping controls, that</u> <u>have not been submitted as part of the above</u> <u>control system data.</u>	Diagram	DPD						
<b>LOADING PARAMETERS [PC.A.5.4.3.3]</b>								
<u>MW</u> <u>Export</u> <u>Nominal loading rate</u> <u>Maximum (emergency) loading rate</u>	MW/s MW/s	DPD DPD						
<u>MW</u> <u>Import</u> <u>Nominal loading rate</u> <u>Maximum (emergency) loading rate</u>	MW/s MW/s	DPD DPD						
<u>Maximum recovery time, to 90% of pre-fault loading,</u> <u>following an AC system fault or severe voltage</u> <u>depression.</u>	s	DPD						
<u>Maximum recovery time, to 90% of pre-fault loading,</u> <u>following a transient DC Network fault.</u>	s	DPD						

DATA REGISTRATION CODE

**GENERATION PLANNING PARAMETERS**

This schedule contains the **Genset Generation Planning Parameters** required by **NGC** to facilitate studies in **Operational Planning** timescales.

For a **Generating Unit** (other than a **Power Park Unit**) at a **Large Power Station** the information is to be submitted on a unit basis and for a **CCGT Module** or **Power Park Module** at a **Large Power Station** the information is to be submitted on a module basis, unless otherwise stated.

Where references to **CCGT Modules** or **Power Park Module** at a **Large Power Station** are made, the columns "G1" etc should be amended to read "M1" etc, as appropriate.

**Power Station:** \_\_\_\_\_

**Generation Planning Parameters**

DATA DESCRIPTION	UNITS	DATA CAT.	GENSET OR STATION DATA						
			G1	G2	G3	G4	G5	G6	STN
<u>OUTPUT CAPABILITY</u>									
<b>Registered Capacity</b> on a station and unit basis (on a station and module basis in the case of a <b>CCGT Module</b> <u>or <b>Power Park Module</b></u> at a <b>Large Power Station</b> )	MW	SPD							
<b>Minimum Generation</b> (on a module basis in the case of a <b>CCGT Module</b> <u>or <b>Power Park Module</b></u> at a <b>Large Power Station</b> )	MW	SPD							
MW available from <b>Generating Units</b> <u>or <b>Power Park Module</b></u> in excess of <b>Registered Capacity</b>	MW	SPD							
<u>REGIME UNAVAILABILITY</u>									

Page 3

DATA DESCRIPTION	UNITS	DATA CAT.	GENSET OR STATION DATA						
			G1	G2	G3	G4	G5	G6	STN
<b>CCGT MODULE PLANNING MATRIX</b>		OC2	(please attach)						
<b>POWER PARK MODULE PLANNING MATRIX</b>		OC2	(please attach)						
<b>Power Park Module Active Power Output/ Intermittent Power Source Curve (eg MW output / Wind speed)</b>		OC2	(please attach)						

**DATA REGISTRATION CODE**

**SCHEDULE 3**  
Page 1 of 3

**LARGE POWER STATION OUTAGE PROGRAMMES, OUTPUT USABLE AND INFLEXIBILITY INFORMATION**

(Also outline information on contracts involving **External Interconnections**)

For a **Generating Unit at a Large Power Station** the information is to be submitted on a unit basis and for a **CCGT Module or Power Park Module** at a **Large Power Station** the information is to be submitted on a module basis, unless otherwise stated

DATA DESCRIPTION		UNITS	TIME COVERED	UPDATE TIME	DATA CAT.
<b>Power Station name:</b> ..... <b>Generating Unit</b> (or <b>CCGT Module</b> or <b>Power Park Module</b> at a <b>Large Power Station</b> ) <b>number:</b> ... <b>Registered Capacity:</b> .....					
<b>Large Power Station OUTAGE PROGRAMME</b>	<b>Large Power Station OUTPUT USABLE</b>				
<u>PLANNING FOR YEARS 3 - 7 AHEAD</u>					

**SCHEDULE 3**  
Page 2 of 3

**DATA REGISTRATION CODE**

**GOVERNOR DROOP AND RESPONSE**

The Data in this Schedule 4 is to be supplied by **Generators** with respect to all **Large Power Stations** and by **DC Converter Station owners** (where agreed), whether directly connected or **Embedded**

DATA DESCRIPTION	NORMAL VALUE	M W	DAT A CAT	DROOP%			RESPONSE CAPABILITY			
				Unit 1	Unit 2	Unit 3	Primary	Secondary	High Frequency	
MLP1	<b>Designed Minimum Operating Level</b> (for a <b>CCGT Module or Power Park Module</b> , on a modular basis assuming all units are <b>Synchronised</b> )									
MLP2	<b>Minimum Generation</b> (for a <b>CCGT Module or Power Park Module</b> , on a modular basis assuming all units are <b>Synchronised</b> )									
MLP3	70% of <b>Registered Capacity</b>									
MLP4	80% of <b>Registered Capacity</b>									
MLP5	95% of <b>Registered Capacity</b>									
MLP6	<b>Registered Capacity</b>									

Notes:

1. The data provided in this Schedule 4 is not intended to constrain any **Ancillary Services Agreement**.
2. **Registered Capacity** should be identical to that provided in Schedule 2.
3. The Governor Droop should be provided for each **Generating Unit** (excluding **Power Park Units**), **Power Park Module** or **DC Converter**. The Response Capability should be provided for each **Genset** or **DC Converter**.
4. **Primary**, **Secondary** and **High Frequency Response** are defined in CC.A.3.2 and are based on a frequency ramp of 0.5Hz over 10 seconds. **Primary Response** is the minimum value of response between 10s and 30s after the frequency ramp starts, **Secondary Response** between 30s and 30 minutes, and **High Frequency Response** is the minimum value after 10s on an indefinite basis.
5. For plants which have not yet **Synchronised**, the data values of MLP1 to MLP6 should be as described above. For plants which have already **Synchronised**, the values of MLP1 to MLP6 can take any value between **Designed Operating Minimum Level** and **Registered Capacity**. If MLP1 is not provided at the **Designed Minimum Operating Level**, the value of the **Designed Minimum Operating Level** should be separately stated.

**USERS SYSTEM DATA**

DATA DESCRIPTION	UNITS	DATA CATEGORY
<b><u>PROTECTION SYSTEMS</u></b>		
The following information relates only to <b>Protection</b> equipment which can trip or inter-trip or close any <b>Connection Point</b> circuit breaker or any <b>NGC</b> circuit breaker. The information need only be supplied once, in accordance with the timing requirements set out in PC.A.1.4 (b) and need not be supplied on a routine annual thereafter, although <b>NGC</b> should be notified if any of the information changes.		
(a) A full description, including estimated settings, for all relays and Protection systems installed or to be installed on the <b>User's System</b> ;		<b>DPD</b>
(b) A full description of any auto-reclose facilities installed or to be installed on the <b>User's System</b> , including type and time delays;		<b>DPD</b>
(c) A full description, including estimated settings, for all relays and <b>Protection</b> systems installed or to be installed on the <b>Power Park Module or Generating Unit's</b> generator transformer, unit transformer, station transformer and their associated connections;		<b>DPD</b>
(d) For <b>Generating Units (other than Power Park Units)</b> having a circuit breaker at the generator terminal voltage clearance times for electrical faults within the <b>Generating Unit</b> zone must be declared.		<b>DPD</b>
(e) Fault Clearance Times: Most probable fault clearance time for electrical faults on any part of the <b>Users System</b> directly connected to the <b>NGC Transmission System</b> .	mSec	<b>DPD</b>

<u>DATA DESCRIPTION</u>	<u>UNITS</u>	<u>DATA CATEGORY</u>
<b><u>POWER PARK MODULE/UNIT PROTECTION SYSTEMS</u></b>		
<u>Details of settings for the following <b>Power Park Module/Unit</b> protection relays:</u>		
<u>(a) Under frequency,</u>		<b><u>DPD</u></b>
<u>(b) Over Frequency,</u>		<b><u>DPD</u></b>
<u>(c) Under Voltage, Over Voltage,</u>		<b><u>DPD</u></b>
<u>(d) Rate of Change of Frequency,</u>		<b><u>DPD</u></b>
<u>(e) Rotor Over current</u>		<b><u>DPD</u></b>
<u>(f) Stator Over current,</u>		<b><u>DPD</u></b>
<u>(g) High Wind Speed Shut Down Level</u>		<b><u>DPD</u></b>