

Issue	Revision
4	0

The Statement of the Connection Charging Methodology

Effective from 1 April 2004

About this Document

This document describes the methodology that National Grid Company plc (National Grid) employs to levy charges for connection to its transmission system. This document is one of a suite of three documents that describe National Grid's charges and the methodologies behind them. The other documents are:

- **The Statement of the Use of System Charging Methodology**
- **The Statement of Use of System Charges**

These are available on our **Charging website** at:

www.nationalgrid.com/uk/indinfo/charging

This Statement of the Connection Charging Methodology Issue 4 is effective from 1 April 2004.

This document has been published by National Grid in accordance with Condition C7B of National Grid's Transmission Licence and is approved by the Gas and Electricity Markets Authority (the Authority).

If you require further details about any of the information contained within this document or have comments on how this document might be improved please contact our **Charging Team**, preferably by email at:

charging.enquiries@ngtuk.com

or at:

NGT House
Warwick Technology Park
Gallows Hill
Warwick
CV34 6DA

Telephone 01926 654633

Contents

GENERAL INTRODUCTION	5
National Grid's Licence Obligations	5
Relevant Objectives	6
The Contractual Framework	7
CHAPTER 1: PRINCIPLES	8
Costs and their Allocation	8
Connection/Use of System Boundary	8
CHAPTER 2: THE CALCULATION OF THE BASIC ANNUAL CONNECTION CHARGE FOR AN ASSET	10
Pre and Post Vesting Connections	10
Calculation of the Gross Asset Value (GAV)	10
Calculation of Net Asset Value	11
Capital Components of the Connection charge for Post Vesting Connection Assets	11
Capital Components of the Connection charge for Pre Vesting Connection Assets	12
Non-Capital Components - Charging for Maintenance and Transmission Running Costs	12
Part A: Site Specific Maintenance Charges	13
Part B: Transmission Running Costs	13
The Basic Annual Connection Charge Formula	13
Adjustment for Capital Contributions	14
CHAPTER 3: OTHER CHARGES	15
One-off Works	15
Miscellaneous Charges	16
Rental sites	16
Final Metering Scheme (FMS)/Energy Metering Systems	16
CHAPTER 4: CONNECTION AGREEMENTS	17
Indicative Agreement	17
Outturning the Indicative Agreement	17
Firm Price Agreement	17
Monthly Connection Charges	17
CHAPTER 5: TERMINATION CHARGES	19
Charges Liable	19
Repayment on Re-Use of Assets	20
Valuation of Assets that are re-used as connection assets or existing infrastructure assets re-allocated to connection	20
CHAPTER 6: CONTESTABILITY	21
Contestability in Construction	21
Contestability in the Maintenance Service	21
Contestability Procedure and Connection Terms	22
CHAPTER 7: ASSET REPLACEMENT	23
Asset Replacement that includes a change of Voltage	23
CHAPTER 8: DATA REQUIREMENTS	25
CHAPTER 9: APPLICATIONS	26
APPENDIX 1: ILLUSTRATIVE CONNECTION CHARGES	27
2004/2005 First Year Connection Charges based on the RPI Method (6% rate of return)	27
Connection Examples	29
APPENDIX 2: EXAMPLES OF CONNECTION CHARGE CALCULATIONS	35
Example 1	35
Example 2	36
Example 3	36
Example 4	37
CHAPTER 10: NOMINALLY OVER EQUIPPED CONNECTION SITES	38
Historical	38

Early Construction	38
Connection site Specific Technical or Economic Conditions	38
GLOSSARY	39
INDEX TO THE STATEMENT OF THE CONNECTION CHARGING METHODOLOGY (ISSUE 4) REVISIONS	44

General Introduction

National Grid's Licence Obligations

- 1 As the holder of the Transmission Licence for England and Wales, National Grid is required by the Electricity Act 1989, as amended by the Utilities Act 2000, to develop and maintain an efficient, co-ordinated and economical system of electricity transmission and to facilitate competition in the generation and supply of electricity. In common with other licence holders, National Grid is also required by Schedule 9 of the Electricity Act to have regard for the effects of its activities on the environment.
- 2 National Grid's Transmission Licence Conditions were changed by the Secretary of State through the Utilities Act 2000 as part of the implementation of the New Electricity Trading Arrangements (NETA). Following the changes, Licence Condition C7B of the Transmission Licence states that:

'The Licensee (National Grid) shall by the date this Condition comes into effect prepare a statement approved by the Authority of the Connection Charging Methodology in relation to charges, including charges:

 - a. *for the carrying out of works and the provision and installation of electrical lines or electrical plant or meters for the purposes of connection (at entry and exit points) to the Licensee's Transmission System;*
 - b. *in respect of extension or reinforcement of the Licensee's Transmission System rendered (at the Licensee's discretion) necessary or appropriate by virtue of providing connection to or Use of System to any person seeking connection;*
 - c. *in circumstances where the electrical lines or electrical plant to be installed (at the Licensee's discretion) of greater size than that required for use of system by the person seeking connection;*
 - d. *for maintenance and repair (including any capitalised charge) required of electrical lines or electrical plant or meters provided or installed for making a connection to the Licensee's Transmission System; and*
 - e. *for disconnection from the Licensee's Transmission System and the removal of electrical plant, electrical lines and meters following disconnection,'*
- 3 National Grid is also required by the Transmission Licence:
 - *to offer terms for connection to and use of its system or for the modification of an existing connection within three months of application;*
 - *to offer terms for use of system only within 28 days of application;*
 - *not to discriminate between any persons or class or classes of persons in providing use of system or in carrying out works for connection.*
- 4 Licence Condition C7G also requires National Grid to publish information on circuit capacity, forecast power flows and loading on each part of the transmission system, fault levels for each transmission node and other relevant information. This is published annually by National Grid in the Seven Year Statement. The Seven Year Statement is intended to help existing and prospective Users of the transmission

system in identifying those parts of the transmission system most suited to new connections and to the transport of electricity.

Relevant Objectives

- 5 As part of Licence Condition C7B National Grid has to ensure that the Connection Charging Methodology meets the relevant licence objectives as specified in C7A(5) and C7B(11) in relation to connection charges. The relevant objectives are set out as follows:
 - a. *That compliance with the Connection Charging Methodology facilitates effective competition in the generation and supply of electricity and (so far as consistent therewith) facilitates competition in the sale, distribution and purchase of electricity;*
 - b. *That compliance with the Connection Charging Methodology results in charges which reflect, as far as reasonably practicable, the costs incurred by the Licensee in its Transmission Business;*
 - c. *That so far as is consistent with the sub-paragraphs (a) and (b), the Connection Charging Methodology, as far as is reasonably practicable, properly takes account of the developments in the Licensee's Transmission Business;*
 - d. *In so far as consistent with sub paragraphs (a), (b) and (c) of facilitating competition in the carrying out of works for connection to the Licensee's Transmission System.*
- 6 The Licence states that National Grid must keep the Connection Charging Methodology under review at all times for the purpose of ensuring that it meets the relevant objectives outlined above.
- 7 National Grid may make modifications to the Methodology as may be required for the purpose of better meeting the relevant objectives above.
- 8 Before making any modifications, unless it has been agreed otherwise with the Authority, National Grid will consult with CUSC parties for a period of at least 28 days within which written representations can be made.
- 9 A report will then be issued to the Authority by National Grid setting out the terms of the modification, representations made, any change to the terms of the modification, how the modification better meets the relevant objectives and a timetable and date for implementation of the modification.
- 10 Unless the Authority has, within 28 days of the report being furnished to it, given a direction that the modification may not be made, National Grid will make the modification to the Connection Charging Methodology.
- 11 Once a modification is made National Grid will issue a revised statement showing the changed Connection Charging Methodology. The revised Connection Charging Methodology statement will supersede all previous statements from the date of its issue.

The Contractual Framework

- 12 The Connection and Use of System Code (CUSC) is a multi-party document creating contractual obligations among and between all users of the transmission system, parties connected to the transmission system and National Grid. Persons wishing to use and/or connect to the transmission system will be required to accede to the CUSC by signing the Framework Agreement and to enter into a Bilateral Agreement with National Grid.
- 13 National Grid continues to request that Small Power Stations make a formal application for use of the system. National Grid can then assess the potential impact on the transmission system and consider what form of agreement, if any, may be required.
- 14 The CUSC and individual User's Bilateral Agreements set out the terms and conditions applicable for use of and/or connection to the transmission system. In particular, they set out the User's obligations to:
- pay all use of system and connection charges;
 - comply with the provisions of the Grid Code;
 - sign on to the Balancing and Settlement Code (BSC);
 - enter into an appropriate Mandatory Services Agreement.
- 15 Additionally, each Bilateral Agreement details the information on which the User's connection charges are based:
- Appendix A of each Bilateral Agreement lists the connection assets by description, age and allocation to the User;
 - Appendix B identifies the connection charges;
- 16 If a User fails to fulfil their obligations, their entitlement to use and/or be connected to the transmission system will cease. The User will be liable for all charges that may arise up to the end of the current Financial Year and, for connection, the appropriate termination sum.
- 17 When a User applies for a new connection to the system or to modify an existing connection they may be required to enter into a Construction Agreement. Within the Construction Agreement there will be provisions for site specific elements such as Consents and Final Sums.

Chapter 1: Principles

Costs and their Allocation

- 1.1 Connection charges enable National Grid to recover, with a reasonable rate of return, the costs involved in providing the assets which afford connection to the transmission system.
- 1.2 Connection charges relate to the costs of assets installed solely for and only capable of use by an individual User.
- 1.3 National Grid's connection charges are designed not to discriminate between Users or classes of User. The methodology is applied to both connections that were in existence at Vesting (30 March 1990) and those that have been provided since.

Connection/Use of System Boundary

- 1.4 The first step in setting charges is to define the boundary between connection assets and transmission system infrastructure assets.
- 1.5 Originally, at Vesting, a connection boundary definition including generation and demand spurs existed. In 1996, the Office of Electricity Regulation (OFFER) approved that this be amended to a "Generation Only Spurs" approach. Subsequently in 2003, following National Grid's extensive Charging Review, the Authority approved further change to implement a shallow single user boundary definition with no spurs retained within connection.
- 1.6 In general, connection assets are defined as those assets solely required to connect an individual User to the Transmission System, which are not and would not normally be used by any other connected party (i.e. "single user assets"). For the purposes of this Statement, all connection assets at a given location shall together form a connection site.
- 1.7 Connection assets are defined as all those single user assets which:
 - a) for Double Busbar type connections, are those single user assets connecting the User's assets and the first National Grid owned substation, up to and including the Double Busbar Bay;
 - b) for teed or mesh connections, are those single user assets from the User's assets up to, but not including, the HV disconnecter.
- 1.8 Shared assets at a banked connection arrangement will not normally be classed as connection assets except where both legs of the banking are single user assets under the same Bilateral Connection Agreement.
- 1.9 Where customer choice influences the application of standard rules to the connection boundary, affected assets will be classed as connection assets. For example, as National Grid does not normally own busbars below 275kV, where National Grid and the customer agree that National Grid will own the busbars at a low voltage substation, the assets at that substation will be classed as connection assets and will not automatically be transferred into infrastructure.

- 1.10 The design of some connection sites may not be compatible with the basic boundary definitions in 1.7 above. In these instances, a connection boundary consistent with the principles described above will be applied.

Chapter 2: The Calculation of the Basic Annual Connection Charge for an Asset

Pre and Post Vesting Connections

- 2.1 Post Vesting connection assets are those connection assets that have been commissioned since 30 March 1990. Pre Vesting connection assets are those which were commissioned on or before the 30 March 1990.
- 2.2 The basic connection charge has two components. A non-capital component, for which both pre and post vesting assets are treated in the same way and a capital component for which there are slightly different options available for pre and post vesting assets. These are detailed below.

Calculation of the Gross Asset Value (GAV)

- 2.3 The GAV represents the initial total cost of an asset to National Grid. For a new asset it will be the costs incurred by National Grid in the provision of that asset. Typically the GAV is made up of the following components:

Construction Costs - Costs of bought in services
National Grid Engineering - Allocated equipment and direct engineering cost
Interest During Construction – Financing cost
National Grid Liquidated Damages Premiums - Premium required to cover Liquidated damages if applicable.

Some of these elements may be optional at the User's request and are a matter of discussion and agreement at the time the connection agreement is entered into.

- 2.4 The GAV of an asset is re-valued each year normally using one of two methods. For ease of calculation, April is used as the base month.
- In the Modern Equivalent Asset (MEA) revaluation method, the GAV is indexed each year with reference to the prevailing price level for an asset which performs the same function as the original asset;
 - In the RPI revaluation method, the original cost of an asset is indexed each year by the Retail Price Index (RPI) formula set out in paragraph 2.6;
- 2.5 In the MEA revaluation method, the MEA value is based on a typical asset. An MEA ratio is calculated to account for specific site conditions, as follows:
- The outturn GAV (as calculated in paragraph 2.3 above) is re-indexed by RPI to the April of the Financial Year the Charging Date falls within;
 - This April figure is compared with the MEA value of the asset in the Financial Year the Charging Date falls within and a ratio calculated;
 - If the asset was commissioned at a Connection Site where, due to specific conditions, the asset cost more than the standard MEA value, the ratio would be greater than 1. For example, if an asset cost 10% more to construct and commission than the typical asset the MEA ratio would be 1.1. If, however, the asset was found only to cost 90% of the typical MEA value the ratio would be 0.9;

- The MEA ratio is then used in all future revaluations of the asset. The April GAV of the asset in any year is thus the current MEA value of the asset multiplied by the ratio calculated for the Financial Year the Charging Date falls within.

2.6 The RPI revaluation method is as follows:

- The outturn GAV (as calculated in paragraph 2.3 above) is re-indexed by RPI to the April of the Financial Year the Charging Date falls within. This April GAV is thus known as the Base Amount;
- The Base Amount GAV is then indexed to the following April by using the RPI formula used in National Grid's Price Control. April GAVs for subsequent years are found using the same process of indexing by RPI.

$$\text{i.e. } GAV_n = GAV_{n-1} * RPI_n$$

- The RPI calculation for year n is as follows:

$$RPI_n = \frac{\left[\text{May to October average RPI Index} \right]_{n-1}}{\left[\text{May to October average RPI Index} \right]_{n-2}}$$

Calculation of Net Asset Value

2.7 The Net Asset Value (NAV) of each asset for year n, used for charge calculation, is the average (mid year) depreciated GAV of the asset. The following formula calculates the NAV of an asset, where A_n is the age of the asset (number of completed charging years old) in year n:

$$NAV_n = GAV_n * \frac{\text{Depreciation Period} - (A_n + 0.5)}{\text{Depreciation Period}}$$

2.8 In constant price terms an asset with an initial GAV of £1m and a depreciation period of 40 years will normally have a NAV in the year of its commissioning of £0.9875m (i.e. a reduction of 1.25%) and in its second year of £0.9625m (i.e. a further reduction of 2.5% or one fortieth of the initial GAV). This process will continue with an annual reduction of 2.5% for each year of the asset's life.

Capital Components of the Connection charge for Post Vesting Connection Assets

2.9 The standard terms for a connection offer will be:

- 40 year life (with straight line depreciation);
- RPI indexation

2.10 In addition a number of options exist:

- a capital contribution based on the allocated GAV at the time of commissioning will reduce capital. Typically a capital contribution will include costs to cover the elements outlined below and charges are calculated as set out in the equations below;

- Construction costs
- National Grid Engineering costs (Engineering Charge x job hours)
- Interest During Construction (IDC)
- Return element (6%)
- National Grid Liquidated Damages Premium (LD) (if applicable)

General Formula:

Capital Contribution Charge = (Construction Costs + Engineering Charges) x (1+Return %) + IDC + LD Premium

- MEA revaluation which is combined with a 7.5% rate of return, as against 6% on the standard RPI basis;
 - annual charges based on depreciation periods other than 40 years;
 - annuity based charging;
 - indexation of GAVs based on principles other than MEA revaluation and RPI indexation. No alternative forms of indexation have been employed to date.
- 2.11 For new connection assets, should a User wish to agree to one or more of the options detailed above, instead of the standard connection terms, the return elements charged by National Grid may also vary to reflect the re-balancing of risk between National Grid and the User. For example, if Users choose a different indexation method, an appropriate rate of return for such indexation method will be derived.

Capital Components of the Connection charge for Pre Vesting Connection Assets

- 2.12 The basis of connection charges for assets commissioned on or before 30 March 1990 is broadly the same as the standard terms for connections made since 30 March 1990. Specifically charges for pre vesting connection assets are based on the following principles:
- The GAV is the 1996/97 charging GAV (MEA re-valued from vesting) subsequently indexed by the same measure of RPI as used in National Grid's Price Control;
 - 40 year life (with straight line depreciation);
 - 6% rate of return
- 2.13 Pre-vesting 1996 MEA GAVs for Users' connection sites are available from National Grid on request from the **Charging Team**.

Non-Capital Components - Charging for Maintenance and Transmission Running Costs

- 2.14 The non-capital component of the connection charge is divided into two parts, as set out below. Both of these non-capital elements will normally be identified in the charging appendices of relevant Bilateral Agreements.

Part A: Site Specific Maintenance Charges

- 2.15 This is a maintenance only component which is calculated on a site specific basis for National Grid's connection assets and also recovers a proportion of the overheads associated with National Grid's maintenance activity for National Grid's connection assets.
- 2.16 Users' site specific maintenance charges for National Grid assets will comprise two elements:
- a direct maintenance cost associated with actual site costs and;
 - an apportionment of non-asset specific overhead costs associated with the maintenance activity.
- Both elements will be based on actual costs incurred in the relevant charging year as reported in National Grid's maintenance cost capture system.
- 2.17 Thus for a relevant charging year, the User will be charged for maintenance costs incurred for connection assets on that site for that charging year.
- 2.18 As the site specific maintenance charge is based on actual costs, initially a charge based on an average apportionment of GAV will be levied across all sites. Initially, this will be 0.5% of GAV but will be subject to review as appropriate. Subsequently, in July after the end of the relevant year, there will be a site specific adjustment made to reflect the actual costs incurred and this will be incorporated into October invoices.

Part B: Transmission Running Costs

- 2.19 The Transmission Running Cost factor is calculated each year to reflect the appropriate amount of other Transmission Running Costs (rates, operation, indirect overheads) incurred by National Grid's Transmission Owner Activity (TO) function that should be attributed to connection assets. This is calculated by taking total Transmission Running Costs for the TO function and dividing by the total transmission business GAV. This cost factor is therefore expressed as a percentage of an asset's GAV. In 2004/05, the Transmission Running Cost factor is 1.48% of GAV.

The Basic Annual Connection Charge Formula

- 2.20 The charge for each connection asset in year n can be derived from the general formula below. This is illustrated more fully by the examples in **Appendix 2: Examples of Connection Charge Calculations.**

$$\text{Annual Connection Charge}_n = D_n (\text{GAV}_n) + R_n (\text{NAV}_n) + \text{SSF}_n (\text{RPIGAV}_n) + \text{TC}_n (\text{GAV}_n)$$

Where:

For n	=	year to which charge relates within the Depreciation Period
n	=	year to which charge relates
GAV _n	=	GAV for year n re-valued by relevant indexation method
RPIGAV _n	=	GAV for year n re-valued by RPI indexation
NAV _n	=	NAV for year n based on re-valued GAV _n
D _n	=	Depreciation rate as percentage (equal to 1/Depreciation Period) (typically 1/40 = 2.5% of GAV)

R_n	=	real rate of return for chosen indexation method (6% for RPI indexation, 7.5% for MEA Indexation)
SSF_n	=	Indicative Site Specific Factor for year n as a % (equal to the Site Specific Cost/Total Site GAV), reconciled in year n+1
TC_n	=	Transmission Running cost component for year n (other Transmission Owner Activity costs).
For n	=	year to which charge relates beyond the Depreciation Period
n	=	year to which charge relates
GAV_n	=	GAV for year n re-valued by relevant indexation method
$RPIGAV_n$	=	GAV for year n re-valued by RPI indexation
NAV_n	=	0
D_n	=	0
R_n	=	real rate of return for chosen indexation method (6% for RPI indexation, 7.5% for MEA Indexation)
SSF_n	=	Indicative Site Specific Factor for year n as a % (equal to the Site Specific Cost/Total Site GAV), reconciled in year n+1
TC_n	=	Transmission Running cost component for year n (other Transmission Owner Activity costs).

- 2.21 Note that, for the purposes of deriving asset specific charges for site specific maintenance, the RPI re-valued GAV is used. This is to ensure that the exact site charges are recovered from the assets at the site. The site costs are apportioned to the assets on the basis of the ratio of the asset GAV to total Site GAV. As different Users can choose different re-valuation methods for the same asset at a shared site, the RPI GAVs are used for simplicity to ensure the correct costs are recovered.

Adjustment for Capital Contributions

- 2.22 If a User chooses to make a 100% capital contribution towards their allocation of a connection asset then no capital charges will be payable and hence the connection charges for that asset would be calculated as follows:

$$\text{Annual Connection Charge}_n = SSF_n (RPIGAV_n) + TC_n (GAV_n)$$

- 2.23 If a User chooses to make a partial capital contribution towards their allocation of a connection asset, for example PCCF = 50%, then the connection charges for that asset would be calculated as follows:

$$\text{Annual Connection Charge}_n = D_n (GAV_n * PCCF) + R_n (NAV_n * PCCF) + SSF_n (RPIGAV_n) + TC_n (GAV_n)$$

PCCF = Partial Capital Contribution Factor

Modification of Connection Assets

- 2.24 Where a modification to an existing connection occurs at the User's request or due to developments to the transmission system, their annual connection charges will reflect any additional connection assets which are necessary to meet the User's requirements. Charges will continue to be levied for existing assets which remain in service. Termination charges as described in **Chapter 5** below will be charged for any existing connection assets made redundant as a result of the modification.

Chapter 3: Other Charges

- 3.1 In addition to the basic annual connection charges set out above, the User may pay National Grid for certain other costs related to their connection. These will be set out in the Bilateral and Construction Agreements where appropriate and are described below.

One-off Works

- 3.2 To provide or modify a connection, National Grid may need to carry out works on the transmission system, which although directly attributable to the connection, may not give rise to additional connection assets. These works are defined as “one-offs”. Liability for one-off charges is established with reference to the principles laid out below:

- Where a cost cannot be capitalised into either a connection or infrastructure asset, typically a revenue cost
- Where a non-standard incremental cost is incurred as a result of a User's request, irrespective of whether the cost can be capitalised
- Termination Charges associated with the write-off of connection assets at the connection site.

- 3.3 The one-off charge is a charge equal to the cost of the works involved, together with a reasonable return, as shown in 3.4 below.

- 3.4 For information, the general formula for the calculation of the one-off charge for works is outlined below.

One-off Charge = (Construction Costs + Engineering Charges) x (1 + Return %) + IDC + LD Premium

Where: Engineering Charges = “Engineering Charge” x job hours
 Return % = 6%
 IDC = Interest During Construction
 LD Premium = National Grid Liquidated Damages Premium (if applicable)

- 3.5 The calculation of the one-off charge for write-off of assets is outlined below:

Write-off Charge = 100% of remaining NAV of redundant assets

- 3.6 One-offs are normally paid on an agreed date, which is usually upon completion of the works. However, arrangements may be agreed between National Grid and the User to pay the charge over a longer period. If a one-off is paid over a longer period it is termed a Transmission Charge. It is usually a depreciating finance charge or annuity based charge with a rate of return element and may include agreement on a schedule of termination payments if the agreement is terminated before the end of the annuity period. The charge is usually inflated annually by the same RPI figure that is used to inflate GAVs, though Users can request alternative indexation methods.

Miscellaneous Charges

- 3.7 Other contract specific charges may be payable by the User, these will be set out in the Bilateral and Construction Agreements where appropriate.

Rental sites

- 3.8 Where National Grid owns a site that is embedded within a distribution network, the connection charge to the User is based on the capital costs and overheads but does not include maintenance charges.

Final Metering Scheme (FMS)/Energy Metering Systems

- 3.9 Charges for FMS metering are paid by the registrant of the FMS metering at the connection site. It is charged on a similar basis as other National Grid Connection Assets. The electronic components of the FMS metering have a 15 year replacement and depreciation period whilst the non-electronic components normally retain a 40 year replacement and depreciation period (or a user specified depreciation period as appropriate).

Chapter 4: Connection Agreements

Indicative Agreement

- 4.1 The standard connection agreement offered by National Grid is an indicative price agreement. From the Charging Date as set out in the User's Bilateral Connection Agreement, the User's initial connection charge is based on a fair and reasonable estimate of the expected costs of the connection.

Outturning the Indicative Agreement

- 4.2 Once the works required to provide a new or modified connection are completed and the costs finalised, the connection scheme is "outturned". National Grid reconciles the monies paid by the User on the indicative charge basis against the charges that would have been payable based on the actual costs incurred in delivering the project together with any relevant interest. This process involves agreeing a new charging GAV (The Base Amount) with the User in line with the elements stated in paragraph 2.3 and then calculating connection charges with this GAV.
- 4.3 In addition, for Users that have chosen MEA revaluation their MEA ratios are agreed at outturn and this ratio is used for MEA revaluation in subsequent years.
- 4.4 In the case of connection asset replacement where there is no initiating User the outturn is agreed with the User at the site.

Firm Price Agreement

- 4.5 In addition to the options stated in paragraph 2.10 above, firm price agreements are also available. Typically with this option the charges to be incurred, and any indexation, are agreed between National Grid and the User and connection charges are not recalculated once outturn costs are known. A typical example of a firm price agreement is:
- Capital Contribution
 - Firm Price GAV
 - Running Costs (based on a firm price GAV)
 - Fixed Schedule of Termination Amounts
- 4.6 When a User selects a firm price agreement some or all of the above elements can be made firm. Any elements of the agreement that have not been made firm will be charged on an indicative basis in accordance with this statement.
- 4.7 Final Sums and Consents costs are never made firm in a Firm Price Agreement. Details of both are set out in the Construction Agreement.

Monthly Connection Charges

- 4.8 The connection charge is an annual charge payable monthly.
- 4.9 If the initial Charging Date does not fall within the current Financial Year being charged for and there are no revisions to charges during the year, the monthly connection charge will equal the annual connection charge divided by twelve.

- 4.10 For the Financial Year in which the Charging Date occurs (as set out in the User's Bilateral Agreement) or for any Financial Year in which a revision to charges has occurred during the Financial Year, for each complete calendar month from the Charging Date (or effective date of any charge revision) to the end of the Financial Year in which the Charging Date (or charge revision) occurs, the monthly connection charge shall be equal to the annual connection charge divided by twelve.
- 4.11 For each part of a calendar month, the charge will be calculated as one twelfth of the annual connection charge prorated by the ratio of the number of days from and including the Charging Date to the end of the month that the Charging Date falls in and the number of days in that month.
- 4.12 For example, say the annual connection charge for Financial Year 1999/2000 is £1.2m and the Charging Date falls on the 15th November 1999, the monthly charges for the Financial Year 1999/2000 would be as follows:
- November = $£1,200,000/12 * (16/30)$ = £53,333.33
 - Dec 99, Jan 00, Feb 00, Mar 00 = $£1,200,000/12$ = £100,000.00
- 4.13 The above treatment does not apply to elements such as Miscellaneous Charges (as defined in 3.7) and Transmission Charges (annuitised one-offs, as defined in 3.6). If the Charging Date falls within a Financial Year, then the full annual charge will remain payable and will be spread evenly over the remaining months. This is because these payments are an annuitisation of charges which would normally be paid up-front as one-off payments.

Chapter 5: Termination Charges

Charges Liable

5.1 Where a User wholly or partially disconnects from the transmission system they will pay a termination charge. The termination charge will be calculated as follows:

- Where the connection assets are made redundant as a result of the termination or modification of a Bilateral Connection Agreement, the User will be liable to pay an amount equal to the NAV of such assets as at the end of the financial year in which termination or modification occurs, plus:
- The reasonable costs of removing such assets. These costs being inclusive of the costs of making good the condition of the connection site
- If a connection asset is terminated before the end of a Financial Year, the connection charge for the full year remains payable. Any remaining Use of System Charges (TNUoS and BSUoS) also remain payable
- For assets which National Grid has determined to replace upon the expiry of the relevant Replacement Period in accordance with the provisions set out in the CUSC and in respect of which a notice to Disconnect or terminate has been served in respect of the Connection Site at which the assets were located; and due to the timing of the replacement of such assets, no Connection Charges will have become payable in respect of such assets by the User by the date of termination; the termination charges will include the reasonable costs incurred by National Grid in connection with the installation of such assets
- Previous capital contributions will be taken into account

5.2 The Calculation of Termination amounts for financial year n is as follows:

$$\text{Termination Charge}_n = \text{UoS}_n + \text{C}_n + \text{NAV}_{an} + \text{R} - \text{CC}$$

Where:

UoS_n = Outstanding Use of System Charge for year (TNUoS and BSUoS)

C_n = Outstanding Connection Charge for year

NAV_{an} = NAV of Type A assets as at 31 March of financial year n

R = Reasonable costs of removal of redundant assets and making good

CC = An allowance for previously paid capital contributions

5.3 Examples of reasonable costs of removal for terminated assets and making good the condition of the site include the following:

- If National Grid terminates a circuit breaker as a result of a User leaving a site, this may require modifications to the protection systems.
- If an asset were terminated and its associated civils had been removed to 1m below ground then the levels would have to be made up. This is a common condition of planning consent.

Repayment on Re-Use of Assets

- 5.4 If any assets in respect of which a termination charge was made are re-used at the same site or elsewhere on the system, including use by National Grid as infrastructure assets, National Grid will make a payment to the original terminating User to reflect the fact that the assets are being re-used.
- 5.5 The arrangements for such repayments for re-use of Assets are that National Grid will pay the User a sum equal to the lower of:
- i.) the Termination Amount paid in respect of such National Grid Assets; or
 - ii.) the NAV attributed to such National Grid Assets for charging purposes upon their re-use
- less any reasonable costs incurred by National Grid in respect of the storage of those assets.
- 5.6 The definition of re-use is set out in the CUSC. Where National Grid decides to dispose of a terminated asset where it is capable of re-use National Grid shall pay the User an appropriate proportion of the sale proceeds received.

Valuation of Assets that are re-used as connection assets or existing infrastructure assets re-allocated to connection

- 5.7 If an asset is reused following termination or allocated to connection when it has previously been allocated to TNUoS, a value needs to be determined for the purposes of connection charges. In both instances the connection charge will be based on the standard formula set out in paragraph 2.20. The Gross Asset Value will be based on the original construction costs and indexed by RPI. Where original costs are not known a reasonable value will be agreed between National Grid and the User based on similar types of asset in use. The Net Asset Value will be calculated as if the asset had been in continuous service as a connection asset from its original commissioning date taking into account the depreciation period.
- 5.8 Where an asset has been refurbished or updated to bring it back into service a new value and an appropriate replacement period will be agreed between National Grid and the User. This will be based on the value of similar types of asset in service and the costs of the refurbishment.

Chapter 6: Contestability

- 6.1 Some connection activities may be undertaken by the User. The activities are the provision, or construction, of connection assets, the financing of connection assets and the ongoing maintenance of those assets. While some Users have been keen to see contestability wherever possible, contestability should not prejudice system integrity, security and safety. These concerns have shaped the terms which are offered for contestability in construction and maintenance.

Contestability in Construction

- 6.2 Users wishing to provide (construct) connection assets have been able to do so since 1990. Formal arrangements for Users exercising this choice are available. Further information on User choice in construction can be obtained from the **Charging Team**.

Contestability in the Maintenance Service

- 6.3 National Grid has identified assets which could be maintained by Users without jeopardising system integrity and thus the interests of all National Grid Users. The two diagrams in **Example 6 of Appendix 1: Illustrative Connection Charges** identify those assets which fall into this category. In broad terms, these are supergrid transformers and associated equipment. However, as certain activities related to the maintenance of these assets can also impinge on system security, those activities which are core to system security will remain with National Grid. The division between those activities which are contestable and non-contestable is set out below:

Non-Contestable

- Safety management
- Emergency response to operational requirements
- Wayleave management
- Maintenance policy and specification
- Site access
- Outage management
- Protection Maintenance

Contestable

- Routine planned and unplanned maintenance of equipment and civil works
 - Provision of Maintenance spares
 - Emergency works
- 6.4 Users opting to carry out these contestable activities for themselves will have to provide the activities as a complete package. It will not be possible for Users to select certain aspects of the contestable package in isolation.
- 6.5 The site specific maintenance service charge will be adjusted to reflect situations where Users opt to provide these maintenance activities themselves. The site specific charge for that site will reflect solely the expected costs of National Grid's maintenance activity at that site.

- 6.6 The exact reduction in charges will depend on the period of time over which the User is carrying out the Contestable Maintenance Activity.

Contestability Procedure and Connection Terms

- 6.7 Users wishing to exercise choice in maintenance provision will enter into contracts to cover the provision of the contestable maintenance activities. A contractual relationship is essential as the contestable assets will remain under National Grid ownership. The contracts will ensure that the maintenance activities on these assets are consistent with those carried out on all connection assets. Each year the following notification procedure shall apply in respect of contestable maintenance to allow time for consideration and identification of contractual terms and the identification of charge adjustments:

15 September	Deadline for formal notification to National Grid of a User's intention to provide contestable maintenance from 1 April of the next financial year
Mid-September onwards	Period for contract negotiation
30 November	Deadline for execution of contract
Week commencing 2 January	Provisional issue of connection charges as from 1 April, adjusted to reflect that the User is providing contestable maintenance

- 6.8 Where one of the dates above is not a business day, the nearest business day before that date will apply. The terms of the contract for maintenance contestability may be referred to the Authority in the case of a dispute.

Chapter 7: Asset Replacement

- 7.1 Appendix A of a User's Bilateral Connection Agreement specifies the age (number of complete charging years old), for charging purposes, of each of the National Grid assets at the Connection Site for the corresponding Financial Year. Connection charges are calculated on the assumption that the assets will not need to be replaced until the charging age has reached the duration of the asset's Replacement Period.

If a connection asset is to be replaced National Grid will enter into an agreement for the replacement with the User. Where replacement occurs before the original asset's charging age has reached the duration of its Replacement Period, National Grid will continue to charge for the original asset and make no charge to the existing User for the new asset until the original asset's charging age has reached the duration of its Replacement Period.

Where the replacement occurs after the original asset's charging age has reached the duration of its Replacement Period, National Grid will charge on the basis of the original asset until replaced and on the basis of the new asset on completion of the works.

- 7.2 When the original asset's charging age has reached the duration of its Replacement Period the User's charge will be calculated on the then Net Asset Value of the new asset. The new asset begins depreciating for charging purposes upon completion of the asset replacement.

The Basic Annual Connection Charge Formulae are set out in **Chapter 2: The Basic Annual Connection Charge Formula**.

Asset Replacement that includes a change of Voltage

- 7.3 There are a number of situations where an asset replacement scheme may involve a change in the voltage level of a User's connection assets. These replacement schemes can take place over a number of years and may involve a long transitory period in which connection assets are operational at both voltage levels.

- 7.4 These situations are inevitably different from case to case and hence further charging principles will need to be developed over time as more experience is gained. Set out below are some initial generic principles which have been applied to date. This methodology will be updated as experience develops.

- 7.5 The general principles used to date are to ensure that, in the transitory period of an asset replacement scheme, the User does not pay for two full transmission voltage substations and that the charges levied reflect the Replacement Period of the original connection assets. In addition, in line with paragraph 7.1 above, charges will only be levied for the new assets once the original assets would have required replacement.

- 7.6 For example, National Grid, in investing to meet a future Security Standard need on the main transmission system, may require the asset replacement of an existing 275kV substation with a 400kV substation prior to the expiry of the original assets' Replacement Period. In this case, National Grid will seek to recover the connection asset component via connection charges when the assets replaced were due for asset replacement. Prior to this, the User should not see an increase in charges and therefore the investment costs would be recovered through TNUoS charges.

In addition, if in the interim stage the User has, say, one transformer connected to the 275kV substation and one transformer connected to the 400kV substation, the charge will comprise an appropriate proportion of the HV assets at each site and not the full costs of the two substations. Note that the above described treatment is only made for transitory asset replacement and not enduring configurations where a User has connection assets connected to two different voltage substations.

Chapter 8: Data Requirements

- 8.1 Under the current connection charging methodology no data is required from Users in order to calculate the connection charges payable by the User.

Chapter 9: Applications

- 9.1 Application fees are payable in respect of applications for new connection agreements and modifications to existing agreements based on the reasonable costs National Grid incurs in processing these applications. Users can opt to pay a fixed price application fee (derived from analysis of the historical costs of similar applications) in respect of their application or pay the actual costs incurred. The fixed price fees for applications are detailed in the **Statement of Use of System Charges**.
- 9.2 If a User chooses not to pay the fixed fee, the application fee will be based on an advance of National Grid Engineering and out-of pocket expenses and will vary according to the size of the scheme and the amount of work involved. Where actual expenses exceed the advance, National Grid will issue an invoice for the excess. Conversely, where National Grid does not use the whole of the advance, the balance will be refunded.
- 9.3 National Grid will refund application fees and consent payments made under the Construction Agreement either on commissioning or against the charges payable in the first three years of the new or modified agreement. The following conditions apply:
- The refund will be net of external costs;
 - Where a new or modified agreement is signed and subsequently modified at the User's request before any charges become payable, National Grid will refund the original application fee. National Grid will not refund the fees in respect of the subsequent modification(s).

Appendix 1: Illustrative Connection Charges

2004/2005 First Year Connection Charges based on the RPI Method (6% rate of return)

The following table provides an indication of typical charges for new connection assets. Before using the table, it is important to read through the notes below as they explain the assumptions used in calculating the figures.

Calculation of Gross Asset Value (GAV)

The GAV figures in the following table were calculated using the following assumptions:

- Each asset is new
- The GAV includes estimated costs of construction, engineering, Interest During Construction and Liquidated Damages premiums

For details of the Calculation of the Gross Asset Value, see Chapter 2 of this Statement.

Calculation of first year connection charge

The first year connection charges in the following table were calculated using the following assumptions:

- The assets are new
- The assets are depreciated over 40 years
- The rate of return is assumed to be 6% for RPI indexation
- The connection charges include maintenance costs
- The connection charges include Transmission Running Costs at a rate of 1.48% of the GAV

For details of the Basic Annual Connection Charge Formula, see Chapter 2 of this Statement.

Please note that the actual charges will depend on the specific assets at a site. Agreement specific NAVs and GAVs for each User will be made available on request.

Notes on Assets

The charges for Double and Single Busbar Bays include electrical and civil costs.

Transformer cable ratings are based on winter soil conditions.

In this example, transformer charges include civil costs of plinth and noise enclosure and estimated transport costs, but not costs of oil dump tank and fire trap moat. Transport costs do not include hiring heavy load sea transportation or roll-on roll-off ships.

	£000's					
	400kV		275kV		132kV	
	GAV	Charge	GAV	Charge	GAV	Charge
Double Busbar Bay	1929	201	1581	165	528	55
Single Busbar Bay	1534	160			387	40
Transformer Cables 100m (incl. Cable sealing ends)						
120MVA			734	76	235	24
180MVA	1122	117	734	76	242	25
240MVA	1148	119	742	77	250	26
750MVA	1164	121	856	89		
Transformers						
45MVA 132/66kV					887	92
90MVA 132/33kV					853	89
120MVA 275/33kV			1715	178		
180MVA 275/66kV			1855	193		
180MVA 275/132kV			1836	191		
240MVA 275/132kV			1597	166		
240MVA 400/132kV	1761	183				

Connection Examples
Example 1

**NEW 400/132kV SUPERGRID CONNECTION
SINGLE SWITCH MESH TYPE**

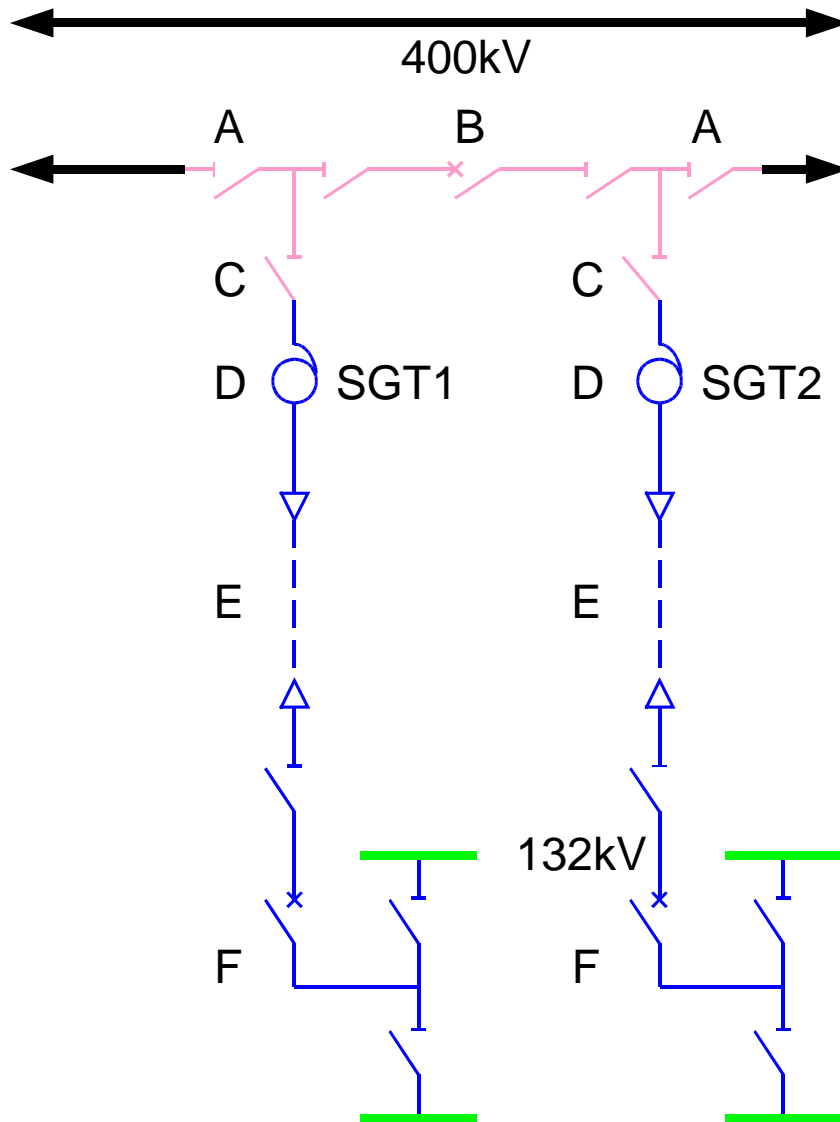

KEY:

- Existing NGC Assets (infrastructure)
- New NGC Assets (infrastructure)
- New NGC Assets wholly charged to customer
- Customer Assets

SCHEDULE FOR NEW CONNECTION				
Ref	kV	No	Description	First Year Charges (£000s)
D	400/132	2	240MVA Transformers	366
E	132	2	100m(eg) 240 MVA Cables	52
F	132	2	Double Busbar Transformer Bays	110
Total				528

Example 2

EXTENSION OF SINGLE SWITCH MESH TO FOUR SWITCH MESH (extension to single user site)

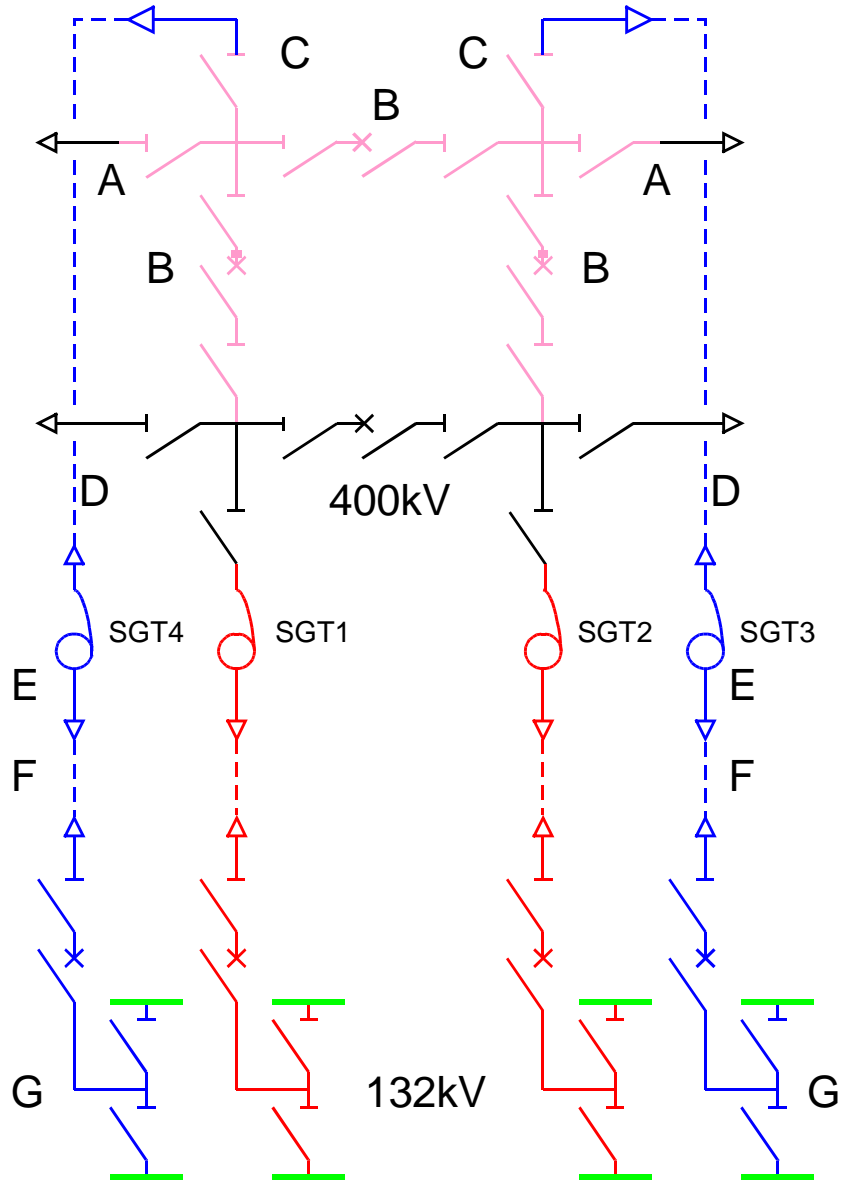

KEY:

- Existing NGC Assets (infrastructure)
- New NGC Assets (infrastructure)
- New NGC Assets wholly charged to customer
- Existing NGC Assets wholly charged to customer
- Customer Assets

SCHEDULE FOR EXTENSION				
Ref	kV	No	Description	First Year Charges (£000s)
D	400	2	100M(eg) 240 MVA Cables	238
E	400/132	2	240MVA Transformers	366
F	132	2	100m (eg) 240 MVA Cables	52
G	132	2	Double Busbar Transformer Bays (inc. Breaker)	110
Total				766

Example 3

**NEW 400/132KV SUPERGRID CONNECTION
DOUBLE BUSBAR TYPE**

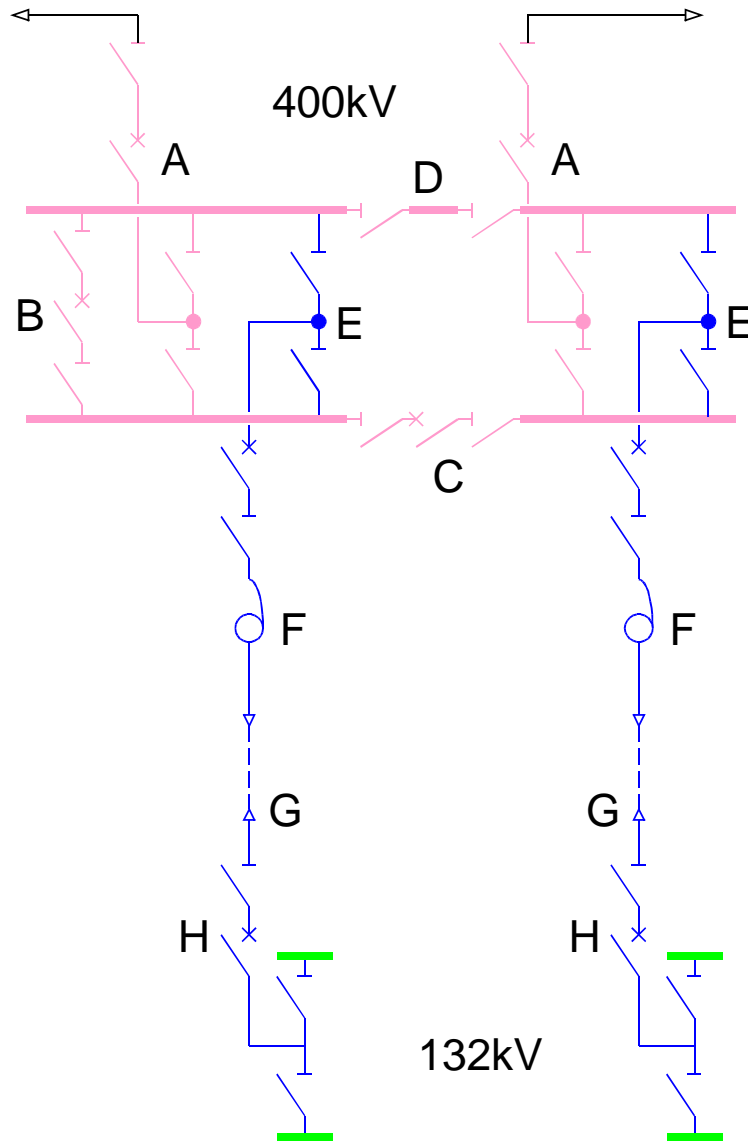

KEY:

- Existing NGC Assets (infrastructure)
- New NGC Assets (infrastructure)
- New NGC Assets wholly charged to customer
- Customer Assets

SCHEDULE FOR NEW CONNECTION				
Ref	kV	No	Description	First Year Charges (£000s)
E	400	2	Double Busbar Transformer Bays inc. breaker	402
F	400/132	2	240 MVA Transformers	366
G	132	2	100m(eg) 240MVA Cables	52
H	132	2	Double Busbar Transformer Bays inc. breaker	110
Total				930

Example 4

EXTENSION OF DOUBLE BUSBAR TO ACCOMMODATE THIRD TRANSFORMER (extension of single user site)

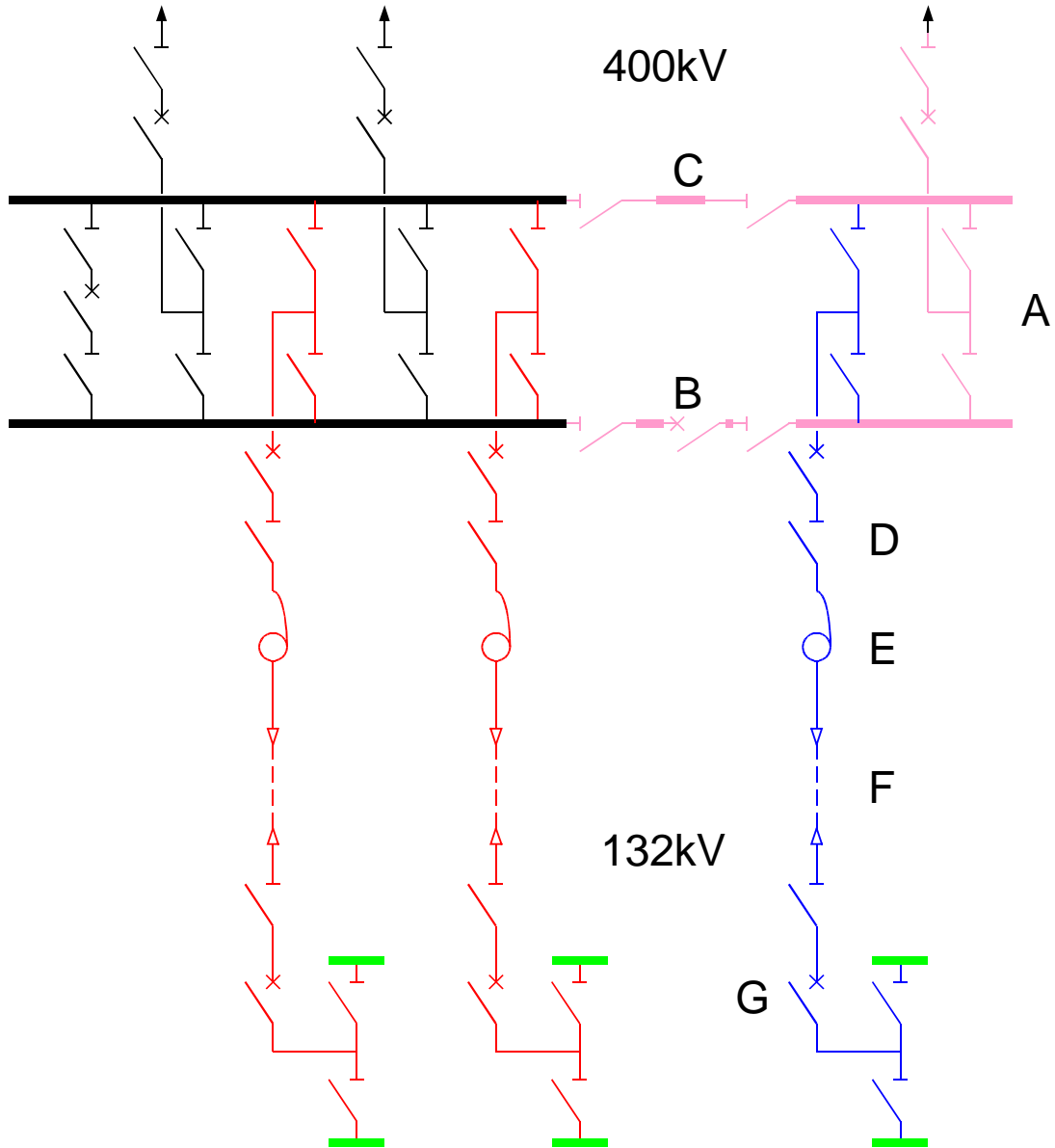

KEY:

- Existing NGC Assets (infrastructure)
- Existing NGC Assets wholly charged to customer
- New NGC Assets (infrastructure)
- New NGC Assets wholly charged to customer
- Customer Assets

SCHEDULE FOR EXTENSION				
Ref	kV	No	Description	First Year Charges (£000s)
D	400	1	Double Busbar Transformer Bay inc. breaker	201
E	400/132	1	240 MVA Transformer	183
F	132	1	100m (eg) 240MVA Cable	26
G	132	1	Double Busbar Transformer Bay inc. breaker	55
Total				465

Example 5

NEW GENERATION CONNECTING TO AN EXISTING SUBSTATION

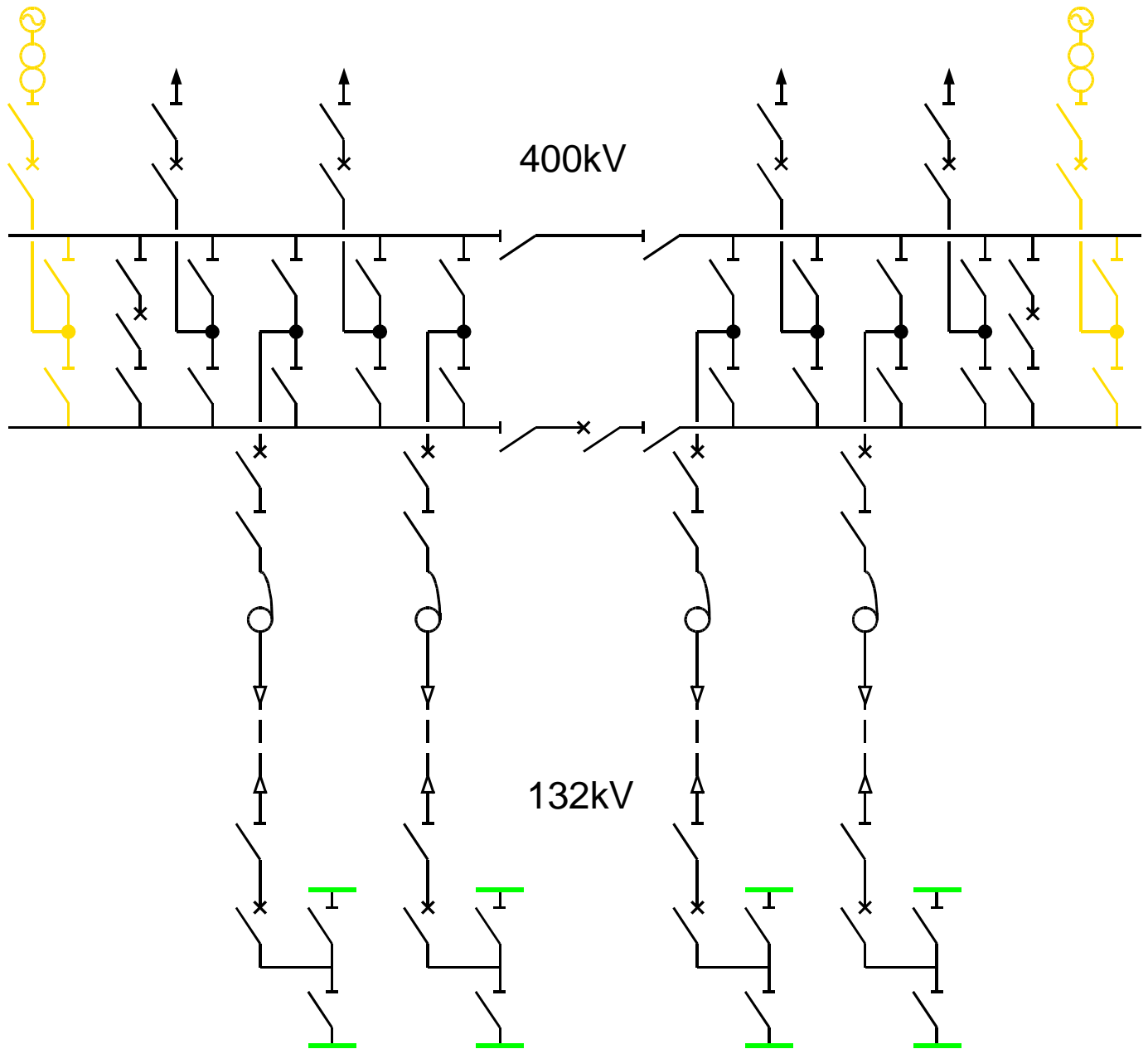

KEY:

- Existing NGC Assets (infrastructure)
- Distribution Customer Assets
- Generation Customer Assets

Example 6

CONTESTABLE MAINTENANCE

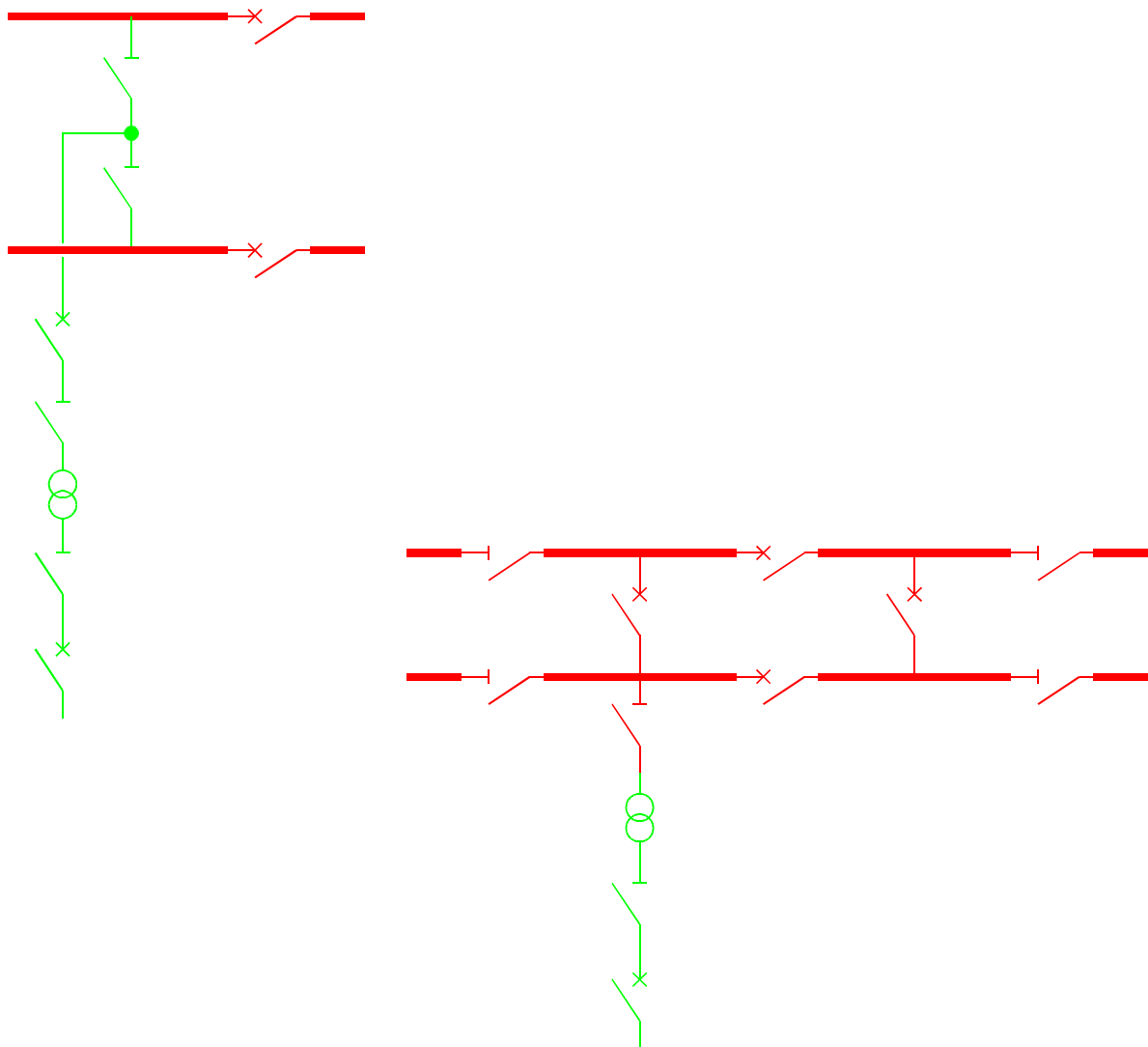

NON-CONTESTABLE WORK

1. Emergency Response to Operational Requirements
2. Wayleave Local Liaison
3. Maintenance Specification
4. NGC Quality Management Systems
5. Safety Management
6. Site Access

KEY:

- █ Contestable maintenance package not available for these assets
- █ Contestable maintenance package available for these assets only

Appendix 2: Examples of Connection Charge Calculations

The following examples of connection charge calculations are intended as general illustrations. The site specific maintenance charge will be based on the actual annual costs incurred by National Grid on a site basis over the maintenance cycle.

Example 1

This example illustrates the method of calculating the first year connection charge for a given asset value. This method of calculation is applicable to indicative price agreements for new connections, utilising the RPI method of charging, and assuming:

- i) the asset is commissioned on 1 April 2004
- ii) there is no inflation from year to year i.e. GAV remains constant
- iii) the Transmission Running Cost component remains constant throughout the 40 years
- iv) the asset is depreciated over 40 years
- v) the rate of return charge remains constant at 6% for the 40 year life of the asset
- vi) the asset is terminated at the end of its 40 year life

For the purpose of this example, the asset on which charges are based has a Gross Asset Value of £3,000,000 on 1 April 2004.

Charge	Calculation	
Site Specific Maintenance Charge (for example 0.5% of GAV)	$3,000,000 \times 0.5\%$	£15,000
Transmission Running Cost (1.48% of GAV)	$3,000,000 \times 1.48\%$	£44,400
Capital charge (40 year depreciation 2.5% of GAV)	$3,000,000 \times 2.5\%$	£75,000
Return on mid-year NAV (6%)	$2,962,500 \times 6\%$	£177,750
TOTAL		£312,150

The first year charge of £312,150 would reduce in subsequent years as the NAV of the asset is reduced on a straight-line basis.

This gives the following annual charges over time (assuming no inflation):

Year	Charge
1	£312,150
2	£307,650
10	£271,650
40	£136,650

Based on this example, charges of this form would be payable until 31 March 2044.

Example 2

The previous example assumes that the asset is commissioned on 1 April 2004. If it is assumed that the asset is commissioned on 1 July 2004, the first year charge would equal 9/12th of the first year annual connection charge i.e. £234,112.50. Furthermore, a final charge would be payable on the 40th anniversary of the asset i.e. 30th June 2044.

For the purposes of this example, the asset on which charges are based has a Gross Asset Value of £3,000,000 on 1 July 2004. Given the assumptions outlined in example 1, the charge for the final year (that being the 41st year) shall be calculated as 3/12th of the charge calculated below.

Charge	Calculation	
Site Specific Maintenance Charge (for example 0.5% of GAV)	3,000,000 x 0.5%	£15,000
Transmission Running Cost (1.48% of GAV)	3,000,000 x 1.48%	£44,400
Capital charge (40 year depreciation 2.5% of GAV)	3,000,000 x 2.5%	£75,000
Return on mid-year NAV (6%)	0 x 6%	£0
TOTAL		£134,400

This gives the following annual charges over time:

Year	Charge
1	£234,112.50 (connection charge for period July to March)
2	£307,650.00
10	£271,650.00
40	£136,650.00
41	£33,600.00 (connection charge for period April to June)

A new User connecting to the system in July 2004 will pay 9/12th of the annual connection charge in the first year and 3/12th of the annual connection charge in year 41.

Example 3

In the case of a firm price agreement, there will be two elements in the connection charge, a finance component and a running cost component. These encompass the four elements set out in the examples above. Using exactly the same assumptions as those in example 1 above, the total annual connection charges will be the same as those presented. No increase or decrease in these firm connection charges will result from a change in the sharing of the assets, or from a different methodology of charging subsequently being adopted by National Grid.

Example 4

If a User has chosen a 20-year depreciation period for their Post Vesting connection assets and subsequently remains connected at the site beyond the twentieth year their charges are calculated as follows.

For years 21-40 they will pay a connection charge based on the following formula:

$$\text{Annual Connection Charge}_n = \text{SSF}_n (\text{RPIGAV}_n) + \text{TC}_n (\text{GAV}_n)$$

The NAV will be zero and the asset will be fully depreciated so there will be no rate of return or depreciation element to the charge.

Chapter 10: Nominally Over Equipped Connection Sites

- 10.1 This chapter outlines examples of ways in which a connection site can be considered as having connection assets which exceed the strict, theoretical needs of the individual Users at the connection site. These can be described as:

Historical

- 10.2 This is where the connection assets at the connection site were installed to meet a requirement of the Users for connection capacity which no longer exists. An example would be where a User, at one time, had a requirement for, say, 270 MW. This would allocate three 240 MVA 400/132kV transformers to the User. Due to reconfiguration of that User's network only 200 MW is now required from the connection site. The lower requirement would only allocate two transformers, but all the transformers are kept in service. The connection assets will continue to be assigned to the User's connection, and charged for as connection, until the User makes a Modification Application to reduce the historical requirement. In some cases the Modified requirement will mean that Termination Payments will have to be made on some connection assets.

Early Construction

- 10.3 If a User has a multi-phase project, it may be necessary to install connection assets for the latter phases at the time of the first phase. These connection assets could be charged from the first phase charging date.

Connection site Specific Technical or Economic Conditions

- 10.4 In circumstances where National Grid has identified a wider requirement for development of the transmission system, it may elect to install connection assets of greater size and capacity than the practicable minimum scheme required for a particular connection. In these circumstances, however, connection charges for the party seeking connection will normally be based on the level of connection assets consistent with the practicable minimum scheme needed to meet the applicant's requirements.
- 10.5 There may be cases where there are specific conditions such that the practicable minimum scheme at a site has to be greater than the strict, theoretical interpretation of the standards. In these cases all assets will still be assigned to connection and connection charges levied.
- 10.6 A practicable minimum scheme is considered in terms of the system as a whole and may include a change in voltage level.

Glossary

The following definitions are intended to assist the reader's understanding of this document. In the event of conflict with definitions given elsewhere, those used in the Electricity Act 1989 (as amended by the Utilities Act 2000), Transmission Licence, Grid Code, Balancing and Settlement Code and Connection and Use of System Code take precedence.

Act	The Electricity Act 1989
Authority	The Gas & Electricity Markets Authority (Ofgem)
Balancing and Settlement Code (BSC)	As defined in the Transmission Licence
Bilateral Agreement	Means, in relation to a User, a Bilateral Connection Agreement or a Bilateral Embedded Generation Agreement between National Grid and the User, as defined in Standard Condition 1 of the National Grid Transmission Licence
Charging Date	As defined in the Construction Agreement of the Connection and Use of System Code (CUSC)
Commissioned	In respect of Plant and Apparatus commissioned before the Transfer Date means Plant and Apparatus recognised as having been commissioned according to the commissioning procedures current at the time of commissioning and in respect of Plant and Apparatus commissioned after the Transfer Date] means Plant and/or Apparatus certified by the Independent Engineer as having been commissioned in accordance with the relevant Commissioning Programme
Connection Entry Capacity (CEC)	As defined in the Connection and Use of System Code
Consents	In relation to any Works:- <ul style="list-style-type: none"> a) all such planning and other statutory consents; and b) all wayleaves, easements, rights over or interests in land or any other consent; or for commencement and carrying on of any activity proposed to be undertaken at or from such Works when completed c) permission of any kind as shall be necessary for the construction of the Works
Construction Agreement	An agreement entered into pursuant to Paragraph 1.3.2 of the CUSC
CUSC	The Connection and Use of System Code
Demand	Electricity consumed at sites or by equipment not owned and operated by National Grid

Depreciation Period	In relation to an NGC Asset for a particular User, the period which commences on the asset's initial effective charging date, and which expires after the appropriate duration, which unless otherwise agreed upon connection is 40 years (15 years for FMS Metering Electronics)
Directly-Connected Customer	A large, usually industrial, consumer of electricity who is directly connected to National Grid 's transmission system
Disconnect or Disconnection	<p>(a) permanent physical disconnection of the [User's Equipment] at the site of connection to the Distribution System;</p> <p>(b) permanent physical disconnection of a User's Equipment at any given Connection Site which permits removal thereof from the Connection Site or removal of all National Grid's Assets therefrom (as the case may be);</p> <p>(c) permanent physical disconnection of the User's Equipment or Equipment for which the User is responsible (as defined in Section K of the Balancing and Settlement Code) at the site of connection to the Distribution System</p>
Distribution voltage	A voltage of 132kV or below. Generally taken to be voltages lower than those defined as transmission voltages
Embedded	A direct connection to a Distribution System or the System of any other User to which Users and/or Power Stations are connected
Engineering Charge	As set out in the Statement of Use of System Charges from time to time
Exempt generator	Any generator who, under the terms of the Electricity (Class Exemptions from the Requirement for a Licence) Order 2001, is not obliged to hold a generation licence
Final Sums	As defined in the Construction Agreement
Financial Year	The period of 12 months ending on 31st March in each calendar year
Generator	A person who generates electricity under licence or exemption under the Act
Grid Code	A document prepared by National Grid in accordance with Standard Condition 7 of the Transmission Licence setting out the technical parameters for the operation and use of the transmission system and of plant and apparatus connected to the transmission system
Grid Supply Point (GSP)	A point of delivery from the National Grid Transmission System to a distribution system or Non-Embedded User

Interconnector	Means apparatus, connected to the Total System from or to an External System
Licence standards	Standards listed in Condition AA2 of the Transmission Licence or otherwise registered with the Authority in accordance with which National Grid is required to plan, develop, operate and maintain the transmission system
Licensable Generation	Generating plant where the party generating electricity at that generating plant is required to hold a Generation Licence
Liquidated Damages	The sums specified in the Construction agreement
Mandatory Services Agreement	An agreement between National Grid and a User to govern the provision of and payment for Mandatory Ancillary Services
Modification	Any actual or proposed replacement, renovation, modification, alteration, or construction by or on behalf of a User or National Grid to either that CUSC Party's Plant or Apparatus or the manner of its operation which has or may have a Material Effect on another CUSC Party at a particular Connection Site
National Grid Assets	The Plant and Apparatus owned by National Grid necessary to connect the User's Equipment to the National Grid Transmission System at any particular Connection Site in respect of which National Grid charges Connection Charges (if any) as listed or identified in [Appendix A] to the Bilateral Agreement relating to each such Connection Site
National Grid Transmission System	The system consisting (wholly or mainly) of high voltage electric lines owned or operated by National Grid and used for the transmission of electricity from one Power Station to a substation or to another Power Station or between substations or to or from any External Interconnection and includes any Plant and Apparatus and meters owned or operated by National Grid in connection with the transmission of electricity but does not include any Remote Transmission Assets
Ownership boundary	Shall be the boundary defined by Paragraph 1.7 in this document
Power Station	As defined in the Grid Code as: "an installation comprising one or more Generating Units (even where sited separately) owned and/or controlled by the same Generator, which may be reasonably considered as being managed as one Power Station."

Public Distribution System Operator	Any holder of a distribution licence who was the holder, or is a successor to a company which was the holder of a Public Electricity Supply Licence relating to the distribution activities in England and/or Wales on the CUSC Implementation Date
Reasonable Charges	Reasonable cost reflective charges comparable to charges for similar services obtainable in the open market
Replacement Period	In relation to an NGC Asset, the period commencing on the date on which such NGC Asset is or was originally Commissioned, after which it is assumed for accounting purposes such NGC Asset will need to be replaced, which shall be 40 years unless otherwise agreed between the parties to a Bilateral Agreement and recorded in the relevant Bilateral Agreement
Retail Price Index	<p>Means the general index of retail prices published by the Office for National Statistics each month in respect of all items or:</p> <p>(a) if the said index for any month in any year shall not have been published on or before the last day of the third month after such month such index for such month or months as the parties hereto agree produces as nearly as possible the same result shall be substituted or in default of the parties reaching agreement within six weeks after the last day of such three month period then as determined by a sole Chartered Accountant appointed by agreement by both parties or in the absence of agreement on the application of either party by the President of the Electricity Arbitration Association who shall act as an expert and whose decision shall be final and binding on the parties; or (b) if there is a material change in the basis of the said index, such other index as the parties agree produces as nearly as possible the same result shall be substituted or in default of the parties reaching agreement within six weeks after the occurrence of the material change in the basis of the said index then as determined by the sole Chartered Accountant appointed by agreement by both parties or in the absence of agreement on the application of either party by the President of the Electricity Arbitration Association who shall act as an expert and whose decision shall be final and binding on the parties</p>
Security Standard	National Grid's Transmission System Security and Quality of Supply Standard
Small Power Station	Defined in the Grid Code as: "A Power Station with a Registered Capacity of less than 50MW."
Supplier	A holder of an electricity supply licence

Total System	Has the meaning given to that expression in the Electricity Generation Licence i.e. "...the transmission and distribution systems of all authorised electricity operators which are located in England and/or Wales"
Trading Party	As defined in the Balancing and Settlement Code
Transfer date	31 st March 1990
Transmission Licence	The licence granted to National Grid under Section 6(1)(b) of the Act
Transmission Owner Activity	The function of National Grid's Transmission Business as defined in the Transmission Licence
Transmission system	The system which consists (wholly or mainly) of high voltage lines and electrical plant owned or operated by National Grid and used for the transmission of electricity from one generating station to a substation or to another generating station or between substations or to any Interconnector
Transmission voltage	Voltages above 132kV - usually 275kV and 400kV
User	A party that connects to or makes use of the National Grid Transmission System
Utilities Act 2000	Electricity Act 1989, as amended by Utilities Act 2000

Index to the Statement of the Connection Charging Methodology (Issue 4) Revisions

Issue 4	Modifications	Changes to Pages
Revision 0	New Issue	