

Exemptable Embedded Transmission Generation

Sarah Hall, CISG 6th January 2010



nationalgrid
The power of action.™

Exemptable Embedded Transmission Generators

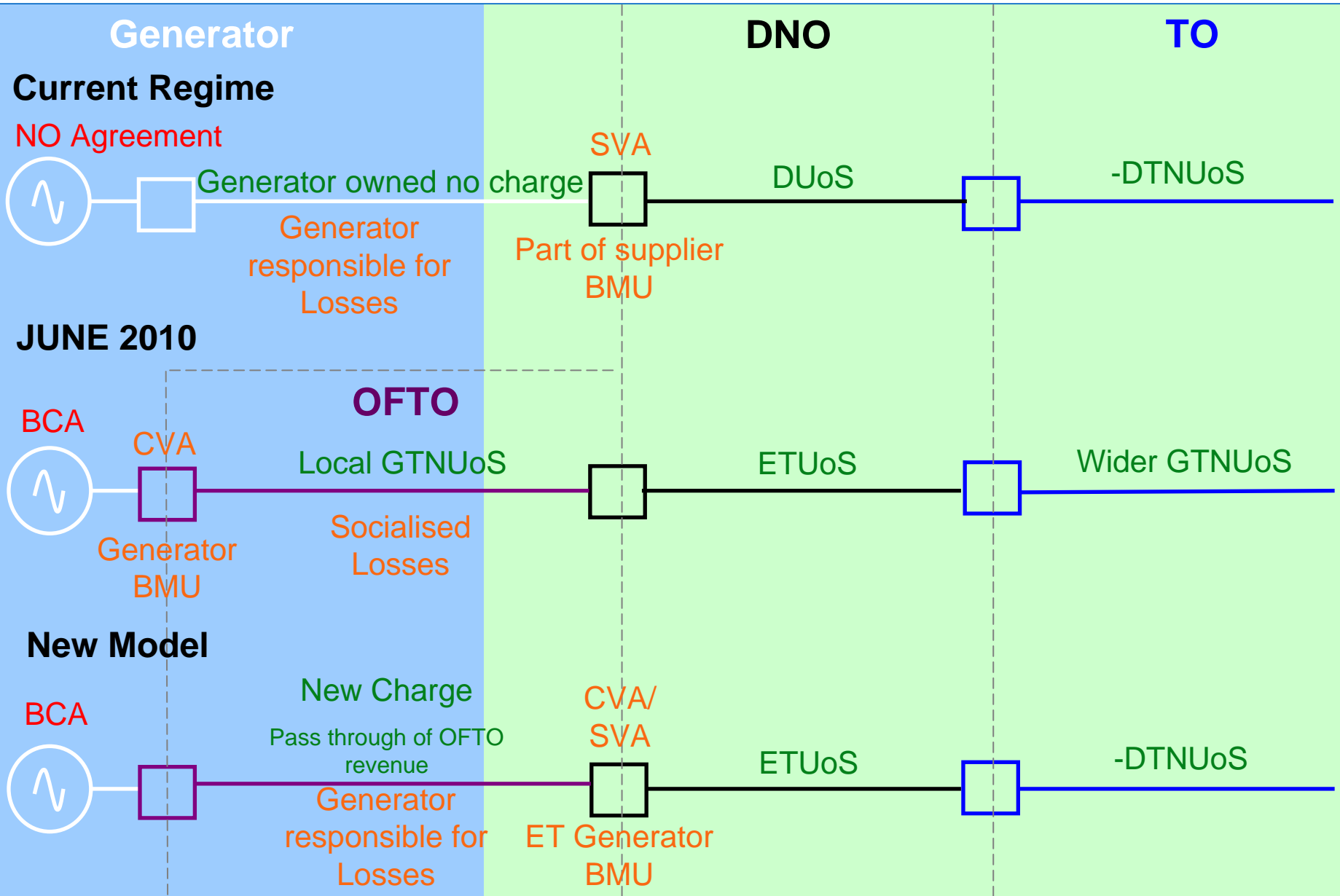

Consultation

- ◆ A consultation on this issue will be published shortly
- ◆ Key Issues:
 - ◆ Would Exemptable Embedded Transmission generators be unduly discriminated against when the new arrangements Go Live?
 - ◆ Should charges for Exemptable Embedded Transmission generators be consistent with directly connected generators or embedded generators?
 - ◆ Should this issue be resolved through a wider review of embedded?