

# **WORKING GROUP REPORT**

## ***Power Park Modules and Synchronous Generating Units Working Group***

**Prepared by the Power Park Modules and  
Synchronous Generating Units Working Group  
for submission to the Grid Code Review Panel**

Reference	PPMSGUWG Report
Issue	1.0
Date of Issue	9 <sup>th</sup> November 2006
Prepared by	PPMSGUWG

**I DOCUMENT CONTROL**

**a National Grid Document Control**

<b>Version</b>	<b>Date</b>	<b>Author</b>	<b>Change Reference</b>
0.1	13/10/06	PPMSGUWG	Initial Draft for Comment by Working Group Members
1.0	09/11/06	PPMSGUWG	Final Draft for GCRP Members

**b Distribution**

<b>Name</b>	<b>Organisation</b>
The Gas and Electricity Markets Authority	Ofgem
Panel Members	Various
National Grid Industry Information Website	

## **II CONTENTS TABLE**

<b>I DOCUMENT CONTROL .....</b>	<b>2</b>
<b>a National Grid Document Control .....</b>	<b>2</b>
<b>b Distribution .....</b>	<b>2</b>
<b>1.0 SUMMARY AND RECOMMENDATIONS .....</b>	<b>4</b>
<b>Executive Summary .....</b>	<b>4</b>
<b>Working Group Recommendation .....</b>	<b>4</b>
<b>2.0 INTRODUCTION .....</b>	<b>5</b>
<b>3.0 PURPOSE AND SCOPE OF WORKING GROUP .....</b>	<b>5</b>
<b>4.0 WORKING GROUP DISCUSSIONS .....</b>	<b>6</b>
<b>5.0 WORKING GROUP RECOMMENDATIONS .....</b>	<b>16</b>
<b>6.0 INITIAL VIEW OF NATIONAL GRID .....</b>	<b>18</b>
<b>7.0 IMPACT ON GRID CODE .....</b>	<b>18</b>
<b>8.0 IMPACT ON INDUSTRY DOCUMENTS .....</b>	<b>18</b>
<b>ANNEX 1 – WORKING GROUP TERMS OF REFERENCE AND MEMBERSHIP .</b>	<b>19</b>
<b>ANNEX 2 – ORIGINAL GCRP PAPER .....</b>	<b>21</b>
<b>ANNEX 3 – SUMMARY OF OUTSTANDING ISSUES .....</b>	<b>23</b>
<b>ANNEX 4 – PROPOSED GRID CODE CHANGES .....</b>	<b>26</b>

## 1.0 SUMMARY AND RECOMMENDATIONS

### Executive Summary

- 1.1 Consultation documents H/04 (Generic Provisions) and SA2004 (Consultation on Technical Requirements for Windfarms) amended the Grid Code to include provisions for the new generation technologies employed in renewable energy schemes.
- 1.2 The Power Park Modules and Synchronous Generating Units Working Group was established in February 2006 with a remit of revisiting specific aspects of the original Generic Provisions Consultation. The Working Group was given the objective of identifying improvements which could be made in light of experience obtained since the introduction of the H/04 and SA2004 provisions in May 2005

### Working Group Recommendation

- 1.3 The Working Group believes that it has satisfied its Terms of Reference and recommends that the Grid Code Review Panel (GCRP) consider the proposed changes contained within this Working Group Report at the November 2006 GCRP meeting.
- 1.4 The Working Group recommends a number of Grid Code changes which may be summarised as follows:
  - i) Relaxation of the fault ride through requirement to allow a conditional power swing in active power recovery
  - ii) Introduction of additional short-circuit fault infeed and mechanical turbine data submissions
  - iii) The provisions for the PPM single line diagram will be amended such that the different equivalents that the User may choose to submit are specified within the Grid Code.
  - iv) Introduction of new provisions which would allow the additional option of continuing to provide voltage control below 20% of Rated MW output.
  - v) CC.7.9 amended such that it clarifies the requirements for manned control points at PPMs in Scotland
  - vi) Introduction of a new Grid Code term (Power Available) and associated provisions
  - vii) Generic functional performance specification to be included into the Grid Code for excitation control systems for Synchronous Generating Units and voltage control systems for Power Park Modules (PPM)
  - viii) Harmonisation of the point of Voltage Control and Reactive Capability across the GB Transmission System
  - ix) Amend the existing Grid Code provisions for Reactive Capability by Embedded Generators such that it allows tripartite discussions to occur on the issues related to the required Power Factors ranges.
  - x) Amendments to the Grid Code definition of 'Power Park Module'
  - xi) CC.A.3.4 amended such that it adopts the existing wording used in the definitions of Primary and High Frequency Response
  - xii) Schedule 5 amended such that the settings for rotor overspeed and underspeed are added to the list of protection settings required for Power Park Units (PPU).
- 1.5 In addition, during the Working Group discussions, members concluded that the issue regarding the applicability of technical requirements to PPM extensions would benefit from further analysis outside the Working Group

discussions, due to the complexity of issues surrounding the matter. It is therefore proposed that this issue is dealt with separately and the matter progressed at a future GCRP meeting.

## **2.0 INTRODUCTION**

2.1 In May 2005, Ofgem approved major changes to the Grid Code resulting from consultations H/04 (Generic Provisions) and SA2004 (Consultation on Technical Requirements for Windfarms). These changes were designed to update the Grid Code to specifically include the new generation technologies employed in renewable energy schemes.

2.2 Since then, the new Grid Code requirements have been successfully applied to projects across Great Britain. However, during this period, a number of detailed practical issues have come to light through liaison with developers and manufacturers that National Grid believe are best addressed through Grid Code changes.

2.3 In November 2005, Econnect held a meeting for the BWEA (British Wind Energy Association) and project developers to discuss their experience with the Grid Code and Bilateral Agreements for connection to the Transmission System. The meeting noted two main areas of concern:

- (a) The dynamic voltage performance requirements being required by National Grid in Bilateral Agreements are significantly in excess of the Grid Code.
- (b) In some cases the reactive capability required on distribution connected Generators can not be used because of constraints in the Distribution Network.

2.4 In response to the issues highlighted by the BWEA, National Grid agreed to consider the inclusion into the Grid Code of the generic technical performance requirements for Voltage Control Systems for PPMs and to investigate if Distribution Network constraints affect reactive capability requirements.

2.5 Generators have previously requested that generic performance requirements for the Excitation Control System for Synchronous Generators are included in the Grid Code. National Grid agreed to consider this proposal and believed that it would be suitable to discuss the issue at the same time as the voltage control requirements for PPMs were discussed.

2.6 At the February GCRP meeting, National Grid presented a paper (Annex 2) outlining the requirement for a formal review of the issues identified by National Grid, the BWEA forum and Generators. The GCRP agreed that a Working Group be formed to review a number of areas where improvements to the Grid Code could be introduced.

## **3.0 PURPOSE AND SCOPE OF WORKING GROUP**

3.1 The paper presented to the GCRP recommended that the Working Group be set up to discuss the following areas where possible improvements may be required to be incorporated within the Grid Code:

- a) Consider the relaxation of the fault ride through requirement to allow a conditional power swing in active power recovery.

- b) Consider improvements to the submission of fault infeed data and some additional mechanical turbine information for system modelling and study purposes.
  - c) Consider the option of allowing voltage control and reactive range capability below 20% active power output.
  - d) Consider redrafting to consistently require manned control points for BELLA power stations where Balancing Codes apply.
  - e) Consider clarification of the applicability of Grid Code requirements to PPM extensions.
  - f) Consider the inclusion of an additional Power Available Monitoring Signal from PPMs required to provide frequency response capability.
  - g) Consider the generic specification of the technical performance requirements of Voltage Control Systems for Power Park Modules and Synchronous Generating Units.
  - h) Consider the harmonisation of the point where voltage control is implemented and the point where the reactive range is delivered to be the connection point.
  - i) Consider the provision of reactive capability by embedded generators
- 3.2 The Terms of Reference (Annex 1) were formally agreed at the first Power Park Modules and Synchronous Generating Units Working Group meeting.
- 3.3 Three further issues were raised once the Working Group had begun its discussions. These were:
- Amending the definition of Power Park Module to reflect the fact that a synchronous plant may be used in future PPMs.
  - Review of Frequency Response/Control Requirements.
  - Amending Schedule 5 Data such that the settings for rotor overspeed and underspeed protection are added to the list of protection settings required for PPU's.

3.4 The Working Group agreed to include discussions on these issues in this remit.

#### **4.0 WORKING GROUP DISCUSSIONS**

4.1 The Working Group debate focused on the areas as outlined in paragraph 3.1. Each issue was taken in turn and discussed fully by the group.

#### **4.2 Relaxation of Fault Ride Through Recovery Requirements**

4.2.1 The Working Group noted that the existing Grid Code clause for fault ride through recovery requires recovery to 90% of the pre-fault level of Active Power. The Working Group discussed and agreed to the proposal which would permit a relaxation of the current provisions to allow subsequent oscillations in output power, provided that the integral of the Active Power output during the oscillations is at least equal to that which would have been

achieved had there been no oscillations and that the oscillations are sufficiently well damped.

#### 4.3 Fault Infeed and Turbine Data

4.3.1 The Working Group acknowledged that wind farms use different technologies compared to Synchronous Generators and consequently additional data is required from the generator at the time of application to allow National Grid to conduct the relevant studies.

4.3.2 The Working Group noted that one such additional data requirement stems from the need to model torsional oscillations on wind turbines. The Working Group discussed the different type of models available and the appropriateness of each type. It was agreed that a two mass model would be required for network studies: one mass representing the generator and the other mass for other aspects of the apparatus e.g. blades, turbines etc. The Working Group agreed the need of flexibility within the Grid Code provisions to allow the most appropriate 2-mass model to be developed by manufacturers.

4.3.3 The Working Group noted that at the time of application the User does not always know what turbine type is going to be used and therefore the relevant data is not always available to be submitted to National Grid. The Working Group were informed that this scenario is not necessarily restricted to wind turbines and is dealt with by the commercial framework i.e. the relevant Bilateral Agreement can be altered as and when more reliable information becomes available.

4.3.4 The Working Group were informed that a number of additional parameters were required to model wind turbines e.g. gear box ratio, number of pole pairs. The submission of the majority of these data items would be on a one off basis i.e. at the time of application for a CUSC contract. However it was acknowledged that certain data streams would be required to be provided on an annual basis as part of the Week 24 submissions.

4.3.5 The Working Group noted that Average Site Air Density information would be a new data submission for PPMs which would be provided from an acceptable source e.g. Met Office Data. National Grid informed the group that the developers were best placed to provide the air density data. It would be too complex a task for National Grid to independently acquire data for each PPM due to the numbers of PPMs scheduled or planning to connect in Great Britain.

4.3.6 The Working Group discussed whether the Grid Code should specify the year for which the data should be submitted e.g. forecast or historic or whether this should be a choice made by the developer. National Grid proposed that the User should be free to choose the year and state in the data submission which year was selected.

4.3.7 The detailed legal drafting to codify these proposals developed by National Grid and incorporating the views of the Working Group can be found in Annex 4.

#### *User System Layout*

4.3.8 The Working Group was informed that the requirements of the single line diagram containing equivalents that the User may choose to submit will be

made specific under the proposed changes. The requirements will be aligned with the proposed requirements for the submission of short circuit infeed data.

*Short Circuit Infeed Data*

- 4.3.9 National Grid put forward proposals for the submission of short circuit infeed data for PPMs. These require the submission of data both at the Grid Entry Point and within the PPM network, for a number of fault conditions, at a number of time intervals.
- 4.3.10 The Working Group questioned the need for this data, which is in excess of similar provisions for Synchronous Generators Units/Auxiliaries. The Working Group was informed that the Transmission Owners and Operators are required to undertake assessments of short circuit levels across the Transmission System. The accuracy of such assessments is essential to ensure the safety of staff, the public and to meet the requirements of the Health and Safety Act. This means that sources of fault infeed must be accurately modelled.
- 4.3.11 National Grid noted that the infeed from Synchronous Generating Units, including its variation with time, can be predicted, according to internationally agreed standards and procedures, from a number of data items submitted as part of week 24 data e.g. machine and transformer reactances. By using this data and the standards, models for use in studies can be constructed.
- 4.3.12 However the infeed from PPMs is not solely dependent on physical parameters such as impedances. It may be significantly affected by the action of electronically controlled protection devices. The action of these devices and the time in which they act, depends on a number of factors, some of which may be site specific. This means that their action is difficult to predict. There are currently no standards on how to model wind turbines under fault conditions. National Grid therefore believes that for this reason, data is required that demonstrates the infeed, including any action by protective devices, under the range of conditions and across the whole time range that need to be assessed. Data is also required that describes the limiting conditions under which the protection will act.
- 4.3.13 The standards used for assessing short circuit levels allow for different levels of detail to be modelled according to the proximity to a short circuit. This will mean that the level of detail of the wind farm that needs to be studied will vary. For this reason infeed data is requested at both the connection point and within the wind farm network.
- 4.3.14 National Grid did acknowledge that submission of this data constitutes a greater requirement than for synchronous plant. However, National Grid reiterated that in order to ensure that short circuit assessments are carried out accurately under all practical circumstances a complete model of the behaviour of plant is required.
- 4.3.15 The Working Group highlighted that a significant amount of the information being required by National Grid would not be available at the time when the connection offer was being made. National Grid agreed that a distinction would be made between the detailed and standard planning data with the intention that only the information that would be expected to be known at the time of application for a CUSC Contract would be required to be submitted.

4.3.16 The detailed legal drafting to codify these proposals developed by National Grid and incorporating the views of the Working Group can be found in Annex 4.

#### 4.4 Voltage Control and Reactive Range Capability below 20% Active Power Output

4.4.1 The Working Group discussed the proposals which would allow an additional option to continue to provide voltage control below 20% of Rated MW output. The Working Group agreed that this proposal would provide additional flexibility for Users and would be of benefit to the Transmission and/or Distribution System to which it is connected.

4.4.2 The proposed amended provision will not specify the reactive capability required if voltage control is offered below 20% Rated MW. The Working Group noted that the existing requirements that the Generators should be able to supply zero MVAr within a tolerance will continue to apply.

#### 4.5 Manned Control Points

4.5.1 The Working Group were informed that where Balancing Codes 1 and 2 apply to a BELLA (Bilateral Embedded Licence exemptable Large power station Agreement), it requires the power station to be able to respond to control instructions and therefore implies a continuously manned control point. However CC.7.9 of the Grid Code requires Embedded Exemptable Large Power Stations in SHETL's area to have a manned control point between 0800 and 1800 hours only. This inconsistency needs to be addressed such that CC.7.9 reflects the BC2 provisions.

4.5.2 The Working Group were informed that the 'manned control point' may not be in the traditional form but could be a contact point appropriately located by the generator so that instructions can be received and acted on.

4.5.3 A Working Group member queried what the associated MW threshold level would be. The Working Group agreed that the threshold should reflect the amended levels introduced by B/06 (Regional Differences).

4.5.4 After further review, National Grid notes that the stated MW threshold level is not aligned to associated levels for Small, Medium and Large Power Stations. Therefore to avoid any unnecessary ambiguity, National Grid proposes to remove the reference to the MW threshold level from CC.7.9.

4.5.5 The detailed legal drafting to codify these proposals developed by National Grid and incorporating the views of the Working Group can be found in Annex 4.

#### 4.6 Power Park Modules Extensions

4.6.1 The Working Group discussed what technical requirements would apply to a PPM which was constructed prior to the approval of Grid Code Consultation Document H/04 (Generic Provisions) and was being extended in size.

4.6.2 In particular there were discussions on the applicability of conditions dependent on whether a PPM was small, medium or large when a change to the Rated MW caused a consequential change in category. The Working Group noted that this was also an issue for synchronous plants.

4.6.3 As a result of these discussions, National Grid proposed that this matter should be considered separately. The Working Group agreed with this proposal. This issue will be taken forward separately through the GCRP at a suitable time in the future.

#### 4.7 Power Available Monitoring Signal

4.7.1 The Working Group discussed proposals that a 'Power Available' (P-Available) signal is provided in addition to wind speed. The 'Power Available' would indicate the maximum possible power output of the PPM based on the turbines in service and the prevailing wind speed. National Grid could use this signal to indicate the amount of reserve currently being held by the PPM.

4.7.2 The Working Group queried the difference between P-Available and MEL (Maximum Exporting Level). The Working Group was informed that the P-Available will be used purely for system operation purposes whilst MEL is a contractual position. MEL would continue to set the contractual requirement for the provision of frequency response service and National Grid has no intention of replacing MEL with P-Available. P-Available will be purely an operational tool used to manage the system more effectively.

4.7.3 The Working Group noted that MEL and P-Available will be derived from the same data source. However, in National Grid's view it was not practical to constantly update MEL due to the IS systems that are in place. In the event of P-Available deviating too far from MEL, MEL should be updated to reflect the value of P-Available.

4.7.4 The Working Group discussed the differences between P-Available and 'Potential MW Available' which is already provided by Users. The Working Group noted that 'Potential MW Available' usually equates to the installed capacity of a PPM which may be reduced during turbine outages or restrictions. The Working Group was informed that 'Potential MW Available' is independent of the prevailing wind speed which is the difference between the 'Potential MW Available' and P-Available. The Working Group agreed that it would be beneficial if the P-Available provisions did not interact with 'Potential MW Available'.

4.7.5 The detailed legal drafting to codify these proposals developed by National Grid and incorporating the views of the Working Group can be found in Annex 4.

#### 4.8 Excitation Control System for Synchronous Generating Units

4.8.1 The Working Group was informed that since 1990, the functional performance requirements for Synchronous Generating Units Excitation Control System have been specified in the Bilateral Agreement. It is now proposed to include the generic parts of these specifications within the Grid Code in order to assist with transparency in this area.

4.8.2 The Working Group noted that not all of the specifications were generic and that there would continue to be an element of site specificity which would be reflected in the Bilateral Agreements. In such cases typical ranges for the values would be indicated in the Grid Code. Working Group members requested that the ranges reflect the full possibility of values that National Grid can foresee rather than those used currently.

4.8.3 The Working Group discussed the various mechanisms through which the generic elements would be included within the Grid Code:

Option 1 – introduce new Connection Condition Appendix which would include sample text that reflects existing Bilateral Agreements

Option 2 - separate document which would sit outside the Grid Code but contain all variables

4.8.4 The Working Group noted that Option 2 would not have any official governance and would therefore be difficult to enforce. Therefore Option 1 is the preferred choice.

4.8.5 The Working Group were informed that in addition to the wordings currently specified in the Bilateral Agreement, there would be a new requirement which will specify that over-excitation limiters should not limit the plant performance more than is necessary to keep it within design limits. This requirement is based on international experience of recent blackouts and National Grid studies that show the action of over-excitation limiters is a major factor in determining whether voltage collapse occurs on highly stressed networks.

4.8.6 The Working Group were informed of the proposal to amend the current definition of Automatic Voltage Regulator (AVR) such that it is aligned with BS EN 60034-16-1:1996 and IEC 34-16-1:1991. The Working Group agreed that it would be useful for the new definition of AVR to still retain its reference to the control of terminal voltage which is not covered by the industry standards.

4.8.7 The Working Group discussed when the provisions should apply from and whether they should be applicable to all Users. The consensus of the Working Group was for the provisions to be applicable to all Users newly connecting and to existing Users making changes to the excitation system.

4.8.8 The detailed legal drafting to codify these proposals developed by National Grid and incorporating the views of the Working Group can be found in Annex 4.

#### 4.9 Voltage Control Systems for Power Park Modules

4.9.1 The Working Group members highlighted a number of practical issues faced by developers in achieving Grid Code compliance based on existing Bilateral Agreements, particularly in respect of the point of voltage control.

4.9.2 A Working Group member indicated that developers had built a system that they believed to be Grid Code compliant. However, after reviewing the conditions within the Bilateral Agreement they could not comply with National Grid's interpretation of compliance as enshrined in the Bilateral Agreements. The Working Group was informed that historically developers have expended time, effort and money working with manufacturers to adapt their equipment to meet Grid Code requirements. However this was now more difficult due to the emergence of markets in the USA and China which offer a more attractive commercial environment to manufacturers.

4.9.3 National Grid informed the group that this was not the viewpoint obtained from manufacturers when Generic Provisions was being developed, as the manufacturers viewed the UK market as being crucial. From a National Grid perspective, the security and stability of the system is paramount and this underpins the basis of any requirements regarding this issue.

- 4.9.4 A Working Group member indicated the real issue was the lack of transparency/understanding of the true intention of the existing Grid Code provisions. National Grid's view of the Grid Code requirements (as stated in the Bilateral Agreement) was an interpretation which differed somewhat from that of the developers. Disputes could arise from the ambiguities in the Grid Code provisions.
- 4.9.5 National Grid stated that it would be important and beneficial to bring forward changes that maximise the clarity and visibility of the requirements in order to minimise any risk of differing interpretations.
- 4.9.6 National Grid indicated that the proposals it has developed (as detailed in Annex 4) will seek to remove ambiguity of interpretation that arises from the specification of point of voltage control in CC.6.3.8(c) and to clarify that whilst the control point is specified, the measurement point and location of voltage control system elements including any reactive compensation plant will be selectable by the User. In addition the proposal would eliminate the need for producing different specifications at different sites according to the number of circuits and transformers between a different User chosen control point and the Transmission System.
- 4.9.7 National Grid outlined the voltage control proposals which divide the requirement into two areas: steady state and transient voltage control.
- 4.9.8 The steady state requirement is based on National Grid's licence standards that require steady state studies to be undertaken immediately prior to an event and then 5 seconds after an event. In the conditions studied after 5 seconds adjustments to controls, such as the adjustment of a slope characteristic, should not occur. Studies of the slope characteristic and setpoint (which is proposed to be a newly defined term meaning the voltage at which 0 MVARs are generated) of a wind farm using terminal voltage control show that they can vary significantly with MW generation and could be much higher than those seen at the High Voltage (HV) side of a Synchronous Generating Unit transformer. Slopes at this level are too high to ensure that all of the MVAR capability can be utilised at acceptable transmission voltages and therefore implies that correction is necessary. Due to the 5 second requirement of the security standards, correction within a similar period is required.
- 4.9.9 The proposal therefore requires correction of a slope to a specified level (typically 4%) in a 5 second period. This does not rule out the use of a SCADA system that introduces a delay of up to 5 seconds, which National Grid understands from discussions is one of the major concerns for developers arising from current Bilateral Agreements that only refer to 1 second responses.
- 4.9.10 The transient period covers the time from an event on the system up to 5 seconds after the event when the transient oscillations will have died out. In this period the requirement is to produce a reactive power response at a rate such that 90% of the capability can be utilised within 1 second if the event is such that this size of response is needed. During this transient period there is no specification of either the setpoint or slope. The Working Group noted that the slope characteristic introduced by the wind farm network is significantly reduced under transient conditions, meaning that it is likely that the connection point transient requirement can be met by monitoring and switching compensation at a point within the wind farm network. As the

system settles following a disturbance a slope will be introduced. The requirements of the slope are covered by the steady state requirement.

*Speed of Voltage Control Justification*

- 4.9.11 National Grid circulated to the Working Group the findings of a National Grid study carried out to determine the required transient response rate.
- 4.9.12 The study aimed to identify the type of contingency that would necessitate a 1 second response rate, whether or not the contingency would be credible and highlight any implications of an insufficient response.
- 4.9.13 The study showed that for a credible fault some distance from the wind farm within a large network, a one second response is necessary to prevent widespread voltage collapse and the loss of the wind farm. The location of the fault was sufficiently far from the wind farm that several wind farms could be affected, resulting in a large loss of generation if the voltage control response is insufficient.
- 4.9.14 National Grid conducted an additional study to consider the nature of the required response e.g. step response, continuous. In this study all of the MVArS available at the terminals were fully switched in when the terminal voltage reached 0.6. This occurred in less than one second but did not prevent voltage collapse. This study indicated that for system security it is not sufficient to meet the Grid Code requirement by providing a step response at one second. Further studies indicated that for the studied network and event, a 600 ms switching time would be needed for a step response to maintain security. This time will vary according to the wind farm and network and hence is site specific. Any specification in the Grid Code of the performance requirements necessary for a step response will need to be generic and therefore reflect the most onerous requirement. National Grid believes that specifying that the response should be progressive is more suitable.
- 4.9.15 National Grid highlighted that the study also demonstrated that with a suitable control system the transient response requirement of the proposal can be met by controlling a point within the PPM. However, this controller would not be able to meet the steady state response at the Connection Point.
- 4.9.16 The detailed legal drafting to codify these proposals developed by National Grid and incorporating the views of the Working Group can be found in Annex 4.

4.10 Harmonisation of Point of Voltage Control and Point of Reactive Capability

- 4.10.1 The Working Group discussed the Reactive Power capability requirement in Scotland. At present the requirements may mean that the PPM is required to provide a capability at the HV side of a transformer that it does not own. The proposal would harmonise the point of provisions of Reactive Capability and the point of voltage control to be the Grid Entry Point or User System Entry Point.
- 4.10.2 A Working Group member highlighted that the ownership of the generating unit transformer determines whether there would be a relaxation in the provisions for Scotland. The Working Group member stated that this change might mean that in practice, if the Generator owns the transformer, there would be no relaxation in Scotland although the requirement becomes aligned to that of England and Wales. This would need to be highlighted in any associated Consultation Document.

- 4.10.3 National Grid stated that this proposal on reactive capability is indeed in practice a relaxation should the transformer be owned by the TO because the capacitive reactive capability is reduced due to the fact that the generator no longer has to supply the 132/33kV reactive power losses.
- 4.11 Provision of Reactive Capability by Embedded Generators
- 4.11.1 The Working Group was informed by Generators that in some cases the steady state Reactive Capability required on distribution connected Generators cannot be utilised because of constraints in the Distribution Network. This may result in unnecessary investment by developers.
- 4.11.2 A Working Group member indicated that the issue was not always caused by limitations by the DNO network but with interactions with other customers. It was also noted that dispatch of Mvar cannot be done without the sanction and coordination of the applicable DNO.
- 4.11.3 It was noted that certain DNOs ask for Power Factors to be adhered to rather than operating within a reactive range. A Working Group member stated that the reactive capability would still be required to be delivered in transient timescales to assist in distribution network voltage control. The unity Power Factor control is slow acting and is only a steady state requirement. Another Working Group member indicated that it would be possible to provide the Reactive Power requirement transiently but not on a continuous basis. National Grid suggested that it may be acceptable to restrict the steady state provision of reactive power in some cases but the transient provision of the full capability will always be beneficial.
- 4.11.4 The Working Group agreed that obtaining the DNO views of their existing and emerging needs and hence policy for the management of reactive power and voltage control in their networks would be important before developing any modifications to the Grid Code.
- 4.11.5 A DNO representative acknowledged that historically this was not an issue that the DNOs were concerned about. The Working Group noted that DNOs do not support their systems with generation and because of the need to provide a statutory voltage through P2/6 contingencies, voltage control has generally been provided for planning purposes entirely from network assets. It was acknowledged that going forward this might change. In the short term this can be dealt with on a bilateral basis, much as P2/6 compliance considerations might have to be. Longer term there will be an argument for codifying generic issues in the Distribution Code.
- 4.11.6 The Working Group discussed the matter in-depth using relevant examples and highlighted four possible resolutions:
1. Status quo – Generators continue to meet Grid Code requirements;
  2. Modification to Grid Code to allow tripartite discussions between National Grid, DNO and Generator on the issues surrounding the required Power Factor range for an embedded power station (may have to be quadripartite in Scotland to reflect the TOs);
  3. Modification to Grid Code to allow DNO to apply its own requirements to embedded Medium Power Station (or embedded Large Power Station or both), with no reference to National Grid;

4. Review the whole operation of DNO Networks, technically and commercially, to resolve this issue in a new framework, including the possible trading of reactive power across DNOs' systems.
- 4.11.7 It was noted that option 4 was completely out of scope for the current Working Group and would not be considered any further.
- 4.11.8 The Working Group discussed the possibility of modifying the Grid Code to allow tripartite discussions to occur between National Grid, DNO and Generator on the actual required Power Factor range for an Embedded Medium Power Station which would form part of the Bilateral Agreement between the DNO and the User. It was acknowledged that this discussion might be quadripartite in Scotland, to take account of the Scottish Transmission Owners.
- 4.11.9 The issue of stranded assets was discussed by the Working Group. The Working Group were informed that the steady state reactive capability required on distribution connected Generators cannot be classified as stranded assets as the Reactive Capability would be fully utilised under transient conditions to assist in distribution network voltage control.
- 4.11.10 National Grid informed the Working Group that the transient requirements are not mentioned specifically within the Grid Code as the steady state requirements are delivered in transient timescales hence the transient requirements are implied via the requirements for steady state provision of Reactive Power.
- 4.11.11 National Grid confirmed that the inability of a generator to supply Reactive Power within the DNO Network due to DNO Network limitations would not impact the Generators' compliance with the Grid Code regarding their Reactive Power capability. It was further confirmed that currently there is no obligation on the DNOs to upgrade their network to facilitate delivery of such Grid Code capability.
- 4.11.12 The proposals are based on option 2 and allow for the voltage control provisions for PPMs to be replaced in Bilateral Agreements with requirements that include the provision of reactive power within a restricted range in steady state conditions.
- 4.11.13 The current provisions concerning the despatch of reactive power for Synchronous Generators (BC2.A.2.6) allow the despatch of a MVAR target that takes account of network restrictions. The provisions also allow for an agreement whereby the Generator will return to this despatched value following a system disturbance.
- 4.12 Cross Referencing for Licence Exempt Embedded Medium Power Stations (LEEMPS) Provisions
- 4.12.1 A Working Group member questioned the applicability of the proposed new provisions under the LEEMPS provisions. The Working Group agreed that it was important that the new provisions are adequately incorporated within the LEEMPS existing arrangements which were introduced and implemented by Grid Code Consultation Document D/05.
- 4.12.2 It is therefore proposed that PC.3.3 and CC.3.4 are updated accordingly such that they are reflective of the proposals outlined in this Working Group report. The update includes requiring the provision of the single line diagram of

PC.A.2.2.2 as this diagram will now be linked to the submission of fault infeed data.

#### **4.13 Other Proposals**

4.13.1 The Working Group discussed other proposals which were not initially specified in the Working Group's Terms of Reference but had been highlighted and accepted as potential areas of review:

- Definition of Power Park Module
- Frequency Response/Control
- Schedule 5 Data

##### 4.13.2 Definition of Power Park Modules

The Working Group discussed the proposal to amend the definition of Power Park Modules and agreed to update the definition to reflect the fact that a synchronous plant may be used in future PPMs. The proposal is to remove the term 'Non-Synchronous' from the definition. The definition will still require an intermittent power source and will therefore still not apply to a conventional plant.

##### 4.13.3 Frequency Response/Control

In response to the request from some members, the Grid Code Frequency Response requirements were reviewed by National Grid to address the issues raised which were mainly associated with the initial response performance of PPMs following large frequency disturbances.

4.13.4 The nature of the proposals was mainly to clarify rather than change the requirements. It was agreed that some of the existing wordings in the Glossary and Definitions for Primary and High Frequency Responses could be adopted in CC.A.3.4 to help the plant developers/suppliers to focus on the issue.

4.13.5 It was accepted that there will always be an inherent delay with any type of generating plant but appropriate control measures helped to minimise such a delay. This has been adopted successfully by the industry in the past and National Grid believes similar technical performances should be achievable on PPUs and PPMs.

4.13.6 The droop requirements on PPUs and PPMs were discussed and proposals to clarify the requirements with variation in the number of PPUs in service were agreed.

4.13.7 The detailed legal drafting to codify these proposals developed by National Grid and incorporating the views of the Working Group can be found in Annex 4.

##### 4.13.8 Schedule 5 Data

The Working Group discussed and agreed to the proposal of adding the settings for rotor overspeed and underspeed protection to the list of protection settings required for PPUs in Schedule 5.

#### **5.0 WORKING GROUP RECOMMENDATIONS**

5.1 The Working Group believes that the changes contained in this report :

- will improve clarity on the requirements that new plant employing non-synchronous generation technologies are obliged to meet;
- refine existing provisions to reflect current experience of the technical capabilities of the emerging technologies;
- introduce generic specifications for some items of synchronous generating plant performance;
- constitute a number of relaxations of technical requirements for emerging technologies.

5.2 In summary the recommended changes are :

- 5.2.1 The introduction of additional provisions which would result in a relaxation of fault ride through recovery requirements to allow a conditional power swing in Active Power Recovery.
- 5.2.2 It is proposed to introduce the requirement to submit additional data that will be used by National Grid to undertake system studies. The data streams will be submitted by the developer at the time of application for a CUSC contract and will form part of the Week 24 submission where applicable.
- 5.2.3 The provisions for the PPM single line diagram, provided by Users to describe their network, will be amended such that the different equivalents that the User may choose to submit are specified within the Grid Code.
- 5.2.4 It is recommended to introduce new provisions regarding the submission of short circuit infeed data. The data is required to make accurate assessments of short circuit levels across the Transmission System. It is acknowledged that this provision constitutes a greater data requirement for PPM compared to equivalent Synchronous Generating Units.
- 5.2.5 It is proposed to introduce provisions which would allow an additional option of continuing to provide voltage control below 20% of Rated MW output.
- 5.2.6 It is proposed to amend CC.7.9 such that it clarifies the requirements for manned control points at Power Park Modules in Scotland.
- 5.2.7 The proposals that would outline the technical requirements that would apply to a PPM (constructed prior to the implement of H/04 provisions) extension will be reviewed at a later date by National Grid and the GCRP and consequently no changes regarding this issue will be brought forward under this review.
- 5.2.8 It is recommended to introduce a new Grid Code term ('Power Available') and associated provisions. The new term would indicate the maximum possible output of the PPM based on the turbines in service and the prevailing wind speed.
- 5.2.9 It is proposed that the generic requirements for functional performance of the excitation systems of Synchronous Generating Units will be included in the Grid Code rather than specified in the Bilateral Agreements. This will increase transparency in this area of the Grid Code. It is also proposed to introduce similar agreements for PPMs regarding the specification for Voltage Control System.
- 5.2.10 It is recommended that the point of Voltage Control and Reactive Capability is harmonised across the GB Transmission System.

- 5.2.11 It is proposed to amend the existing Grid Code provisions for Reactive Capability by Embedded Generators such that it allows tripartite discussions to occur on the required Power Factors ranges.
- 5.2.12 It is recommended that a new Grid Code definition for 'Power Park Module' be introduced. The amended definition will reflect the fact that a synchronous plant may be used in future PPMs.
- 5.2.13 The existing wording in the definitions of Primary and High Frequency Response to be adopted in CC.A.3.4 to clarify the frequency response requirements for PPM following large frequency disturbances.
- 5.2.14 Existing Grid Code Schedule 5 be amended such that the settings for rotor overspeed and underspeed is added to the list of protection settings required for PPU's.
- 5.3 The recommendations are based on the consensus of opinions following extensive Working Group discussions. In some areas, it has not been possible to reach a position that all parties agree with, these areas are summarised in Annex 3. The summary includes any differing views from those presented in the recommendations and National Grid's reasons for not amending the proposals.

## **6.0 INITIAL VIEW OF NATIONAL GRID**

- 6.1 National Grid agrees with the Working Group recommendations. Pending discussion at the Grid Code Review Panel of this Working Group Report National Grid intends to consult with Authorised Electricity Operators on making changes to the Grid Code in line with the Working Group recommendations contained in this report.

## **7.0 IMPACT ON GRID CODE**

- 7.1 The proposed changes require amendments to the following Grid Code sections:
- i. Glossary and Definitions
  - ii. Planning Code
  - iii. Connection Conditions (this includes the introduction of two new Appendices)
  - iv. Balancing Code 2
  - v. Data Registration Code

- 7.2 The associated legal text for the Working Group recommendations is outlined in Annex 4.

## **8.0 IMPACT ON INDUSTRY DOCUMENTS**

### **Impact on Core Industry Documents**

- 8.1 None.

### **Impact on other Industry Documents**

- 8.2 None.

## **Annex 1 – Working Group Terms of Reference and Membership**

### **Grid Code Working Group Power Park Modules and Synchronous Generating Units Terms of Reference**

#### **Objectives**

A paper was presented to the February GCRP highlighting a number of Grid Code related issues that GCRP members agreed need re-considering in the light of experience. The GCRP recommended establishing this working group. The objective of the group is to discuss the issues and proposals under 'Scope of Work' and agree a way forward regarding possible modifications to the Grid Code.

#### **Membership**

The membership of the working group will be drawn from the GCRP or their nominated representatives, the Relevant Transmission Licensees and Ofgem.

#### **Scope of Work**

The group will consider the following issues, as agreed by the GCRP:

- (a) Consider the relaxation of the fault ride through requirement to allow a conditional power swing in active power recovery.
- (b) Consider improvements to the submission of fault infeed data and some additional mechanical turbine information for system modelling and study purposes.
- (c) Consider the option of allowing voltage control and reactive range capability below 20% active power output.
- (d) Consider redrafting to consistently require manned control points for BELLA power stations where Balancing Codes apply.
- (e) Consider clarification of the applicability of Grid Code requirements to Power Park Module extensions.
- (f) Consider the inclusion of an additional Power Available Monitoring Signal from Power Park Modules required to provide frequency response capability.
- (g) Consider the generic specification of the technical performance requirements of Voltage Control Systems for Power Park Modules and Synchronous Generating Units
- (h) Consider the harmonisation of the point where voltage control is implemented and the point where the reactive range is delivered to be the connection point.
- (i) Consider the provision of reactive capability by embedded generators

#### **Deliverables**

National Grid will produce:

- a GCRP paper recommending a way forward on the above issues, taking into account the group discussions
- draft legal text of any proposed Grid Code changes

#### **Timescales**

The working group will aim to complete its work for the GCRP meeting that it is to take place in September 2006.

## MEMBERSHIP

The Working Group has the following members:

Chair	Mark Duffield
National Grid	William Hung/Helge Urdal Mark Perry Nasser Tleis Brian Taylor
Industry Representatives	Neil Sandison (Scottish & Southern Electricity) Simon Cowdroy (Econnect) Claire Maxim (E.ON) John Norbury (RWE) Mike Kay (United Utilities) Damien McCool (Scottish Power) Hamish Dallachy (Scottish Power) Lindsay McGrow/David Gardner (Scottish & Southern Electricity) Philip Belben (E.ON) Tim Moore (EDF Energy) John Gaffney (RWE) David Ward (Magnox)
Authority Representative	Bridget Morgan
Technical Secretary	Lilian Macleod

## **Annex 2 – Original GCRP Paper**

### **Grid Code Review Panel**

#### **Grid Code Modifications for Power Park Modules**

##### **Introduction**

1. In May 2005, Ofgem approved major changes to the Grid Code resulting from consultations H/04 and SA2004. These changes were designed to update the Grid Code to specifically include the new generation technologies employed in renewable energy schemes. Since then, the new Grid Code requirements have been successfully applied to projects across Great Britain. However, during this period, a number of detailed practical issues have come to light through liaison with developers and manufacturers.
2. On 23 November 2005 Econnect held a meeting for the BWEA and project developers to discuss their experience with the Grid Code and Bilateral Agreements for connection to the Transmission System. The notes of this meeting were circulated to GCRP members, Ofgem and others in National Grid.
3. This paper has been prepared by National Grid to present a list of issues to be addressed where National Grid believes the Grid Code might be improved.

##### **Background**

4. Since May 2005, National Grid has identified a number of areas where improvements to the Grid Code should be made in the light of experience. In summary these are:
  - (a) Harmonisation of the point where voltage control is implemented and the point where the reactive range is delivered to be the connection point. This will mean a relaxation of the reactive range requirements for some directly connected generators in Scotland.
  - (b) Relaxation of the fault ride through requirement to allow a conditional power swing in active power recovery.
  - (c) Improvements to the submission of fault infeed Data and some additional mechanical turbine information for modelling and study purposes.
  - (d) Additional option to allow voltage control and reactive range capability below 20% active power output.
  - (e) Redrafting to consistently require manned control points at BELLA power stations where Balancing Codes apply.
  - (f) Clarification of the applicability of Grid Code requirements to Power Park Module extensions
  - (g) Inclusion of an additional Power Available Monitoring Signal from Power Park Modules required to provide frequency response capability.
5. In addition, the meeting chaired by Econnect noted two main areas of concern for the BWEA:
  - (a) The first is that the BWEA believe that the dynamic voltage performance requirements being required by National Grid in Bilateral Agreements are significantly in excess of the Grid Code.
  - (b) The second is that the BWEA believe that in some cases the reactive capability required on distribution connected generators can not be used because of constraints in the Distribution Network.

6. Regarding issue (5a), whilst National Grid agrees that the dynamic voltage performance requirements are not specified in the Grid Code, such specification in the Bilateral Agreements is fully consistent with the Grid Code and this is clearly stated in the Grid Code. This is also consistent with the practice with synchronous generators since 1990. However, National Grid proposes adding to the list under (4) above a parallel piece of work it began recently aimed at proposing the inclusion into the Grid Code of the generic technical performance requirements for Excitation Control Systems for synchronous generators and Voltage Control Systems for Power Park Modules.

### **Way Forward**

7. National Grid believes that there are two options for progressing the above issues. These are:
  - (a) GCRP members may submit comments and/or proposals on the above issues to National Grid. Following consideration of these comments/proposals, National will bring forward proposals to the GCRP at its May meeting
  - (b) A sub-group comprising GCRP members or their nominees is formed to discuss the issues. National Grid would then bring forward proposals to the GCRP at its May meeting
8. Regarding the second concern of the BWEA, (5b), National Grid does not believe that this is an issue unique to renewable generation projects but is a more fundamental question relating to the division of responsibilities set up at privatisation. While National Grid is happy to discuss the provision of reactive capability on embedded generators, this can not be done in isolation from the Distribution Code Review Panel. This issue may therefore be progressed by a joint GCRP/DCRP sub-group since this would allow the DCRP to consider their requirements in this field.

### **Recommendation**

9. The Grid Code Review Panel is invited to discuss these issues and agree the way forward including the timescale for bringing back proposals to the GCRP.

### Annex 3 – Summary of Outstanding Issues

The table below summarises the areas in which NGET believe there are outstanding issues at the time of circulation of this report. These issues are in areas in which the working group has not reached a consensus.

Area of issue	Comments	NGET response
Submission of short circuit infeed data	RWE propose that a subset of the full data is submitted if actual data is not available. They also propose that the main data submission should be DPD and that this only needs to be submitted if NGET identify an issue.	The proposal to submit a subset of the full data has been introduced into the legal text. The requirement to always submit full data when it is available has been retained to ensure efficient investment in the transmission system. The data has been kept as SPD to maintain consistency with other fault data requirements.
Provision of voltage control below 20% rated MW output	Econnect would like CC6.3.2 modifying to reflect the revised requirements	Changes have been made to CC.6.3.8 to reflect the proposal. Changing CC6.3.2 will mean reactive limits will have to be specified, the aim is to allow voltage control within any reactive range available.
Harmonisation of voltage control point and the point of the reactive capability requirement	SPT may not support the proposal as it will result in a reduction in the reactive capability available to the transmission network for some future generation connections, possibly resulting in increase TO investment requirements	NGET believe the proposals reflect the group consensus and that they will result in a consistent approach across the GB network.
Point of voltage control	RWE and SPT would like the Grid Code to explicitly state that the transient requirements can be achieved by a control scheme acting at the terminals	NGET believe that the Grid Code should not describe specific methods of meeting the requirements: this is a matter in which the generator is free to select any suitable arrangement
Compliance with reactive capability requirements	RWE would like the Grid Code to say that DNO restrictions will not affect generator compliance with the reactive capability requirements	NGET believe that the restrictions relate to utilisation, not capability, and that it is not appropriate to modify the Grid Code. NGET's statement that compliance will not be affected is included in working group

		minutes and in this report.
Application of excitation system requirements to modified plant	RWE point out that some modifications will not affect performance in all areas and therefore it may not be possible to meet higher performance requirements following a modification. They would like the Grid Code wording to reflect this.	NGET will ensure that any requirements specified in the Bilateral Agreement will be based on existing requirements and any enhancements achievable by the modification. The Grid Code proposals are not intended to allow unachievable requirements to be specified. The Grid Code proposals allow for values to be set within a range. They do not specify default values.
Synchronous generating unit excitation system performance requirements	RWE have queried a number of the clauses relating to the performance of excitation systems. They also would prefer not to have exceptional values specified.	The proposals reflect the wording currently used in Bilateral Agreements and to put other values in the Grid Code would not meet the objective of the changes, which is to make visible the requirements likely to be included in a Bilateral Agreement. The inclusion of exceptional values was proposed by other working group members.
Reactive output of Power Park Modules at very low/high voltages	SPT and RWE would like explicit voltage limits on where the requirements to produce maximum reactive current end	The need to give maximum reactive support when the connection point voltage is outside normal limits does not stop if the voltages get further from the normal range. The aim of the proposals is to ensure support is not removed as system conditions worsen.
Steady state response of Power Park Modules	Econnect would like CC.A.7.2.2.5 rewording such that the response must begin, but need not be completed, within 5 seconds	NGET require that the response is completed within 5 seconds to ensure consistency with its licence standards
Transient response of Power Park Modules	RWE point out that the requirement for a “linearly increasing” response does not reflect the actual performance of the likely plant operation eg. capacitor switching	NGET recognise this concern but believe that it is not possible to put suitable words in the Grid Code that would describe all of the possible acceptable solutions. NGET propose to include examples of acceptable

		solutions in the Guidance Notes
Frequency Response	SPT do not believe the proposals add any value and that further debate is needed. Econnect support this view.	NGET believe the proposals add clarification to the requirements and this view is supported by some generators

## Annex 4 – Proposed Grid Code Changes

The following extract shows the proposed changes to the Planning Code to include the additional data items.

PC.A.5.4.2.

.....  
(b) **Power Park Unit** parameters

- \* Rated MVA
- \* **Rated MW**
- \* Rated terminal voltage
- \* ~~Inertia constant (MWsec/MVA) at synchronous speed~~  
Average site air density ( $\text{kg/m}^3$ ), maximum site air density ( $\text{kg/m}^3$ ) and minimum site air density ( $\text{kg/m}^3$ ) for the year  
Year for which air density data is submitted  
Number of pole pairs  
Blade swept area ( $\text{m}^2$ )  
Gear box ratio

### Mechanical drive train

For each **Power Park Unit**, details of the parameters of the drive train represented as an equivalent two mass model should be provided. This model should accurately represent the behaviour of the complete drive train for the purposes of power system analysis studies and should include the following data items:-

- ~~Equivalent i~~nertia constant (MWsec/MVA) of the first mass (eg. wind turbine rotor and blades) at minimum, synchronous and rated speeds
- ~~Equivalent i~~nertia constant (MWsec/MVA) of the second mass (eg. generator rotor) at minimum, synchronous and rated speeds
- ~~Equivalent s~~Shaft stiffness between the two masses (Nm/electrical radian)

Additionally, for **Power Park Units** that are ~~squirrel-cage or doubly-fed~~ induction generators (eg. squirrel cage, doubly-fed) driven by wind turbines:

- \* Stator resistance
- \* Stator reactance
- \* Magnetising reactance.
- \* Rotor resistance (at starting)
- \* Rotor resistance (at rated running)
- \* Rotor reactance (at starting)
- \* Rotor reactance (at rated running)

Additionally for doubly-fed induction generators only:

The generator rotor speed range (minimum and maximum speeds in RPM)

The optimum generator rotor speed versus wind speed submitted in tabular format

Power converter rating (MVA)

.....

Transfer function block diagram, including parameters and description of the operation of the power electronic converter and fault ride through capability (where applicable).

The corresponding changes are required in the DRC Schedule 1 Data table as shown below:

DATA DESCRIPTION	UNITS	DATA CAT.	POWER PARK UNIT (OR POWER PARK MODULE, AS THE CASE MAY BE)						
			G1	G2	G3	G4	G5	G6	STN
<b>Power Park Module</b> Rated MVA	MVA	<b>SPD+</b>							
<b>Power Park Module</b> Rated MW	MW	<b>SPD+</b>							
*Performance Chart of a <b>Power Park Module</b> at the connection point		<b>SPD</b>	(see <b>OC2</b> for specification)						
* <b>Output Usable</b> (on a monthly basis)	MW	<b>SPD</b>	(except in relation to <b>CCGT Modules</b> when required on a unit basis under the <b>Grid Code</b> , this data item may be supplied under Schedule 3)						
Number & Type of <b>Power Park Units</b> within each <b>Power Park Module</b>									
<b>Power Park Unit</b> Model - A validated mathematical model in accordance with PC.5.4.2 (a)	Transfer function block diagram and algebraic equations, simulation and measured test results	<b>DPD</b>							
<b>Power Park Unit Data</b> (where applicable)									
Rated MVA	MVA	<b>SPD+</b>							
<b>Rated MW</b>	MW	<b>SPD+</b>							
Rated terminal voltage	V	<b>SPD+</b>							
<del>Inertia constant at synchronous speed</del>	<del>MW secs</del>	<del><b>SPD+</b></del>							
<a href="#">Site minimum air density</a>	$\text{kg/m}^3$	<b>SPD+</b>							
<a href="#">Site maximum air density</a>	$\text{kg/m}^3$	<b>SPD+</b>							
<a href="#">Site average air density</a>	$\text{kg/m}^3$	<b>SPD+</b>							
<a href="#">Year for which air density data is submitted</a>		<b>SPD+</b>							
<a href="#">Number of pole pairs</a>		<b>DPD</b>							
<a href="#">Blade swept area</a>	$\text{m}^2$	<b>DPD</b>							
<a href="#">Gear box ratio</a>		<b>DPD</b>							
Stator Resistance.	% on MVA	<del><b>DPD</b></del> <b>SPD+</b>							
Stator Reactance.	% on MVA	<b>SPD+</b>							
Magnetising Reactance	% on MVA	<b>SPD+</b>							
Rotor Resistance (at starting).	% on MVA	<b>DPD</b>							
Rotor Resistance (at rated running)	% on MVA	<b>SPD+</b>							
Rotor Reactance (at starting).	% on MVA	<b>DPD</b>							
Rotor Reactance (at rated running)	% on MVA	<b>SPD</b>							
<b>Equivalent inertia constant of the first mass (eg. wind turbine rotor and blades) at minimum speed</b>	MW secs /MVA	<del><b>DPD</b></del> <b>SPD+</b>							
<b>Equivalent inertia constant of the first mass (eg. wind turbine rotor and blades) at synchronous speed</b>	MW secs /MVA	<del><b>DPD</b></del> <b>SPD+</b>							
<b>Equivalent inertia constant of the first mass (eg. wind turbine rotor and blades) at rated speed</b>	MW secs /MVA	<del><b>DPD</b></del> <b>SPD+</b>							
<b>Equivalent inertia constant of the second mass (eg.</b>	MW secs	<del><b>DPD</b></del> <b>SPD+</b>							

DATA DESCRIPTION	UNITS	DATA CAT.	POWER PARK UNIT (OR POWER PARK MODULE, AS THE CASE MAY BE)						
			G1	G2	G3	G4	G5	G6	STN
generator rotor) at minimum speed Equivalent inertia constant of the second mass (eg. generator rotor) at synchronous speed Equivalent inertia constant of the second mass (eg. generator rotor) at rated speed Equivalent shaft stiffness between the two masses	/MVA MW sees /MVA MW sees /MVA Nm / electrical radian	<b>SPD+</b> <b>DPD</b> <b>SPD+</b> <b>DPD</b> <b>SPD+</b> <b>DPD</b> <b>SPD+</b>							

Schedule 1  
Page 10 of 15

DATA DESCRIPTION	UNITS	DATA CAT.	POWER PARK UNIT (OR POWER PARK MODULE, AS THE CASE MAY BE)						
			G1	G2	G3	G4	G5	G6	STN
.....  Transfer function block diagram, parameters and description of the operation of the power electronic converter including fault ride through capability (where applicable).	Diagram	<b>DPD</b>							

Glossary and Definitions

Common Collection Busbar

A busbar within a Power Park Module to which the higher voltage side of two or more Power Park Unit generator transformers are connected.

User's System Layout

PC.A.2.2.2 ....

The **Single Line Diagram** for a **Power Park Module** must include all parts of the System connecting generating equipment to the **Grid Entry Point** (or **User System Entry Point** if **Embedded**). As an alternative the **User** may choose to submit a **Single Line Diagram** with the equipment between the equivalent **Power Park Unit** and the **Common Collection Busbar** reduced to an electrically equivalent network. ~~of an electrically equivalent system connecting generating equipment to the **Grid Entry Point** (or **User System Entry Point** if **Embedded**).~~ An example of ~~The~~ **format** for a **Single Line Diagram** for a **Power Park Module** electrically equivalent system is shown in Appendix B.

PLANNING CODE APPENDIX B

Power Park Module Single Line Diagram

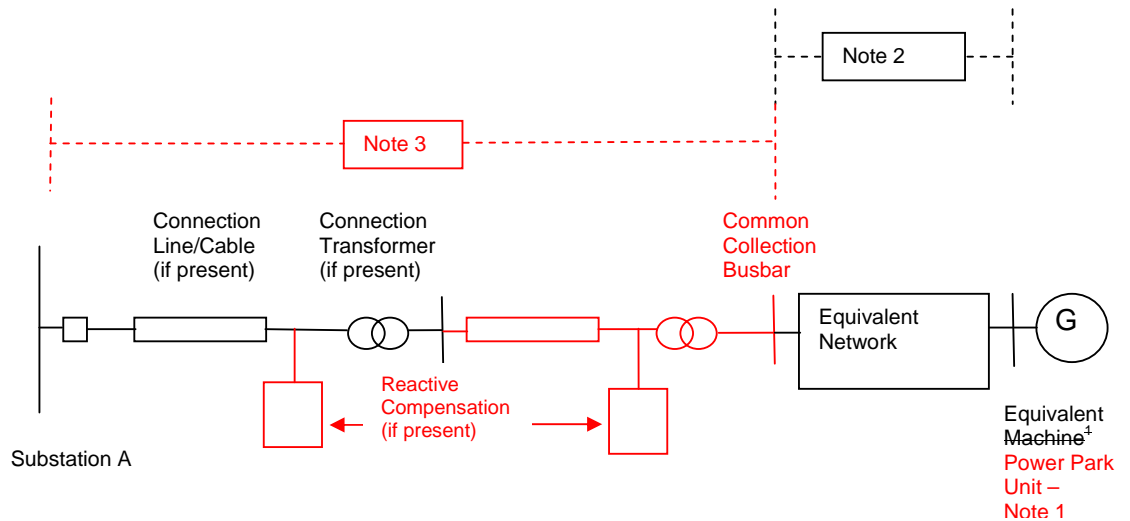

Notes:

- 1) ~~It is recommended that this~~ The electrically equivalent **Power Park Unit** consists of 'N' actual ~~generators~~ **Power Park Units** of the same type ie. any equipment external to the ~~generator~~ **Power Park Unit** terminals is considered as part of the Equivalent Network. **Power Park Units** of different types shall be included in separate electrically equivalent **Power Park Units**. The total number of equivalent **Power Park Units** shall represent all of the actual **Power Park Units** in the **Power Park Module**.
- 2) ~~Where a Power Park Module consists of different Power Park Units, the equivalent machine and network can be repeated for each different unit~~ Separate electrically equivalent networks are required for each electrically equivalent **Power Park Unit**. The electrically equivalent network shall include all equipment between the **Power Park Unit** terminals and the **Common Collection Busbar**.
- 3) All **Plant** and **Apparatus** including the circuit breakers, transformers, lines, cables and reactive compensation plant between the **Common Collection Busbar** and Substation A shall be shown.

Short Circuit Contribution to GB Transmission System

PC.A.2.5.5.2 Auxiliary motor short circuit current contribution and any **Auxiliary Gas Turbine Unit** contribution through the **Unit Transformers** must be represented as a combined short circuit current contribution at the **Generating Unit's** terminals, assuming a fault at that location. ~~In the case of a Power Park Unit in a Power Park Module, the combined short circuit contribution need only be provided for each type of Power Park Unit in the Power Park Module.~~

PC.A.2.5.5.7 For each **Power Park Module** and each type of **Power Park Unit** (eg. Doubly Fed Induction Generator), including any **Auxiliaries**, positive, negative and zero sequence root mean square current values are to be provided of the contribution to the short circuit current flowing at

- (i) the **Power Park Unit** terminals, or the **Common Collection Busbar** if an equivalent **Single Line Diagram** and associated data as described in PC.A.2.2.2 is provided, and
- (ii) the **Grid Entry Point**, or **User System Entry Point** if **Embedded**

for the following solid faults at the **Grid Entry Point**, or **User System Entry Point** if **Embedded**:-

- (i) a symmetrical three phase short circuit
- (ii) a single phase to earth short circuit
- (iii) a phase to phase short circuit
- (iv) a two phase to earth short circuit

For a **Power Park Module** in which one or more of the **Power Park Units** utilise a protective control such as a crowbar circuit, the data should indicate whether the protective control will act in each of the above cases and the effects of its action shall be included in the data. For any case in which the protective control will act, the data for the fault shall also be submitted for the limiting case in which the protective circuit will not act, which may involve the application of a non-solid fault, and the positive, negative and zero sequence retained voltages at

- (i) the **Power Park Unit** terminals, or the **Common Collection Busbar** if an equivalent **Single Line Diagram** and associated data is provided and
- (ii) the **Grid Entry Point**, or **User System Entry Point** if **Embedded**

in this limiting case shall be provided.

For each fault for which data is submitted, the data items listed under the following parts of PC.A.2.5.6(a) shall be provided:-

(iv), (vii), (viii), (ix), (x);

In addition, if an equivalent **Single Line Diagram** has been provided the data items listed under the following parts of PC.A.2.5.6(a) shall be provided:-

(xi), (xii), (xiii);

In addition, for a **Power Park Module** in which one or more of the **Power Park Units** utilise a protective control such as a crowbar circuit:-

the data items listed under the following parts of P.C.A.2.5.6(a) shall be provided:-

(xiv), (xv);

All of the above data items shall be provided in accordance with the detailed provisions of PC.A.2.5.6(c), (d), (f).

### Variation of Infeed during Faults

#### PC.A.2.5.6      Data Items

(a) The following is the list of data utilised in this part of the **PC**. It also contains rules on the data which generally apply:-

- (vii) A continuous trace and a table showing the root mean square of the positive, negative and zero sequence components of the short circuit current between zero and 140ms at 10ms intervals.
- (viii) The MWs being generated pre-fault by the **Power Park Module** and by each type of **Power Park Unit**
- (ix) The reactive compensation shown explicitly on the **Single Line Diagram** that is switched in

- (x) The **Power Factor** of the **Power Park Module** and of each **Power Park Unit** type
- (xi) The positive sequence X/R ratio of the equivalent at the **Common Collection Busbar**
- (xii) The minimum zero sequence impedance of the equivalent seen from the **Common Collection Busbar**
- (xiii) The number of **Power Park Units** represented in the equivalent **Power Park Unit**
- (xiv) The additional rotor resistance and reactance (if any) that is applied to the **Power Park Unit** under a fault condition
- (xv) A continuous trace and a table showing the root mean square of the positive, negative and zero sequence components of the retained voltage at the fault point and **Power Park Unit** terminals, or the **Common Collection Busbar** if an equivalent **Single Line Diagram** and associated data as described in **PC.A.2.2.2** is provided, representing the limiting case, which may involve the application of a non-solid fault, required to not cause operation of the protective control

The information requested by the Planning Code is submitted by Users on the schedules contained in the Data Registration Code. National Grid proposes to add a third sheet to Schedule 14 to cover the Planning Code Changes relating to fault infeed data for Power Park Units.

SCHEDULE 14

Page 3 of 3

Fault infeeds from **Power Park Modules**

A submission is required for the whole **Power Park Module** and for each **Power Park Unit** type or equivalent. The submission shall represent operating conditions that result in the maximum fault infeed. The fault current from all motors normally connected to the **Power Park Unit's electrical system** shall be included. The fault infeed shall be expressed as a fault current at the terminals of the **Power Park Unit**, or the **Common Collection Busbar** if an equivalent **Single Line Diagram** and associated data as described in PC.A.2.2.2 is provided, and the **Grid Entry Point**, or **User System Entry Point** if **Embedded**, for a fault at the **Grid Entry Point**, or **User System Entry Point** if **Embedded**.

Should actual data in respect of fault infeeds be unavailable at the time of the application for a **CUSC Contract**, a limited subset of the data, representing the maximum fault infeed that may result from all of the plant types being considered, shall be submitted. This data will, as a minimum, include the continuous time trace and table showing the root mean square of the positive, negative and zero sequence components of the fault current for both single phase and three phase solid faults at the **Grid Entry Point** (or **User System Entry Point** if **Embedded**). Actual data in respect of fault infeeds shall be submitted to **NGET** as soon as it is available, in line with PC.A.1.2.

<u>DATA DESCRIPTION</u>	<u>UNITS</u>	<u>F.Yr.</u> <u>0</u>	<u>F.Yr.</u> <u>1</u>	<u>F.Yr.</u> <u>2</u>	<u>F.Yr.</u> <u>3</u>	<u>F.Yr.</u> <u>4</u>	<u>F.Yr.</u> <u>5</u>	<u>F.Yr.</u> <u>6</u>	<u>F.Yr.</u> <u>7</u>
<u>Name of <b>Power Station</b></u>									

Name of **Power Park Module**

**Power Park Unit type**

A submission shall be provided for the contribution of the entire **Power Park Module** and each type of **Power Park Unit** or equivalent to the positive, negative and zero sequence components of the short circuit current at the **Power Park Unit** terminals, or **Common Collection Busbar**, and **Grid Entry Point** or **User System Entry Point** if **Embedded** for (i) a solid symmetrical three phase short circuit (ii) a solid single phase to earth short circuit (iii) a solid phase to phase short circuit (iv) a solid two phase to earth short circuit at the **Grid Entry Point** or **User System Entry Point** if **Embedded**.

If protective controls are used and active for the above conditions, a submission shall be provided in the limiting case where the protective control is not active. This case may require application of a non-solid fault, resulting in a retained voltage at the fault point.

- A continuous time trace and table showing the root mean square of the positive, negative and zero sequence components of the fault current from the time of fault inception to 140ms after fault inception at 10ms intervals

Graphical and tabular

kA versus s

- A continuous time trace and table showing the positive, negative and zero sequence components of retained voltage at the terminals or **Common Collection Busbar**, if appropriate

p.u. versus s

- A continuous time trace and table showing the root mean square of the positive, negative and zero sequence components of retained voltage at the fault point, if appropriate

p.u. versus s

For **Power Park Units** that utilise a protective control, such as a crowbar circuit,

- <u>additional rotor resistance applied to the <b>Power Park Unit</b> under a fault situation</u>	<u>% on MVA</u>								
- <u>additional rotor reactance applied to the <b>Power Park Unit</b> under a fault situation.</u>	<u>% on MVA</u>								
<u>Positive sequence X/R ratio of the equivalent at time of fault at the <b>Common Collection Busbar</b></u>									
<u>Minimum zero sequence impedance of the equivalent at <b>Common Collection Busbar</b></u>									
<u>MW generated pre-fault</u>	<u>MW</u>								
<u>Number of <b>Power Park Units</b> in equivalent generator</u>									
<u>Power Factor (lead or lag)</u>									
<u>Pre-fault voltage (if different from 1.0 p.u.) at fault point (See note 1)</u>	<u>p.u.</u>								
<u>Items of reactive compensation switched in pre-fault</u>									

Note 1. The pre-fault voltage provided above should represent the voltage within the range 0.95 to 1.05 that gives the highest fault current

Extension of a Power Park Module

CC.6.3 GENERAL GENERATING UNIT REQUIREMENTS

CC.6.3.1 This section sets out the technical and design criteria and performance requirements for **Generating Units, DC Converters** and **Power Park Modules** (whether directly connected to the **GB Transmission System** or **Embedded**) which each **Generator** or **DC Converter Station** owner must ensure are complied with in relation to its **Generating Units, DC Converters** and **Power Park Modules** but does not apply to **Small Power Stations** or individually to **Power Park Units**. References to **Generating Units, DC Converters** and **Power Park Modules** in this CC.6.3 should be read accordingly.

Voltage Control and Reactive Range Reactive Range below 20% Power Output

CC6.3.8 .....

(c) In the case of a **Non-synchronous Generating Unit, DC Converter** or **Power Park Module** a continuously-acting automatic control system is

required to provide control of the voltage (or zero transfer of **Reactive Power** as applicable to CC.6.3.2) at the **Grid Entry Point** or **User System Entry Point** without instability over the entire operating range of the **Non-Synchronous Generating Unit, DC Converter** or **Power Park Module**. In the case of a **Power Park Module** in Scotland, voltage control may be at the **Power Park Unit** terminals, an appropriate intermediate busbar or the **Connection Point** as specified in the **Bilateral Agreement**. **When operating below 20% Rated MW the automatic control system may continue to provide voltage control utilising any available reactive capability. If voltage control is not being provided,** the automatic control system shall be designed to ensure a smooth transition between the shaded area bound by CD and the non shaded area bound by AB in Figure 1 of CC6.3.2 (c). The performance requirements for this automatic control system will be specified in the **Bilateral Agreement**.

Notes:

this change interacts with the proposed drafting for voltage control

Harmonisation of point of voltage control and point of reactive capability requirement

The revised drafting for CC.6.3.2(c) is shown below.

CC.6.3.2 .....

- (c) Subject to the provisions of CC.6.3.2(d) below, all **Non-Synchronous Generating Units, DC Converters** (excluding current source technology) and **Power Park Modules** (excluding those connected to the **Total System** by a current source **DC Converter**) with a **Completion Date** on or after 1 January 2006 must be capable of supplying **Rated MW** output at any point between the limits 0.95 **Power Factor** lagging and 0.95 **Power Factor** leading at the **Grid Entry Point (or User System Entry Point if Embedded)**, in England and Wales or at the HV side of the 33/132kV or 33/275kV or 33/400kV transformer for ~~Generators directly connected to the GB Transmission System in Scotland (or User System Entry Point if Embedded)~~. With all **Plant** in service, the **Reactive Power** limits defined at **Rated MW** at Lagging **Power Factor** will apply at all **Active Power** output levels above 20% of the **Rated MW** output as defined in Figure 1. With all **Plant** in service, the **Reactive Power** limits defined at **Rated MW** at Leading **Power Factor** will apply at all **Active Power** output levels above 50% of the **Rated MW** output as defined in Figure 1. With all **Plant** in service, the **Reactive Power** limits will reduce linearly below 50% **Active Power** output as shown in Figure 1 unless the requirement to maintain the **Reactive Power** limits defined at **Rated MW** at Leading **Power Factor** down to 20% **Active Power** output is specified in the **Bilateral Agreement**. These **Reactive Power** limits will be reduced pro rata to the amount of **Plant** in service.

The revised drafting for the Glossary and Definitions, CC.6.3.8, BCA2.A.2.5 and BC2.A.2.6 plus an additional appendix, APPENDIX 6, is shown below.

Glossary and Definitions

<b>Automatic Voltage Regulator</b> or <b>AVR</b>	A continuously acting automatic excitation system to control a <b>Generating Unit</b> terminal voltage. <b>The continuously acting</b>
--	--

	automatic equipment controlling the terminal voltage of a <b>Synchronous Generating Unit</b> by comparing the actual terminal voltage with a reference value and controlling by appropriate means the output of an <b>Exciter</b> , depending on the deviations
<b>Setpoint Voltage</b>	The voltage at the <b>Grid Entry Point</b> , or <b>User System Entry Point if Embedded</b> , at which the transfer of <b>Reactive Power</b> between a <b>Power Park Module, DC Converter</b> or <b>Non-Synchronous Generating Unit</b> and the <b>Transmission System</b> , or <b>Network Operator's system if Embedded</b> , is zero.

CC6.3.8 .....

- (b) In respect of **Synchronous Generating Units** with a **Completion Date** before 1 January 2007, the requirements for excitation control facilities, including **Power System Stabilisers**, where in **NGET's** view these are necessary for system reasons, will be specified in the **Bilateral Agreement**. The performance requirements for a continuously acting automatic excitation control system that shall be complied with by the User in respect of **Synchronous Generating Units** with a **Completion Date** on or after 1 January 2007, or subject to a **Modification** to the continuously acting automatic excitation control system on or after 1 January 2007, are given or referred to in CC.A.6. Reference is made to on-load commissioning witnessed by **NGET** in BC2.11.2.
- (c) In the case of a **Non-synchronous Generating Unit, DC Converter** or **Power Park Module** a continuously-acting automatic control system is required to provide control of the voltage (or zero transfer of **Reactive Power** as applicable to CC.6.3.2) at the **Grid Entry Point** or **User System Entry Point** without instability over the entire operating range of the **Non-Synchronous Generating Unit, DC Converter** or **Power Park Module**. Any **Plant** or **Apparatus** used in the provision of such voltage control within a **Power Park Module** may be located at the **Power Park Unit** terminals, an appropriate intermediate busbar or the **Connection Point**. In the case of a **Power Park Module** in Scotland with a **Completion Date** before 1 January 2007, voltage control may be at the **Power Park Unit** terminals, an appropriate intermediate busbar or the **Connection Point** as specified in the **Bilateral Agreement**. When operating below 20% **Rated MW** the automatic control system may continue to provide voltage control utilising any available reactive capability. If voltage control is not being provided, the automatic control system shall be designed to ensure a smooth transition between the shaded area bound by CD and the non shaded area bound by AB in Figure 1 of CC6.3.2 (c). ~~The performance requirements for this automatic control system will be specified in the **Bilateral Agreement**.~~
- (d) The performance requirements for a continuously acting automatic voltage control system in respect of **Power Park Modules, Non-Synchronous Generating Units** and **DC Converters** with a **Completion Date** before 1 January 2007 will be specified in the **Bilateral Agreement**. The performance requirements for a continuously acting automatic voltage control system that shall be complied with by the **User** in respect of **Power Park Modules, Non-**

Synchronous Generating Units and DC Converters with a Completion Date on or after 1 January 2007, or subject to a Modification to the continuously acting automatic voltage control system on or after 1 January 2007, are given or referred to in CC.A.7.

(ed)In particular, other control facilities, including constant Reactive Power output control modes and constant Power Factor control modes (but excluding VAR limiters) are not required. However, if present in the excitation or voltage control system they will be disabled unless recorded in the Bilateral Agreement records otherwise. Operation of such control facilities will be in accordance with the provisions contained in BC2.

## APPENDIX 6

### PERFORMANCE REQUIREMENTS FOR CONTINUOUSLY ACTING AUTOMATIC EXCITATION CONTROL SYSTEMS FOR **SYNCHRONOUS GENERATING UNITS**

- CC.A.6.1 Scope
- CC.A.6.1.1 This Appendix sets out the performance requirements of continuously acting automatic excitation control systems for Synchronous Generating Units that must be complied with by the User. This Appendix does not limit any site specific requirements that may be included in a **Bilateral Agreement** where in **NGET's** reasonable opinion these facilities are necessary for system reasons.
- CC.A.6.1.2 Where the requirements may vary between **Bilateral Agreements** the likely range of variation is given in this Appendix. It may be necessary to specify values outside this range where **NGET** identifies a system need, and notwithstanding anything to the contrary **NGET** reserves the right to specify in the **Bilateral Agreement** values outside of the ranges provided in this Appendix 6. The most common variations are in the on-load excitation ceiling voltage requirements and the response time required of the **Exciter**. Actual values will be included in the **Bilateral Agreement**.
- CC.A.6.1.3 Proposals by **Generators** to make a change to the excitation control systems are required to be notified to **NGET** under the **Planning Code** (PC.A.1.2(b) and (c)) as soon as the **Generator** anticipates making the change. The change may require a revision to the **Bilateral Agreement**.
- CC.A.6.2 Requirements
- CC.A.6.2.1 The **Excitation System** of a **Synchronous Generating Unit** shall include an excitation source (**Exciter**), a **Power System Stabiliser** and a continuously acting **Automatic Voltage Regulator (AVR)** and shall meet the following functional specification.
- CC.A.6.2.2 The continuously acting automatic excitation control system shall include a **Power System Stabiliser (PSS)** as a means of supplementary control. For the avoidance of doubt this applies to replacement excitation systems fitted to existing **Generating Units** during the life-time of the **Power Station** as well as new **Generating Units**. The functional specification of the **Power System Stabiliser** is included in CC.A.6.2.5.
- CC.A.6.2.3 Steady State Voltage Control
- CC.A.6.2.3.1 An accurate steady state control of the **Generating Unit** pre-set terminal voltage is required. As a measure of the accuracy of the steady-state voltage control, the **Automatic Voltage Regulator** shall have static zero frequency gain, sufficient to limit

the change in terminal voltage to a drop not exceeding 0.5% of rated terminal voltage, when the **Generating Unit** output is gradually changed from zero to rated MVA output at rated voltage, **Active Power** and **Frequency**.

#### CC.A.6.2.4 Transient Voltage Control

CC.A.6.2.4.1 For a step change from 90% to 100% of the nominal **Generating Unit** terminal voltage, with the **Generating Unit** on open circuit, the **Excitation System** response shall have a damped oscillatory characteristic. For this characteristic, the time for the **Generating Unit** terminal voltage to first reach 100% shall be less than 0.6 seconds. Also, the time to settle within 5% of the voltage change shall be less than 3 seconds.

CC.A.6.2.4.2 To ensure that adequate synchronising power is maintained, when the **Generating Unit** is subjected to a large voltage disturbance, the **Exciter** whose output is varied by the **Automatic Voltage Regulator** shall be capable of providing its upper and lower limit ceiling voltages to the **Generating Unit** field in a time not exceeding that specified in the **Bilateral Agreement**. This will normally be not less than 50 ms and not greater than 300 ms.

CC.A.6.2.4.3 The **Exciter** shall be capable of attaining an on-load ceiling field voltage of not less than a value specified in the **Bilateral Agreement** that will be  
not less than 2 per unit (pu)  
normally not greater than 3 pu  
exceptionally up to 4 pu  
of **Rated Field Voltage** when responding to a sudden drop in voltage of 10 percent or more at the **Generating Unit** terminals. **NGET** reserves the right to specify a value outside the above limits where **NGET** identifies a system need.

CC.A.6.2.4.4 If a static type **Exciter** is employed:

- (i) the field voltage should be capable of attaining a negative ceiling level specified in the **Bilateral Agreement** that will be  
not less than 1.6 pu  
normally not greater than 2 pu  
exceptionally up to 3 pu  
of **Rated Field Voltage** after the removal of the step disturbance of CC.A.6.2.4.3. **NGET** reserves the right to specify a value outside the above limits where **NGET** identifies a system need.
- (ii) the **Exciter** must be capable of maintaining free firing when the **Generating Unit** terminal voltage is depressed to a level which may be between 20% to 30% of rated terminal voltage
- (iii) the **Exciter** shall be capable of attaining a positive ceiling voltage not less than a value specified in the **Bilateral Agreement** that will be  
not less than 1.6 pu  
normally not greater than 2 pu  
exceptionally up to 3 pu  
of **Rated Field Voltage** upon recovery of the **Generating Unit** terminal voltage to 80% of rated terminal voltage following fault clearance. **NGET** reserves the right to specify a value outside the above limits where **NGET** identifies a system need.
- (iv) The requirement to provide a separate power source for the **Exciter** will be included in the **Bilateral Agreement** if **NGET** identifies a **Transmission System** need.

#### CC.A.6.2.5 Power Oscillations Damping Control

CC.A.6.2.5.1 To allow the **Generating Unit** to maintain second and subsequent swing stability and also to ensure an adequate level of low frequency electrical damping power, the

**Automatic Voltage Regulator** shall include a **Power System Stabiliser** as a means of supplementary control.

- CC.A.6.2.5.2 Whatever supplementary control signal is employed, it shall be of the type which operates into the **Automatic Voltage Regulator** to cause the field voltage to act in a manner which results in the damping power being improved while maintaining adequate synchronising power.
- CC.A.6.2.5.3 The arrangements for the supplementary control signal shall ensure that the **Power System Stabiliser** output signal relates only to changes in the supplementary control signal and not the steady state level of the signal. For example, if generator electrical power output is chosen as a supplementary control signal then the **Power System Stabiliser** output should relate only to changes in generator electrical power output and not the steady state level of power output.
- CC.A.6.2.5.4 The output signal from the **Power System Stabiliser** shall be limited to not more than 10% of the **Generating Unit** terminal voltage signal at the **Automatic Voltage Regulator** input. The gain of the **Power System Stabiliser** shall be such that an increase in the gain by a factor of 3 shall not cause instability.
- CC.A.6.2.5.5 The **Power System Stabiliser** shall include elements which provide a limited bandwidth output signal. The bandwidth limiting must ensure that the highest frequency of response cannot excite torsional oscillations on other plant connected to the network. A bandwidth of 0-5Hz would be judged to be acceptable for this application.
- CC.A.6.2.5.6 The **Generator** will agree **Power System Stabiliser** settings with **NGET** prior to the on-load commissioning detailed in BC2.11.2(d). To allow assessment of the performance before commissioning the **Generator** will provide to **NGET** a report containing:
- i. the **Excitation System** model including the **Power System Stabiliser** with settings as required under the **Planning Code** (PC.A.5.3.2(c)).
  - ii. on load time series simulations of the response of the **Excitation System** with and without the **Power System Stabiliser** to 2% and 10% steps in the reference voltage and a three phase short circuit fault applied to the higher voltage side of the **Generating Unit** transformer for 100 ms. The results should show field voltage, **Generating Unit** terminal voltage, **Power System Stabiliser** output and **Generating Unit Active Power** and **Reactive Power** output.
  - iii. gain and phase Bode diagrams for the open loop frequency domain response of the **Generating Unit Excitation System** with and without the **Power System Stabiliser**, operating under maximum leading conditions and minimum fault level conditions as agreed with **NGET**. These should be in a format to allow assessment of the phase contribution of the **Power System Stabiliser** and the gain and phase margin of the **Excitation System** with the **Power System Stabiliser**
- CC.A.6.2.6 Overall **Excitation System** Control Characteristics
- CC.A.6.2.6.1 The overall **Excitation System** shall include elements which provide a limited bandwidth output. The bandwidth limiting must be consistent with the speed of response requirements and ensure that the highest frequency of response cannot excite torsional oscillations on other plant connected to the network. A bandwidth of 0-5 Hz will be judged to be acceptable for this application.
- CC.A.6.2.6.2 As a measure of the ability of the overall **Excitation System** to provide adequate damping, the **Automatic Voltage Regulator** shall be arranged initially to respond to step signal disturbances injected into its reference voltage level. With the

**Generating Unit** operating on no load at rated voltage and disconnected from the network, small step signal disturbances into the **Automatic Voltage Regulator** shall demonstrate that the generator terminal voltage is well damped. The step signal disturbances shall not exceed 5%. For this step change the time for the **Generating Unit** voltage to first reach 100% shall be less than 0.4 seconds and the settling time to within  $\pm 5\%$  of the voltage change shall be less than 1.6 seconds.

CC.A.6.2.6.3 The response of the **Automatic Voltage Regulator** combined with the **Power System Stabiliser** shall be demonstrated by injecting similar step signal disturbances into the **Automatic Voltage Regulator** reference with the **Generating Unit** operating at points specified by NGET (up to rated MVA output). The damping shall be judged to be adequate if the corresponding **Active Power** response to the disturbances decays within two cycles of oscillation.

CC.A.6.2.6.4 The frequency domain tuning of the **Power System Stabiliser** shall also be demonstrated by injecting a 200mHz-3Hz band limited random noise signal into the **Automatic Voltage Regulator** reference with the **Generating Unit** operating at points specified by NGET (up to rated MVA output). The tuning of the **Power System Stabiliser** shall be judged to be adequate if the corresponding **Active Power** response shows improved damping with the **Power System Stabiliser** in combination with the **Automatic Voltage Regulator** compared with the **Automatic Voltage Regulator** alone over the frequency range 0.3Hz – 2Hz.

#### CC.A.6.2.7 **Under-Excitation Limiter** Units

CC.A.6.2.7.1 The security of the power system shall also be safeguarded by means of Mvar **Under Excitation Limiters** fitted to the generator **Excitation System**. The **Under Excitation Limiter** shall prevent the **Automatic Voltage Regulator** reducing the generator excitation to a level which would endanger synchronous stability. The **Under Excitation Limiter** shall operate during automatic control. The **Under Excitation Limiter** shall respond to changes in the **Active Power** (MW) and the **Reactive Power** (MVA<sub>r</sub>), and to the square of the generator voltage in such a direction that an increase in voltage will permit an increase in leading MVA<sub>r</sub>. The characteristic of the **Under Excitation Limiter** shall be substantially linear from no-load to rated load at any setting and shall be readily adjustable.

CC.A.6.2.7.2 The performance of the **Under Excitation Limiter** shall be independent of the rate of change of the **Generating Unit** load and shall be demonstrated by testing its response to a step change corresponding to a 2% decrease in **Automatic Voltage Regulator** reference voltage when the generator is operating just off the limit line, as set up. The resulting maximum overshoot shall not exceed 4% of the **Generating Unit** rated MVA. The operating point of the **Generating Unit** shall be returned to a steady state value at the limit line and the final settling time shall not be greater than 5 seconds. When the step change in **Automatic Voltage Regulator** reference voltage is reversed, the field voltage should begin to respond without any delay and should not be held down by the **Under Excitation Limiter**. Operation into or out of the preset limit levels shall ensure that any resultant oscillations are damped so that the disturbance is within 0.5% of the **Generating Unit** MVA rating within a period of 5 seconds.

CC.A.6.2.7.3 The **Generator** shall also make provision to prevent the reduction of the **Generating Unit** excitation to a level which would endanger synchronous stability when the **Excitation System** is under manual control.

#### CC.A.6.2.8 **Over-Excitation Limiter** Units

- CC.A.6.2.8.1 The settings of the **Over-Excitation Limiter** shall ensure that the generator excitation is not limited to less than the maximum value that can be achieved whilst ensuring the **Generating Unit** is operating within its design limits. If the generator excitation is reduced following a period of operation at a high level, the rate of reduction shall not exceed that required to remain within any time dependent operating characteristics of the **Generating Unit**.
- CC.A.6.2.8.2 The performance of the **Over-Excitation Limiter** shall be demonstrated by testing its response to a step change corresponding to a 2% increase in the **Automatic Voltage Regulator** reference voltage when the **Generating Unit** is operating just off the **Over-Excitation Limit**. The resulting operation beyond the **Over-Excitation Limit** shall be controlled by the **Over-Excitation Limiter** without the operation of any protection that could trip the **Generating Unit**.
- CC.A.6.2.8.3 The **Generator** shall also make provision to prevent any restriction of the generator excitation when the **Excitation System** is under manual control, other than that necessary to ensure the **Generating Unit** is operating within its design limits.

## APPENDIX 7

### PERFORMANCE REQUIREMENTS FOR CONTINUOUSLY ACTING AUTOMATIC VOLTAGE CONTROL SYSTEMS FOR **NON-SYNCHRONOUS GENERATING UNITS, DC CONVERTERS AND POWER PARK MODULES**

#### CC.A.7.1 SCOPE

CC.A.7.1.1 This Appendix sets out the performance requirements of continuously acting automatic voltage control systems for **Non-Synchronous Generating Units, DC Converters and Power Park Modules** that must be complied with by the User. This Appendix does not limit any site specific requirements that may be included in a **Bilateral Agreement** where in **NGET's** reasonable opinion these facilities are necessary for system reasons.

CC.A.7.1.2 Proposals by **Generators** to make a change to the voltage control systems are required to be notified to **NGET** under the **Planning Code** (PC.A.1.2(b) and (c)) as soon as the **Generator** anticipates making the change. The change may require a revision to the **Bilateral Agreement**.

#### CC.A.7.2 Requirements

CC.A.7.2.1 **NGET** requires that the continuously acting automatic voltage control system for the **Non-Synchronous Generating Unit, DC Converter or Power Park Module** shall meet the following functional performance specification. If a **Network Operator** has confirmed to **NGET** that its network to which an **Embedded Non-Synchronous Generating Unit, DC Converter or Power Park Module** is connected is restricted such that the full reactive range under the steady state voltage control requirements (**CC.A.7.2.2**) cannot be utilised, **NGET** may specify alternative limits to the steady state voltage control range reflecting the restrictions in the **Bilateral Agreement**. Where the **Network Operator** subsequently notifies **NGET** that such restriction has been removed, **NGET** may propose a **Modification** to the **Bilateral Agreement** (in accordance with the **CUSC** contract) to remove the alternative limits such that the continuously acting automatic voltage control system meets the following functional performance specification. All other requirements of the voltage control system will remain as in this Appendix.



**Grid Entry Point voltage  
(or User System Entry Point voltage if Embedded)**

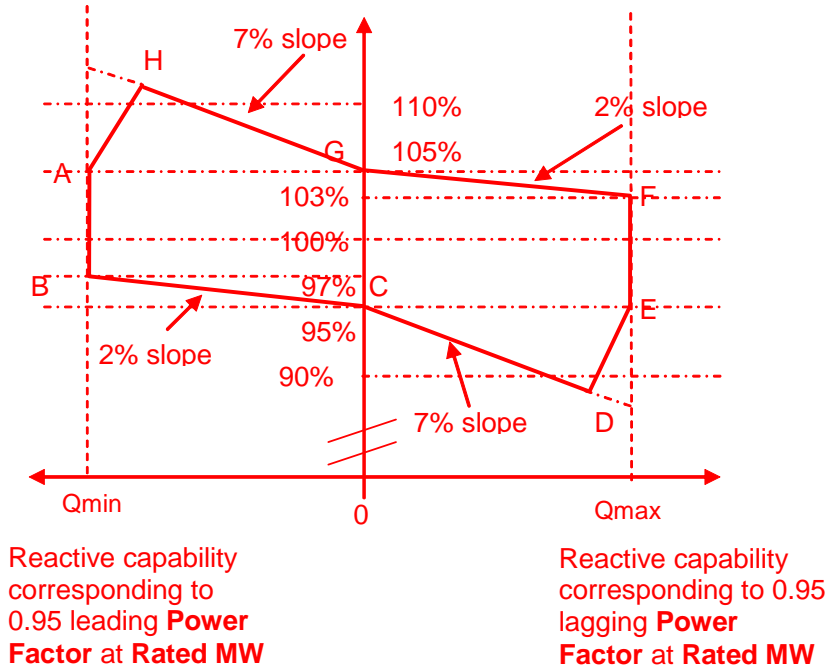

Figure CC.A.7.2.2b

- CC.A.7.2.2.4 Figure CC.A.7.2.2b shows the required envelope of operation. The enclosed area within points ABCDEFGH is the required capability range of the **Non-Synchronous Generating Unit, DC Converter or Power Park Module** within which the **Slope** and **Setpoint Voltage** can be changed.
  
- CC.A.7.2.2.5 Should the operating point of the **Non-Synchronous Generating Unit, DC Converter or Power Park Module** deviate so that it is no longer a point on the operating characteristic (figure CC.A.7.2.2a) defined by the target **Setpoint Voltage** and **Slope**, the continuously acting automatic voltage control system shall act progressively to return the value to a point on the required characteristic within 5 seconds.
  
- CC.A.7.2.2.6 Should the **Reactive Power** output of the **Non-Synchronous Generating Unit, DC Converter or Power Park Module** reach its maximum lagging limit at a **Grid Entry Point voltage (or User System Entry Point voltage if Embedded)** above 95%, the **Non-Synchronous Generating Unit, DC Converter or Power Park Module** shall maintain maximum lagging **Reactive Power** output for voltage reductions down to 95%. This requirement is indicated by the line EF in figure CC.A.7.2.2b. Should the **Reactive Power** output of the **Non-Synchronous Generating Unit, DC Converter or Power Park Module** reach its maximum leading limit at a **Grid Entry Point voltage (or User System Entry Point voltage if Embedded)** below 105%, the **Non-Synchronous Generating Unit, DC Converter or Power Park Module** shall maintain maximum leading **Reactive Power** output for voltage increases up to 105%. This requirement is indicated by the line AB in figure CC.A.7.2.2b.
  
- CC.A.7.2.2.7 For **Grid Entry Point voltages (or User System Entry Point voltages if Embedded)** below 95%, the lagging **Reactive Power** capability of the **Non-Synchronous Generating Unit, DC Converter or Power Park Module** should be that which results

from the supply of maximum lagging reactive current whilst ensuring the current remains within design operating limits. An example of the capability is shown by the line DE in figure CC.A.7.2.2b. For **Grid Entry Point** voltages (or **User System Entry Point** voltages if **Embedded**) above 105%, the leading **Reactive Power** capability of the **Non-Synchronous Generating Unit, DC Converter or Power Park Module** should be that which results from the supply of maximum leading reactive current whilst ensuring the current remains within design operating limits. An example of the capability is shown by the line AH in figure CC.A.7.2.2b. Should the **Reactive Power** output of the **Non-Synchronous Generating Unit, DC Converter or Power Park Module** reach its maximum lagging limit at a **Grid Entry Point** voltage (or **User System Entry Point** voltage if **Embedded**) below 95%, the **Non-Synchronous Generating Unit, DC Converter or Power Park Module** shall maintain maximum lagging reactive current output for further voltage decreases. Should the **Reactive Power** output of the **Non-Synchronous Generating Unit, DC Converter or Power Park Module** reach its maximum leading limit at a **Grid Entry Point** voltage (or **User System Entry Point** voltage if **Embedded**) above 105%, the **Non-Synchronous Generating Unit, DC Converter or Power Park Module** shall maintain maximum leading **Reactive Power** output for further voltage increases.

#### CC.A.7.2.3 Transient Voltage Control

CC.A.7.2.3.1 For a step change in **Grid Entry Point** or **User System Entry Point** voltage, the continuously acting automatic control system shall respond according to the following minimum criteria

- i. the **Reactive Power** output of the **Non-Synchronous Generating Unit, DC Converter or Power Park Module** shall change linearly with time. The response should commence within 0.2 seconds of the application of the step.
- ii. the response rate shall be such that, for a sufficiently large step, 90% of the full reactive capability of the **Non-Synchronous Generating Unit, DC Converter or Power Park Module**, as required by CC.6.3.2, will be produced within 1 second
- iii. the magnitude of the change in the **Reactive Power** produced within 1 second shall vary linearly in proportion to the magnitude of the step change
- iv. the settling time shall be no greater than 2 seconds from the application of the step change in voltage and the peak to peak magnitude of any oscillations shall be less than 5% of the change in steady state **Reactive Power** within this time.
- v. following the transient response, the conditions of CC.7.2.2.5 apply

This on load requirement shall apply irrespective of the magnitude of the step change or disturbance.

#### CC.A.7.2.4 Power Oscillation Damping

CC.A.7.2.4.1 The requirement for the continuously acting voltage control system to be fitted with a **Power System Stabiliser (PSS)** shall be specified in the **Bilateral Agreement** if, in **NGET's** view, this is required for system reasons. However if a **Power System Stabiliser** is included in the voltage control system its settings and performance shall be agreed with **NGET** and commissioned in accordance with **BC.2.11.2**.

#### CC.A.7.2.5 Overall Voltage Control System Characteristics

CC.A.7.2.5.1 The continuously acting automatic voltage control system is required to respond to minor variations, steps, gradual changes or major variations in **Grid Entry Point** voltage (or **User System Entry Point** voltage if **Embedded**).

CC.A.7.2.5.2 The overall voltage control system shall include elements which provide a limited bandwidth output. The bandwidth limiting must be consistent with the speed of response requirements and ensure that the highest frequency of response cannot excite torsional oscillations on other plant connected to the network. A bandwidth of 0-5Hz would be judged to be acceptable for this application. All other control systems employed within the Non-Synchronous Generating Unit, DC Converter or Power Park Module should also meet this requirement

CC.A.7.2.5.3 The response of the voltage control system (including the **Power System Stabiliser** if employed) shall be demonstrated by applying suitable step disturbances into the voltage control system of the **Power Park Module** or **Power Park Unit**, or by changing the actual voltage at a suitable point, with the generator operating at points specified by **NGET** (up to rated MVA output). The damping shall be judged to be adequate if the corresponding **Active Power** response to the disturbances decays within 2 seconds of the application of the step.

BC2.A.2.5 ....

(b) **Ancillary Service** instructions for **Reactive Power** will normally follow the form:

- (i) an exchange of operator names;
- (ii) **BM Unit** Name;
- (iii) Time of instruction;
- (iv) Type of instruction (MVAR, VOLT, **SETPOINT**, **SLOPE** or TAPP)
- (v) Target Value
- (vi) Target Time.

The times required in the instruction are expressed as London time.

For example, for **BM Unit** ABCD-1 instructed at 1400 hours to provide 100Mvar by 1415 hours:

“**BM Unit** ABCD-1 message timed at 1400 hours. MVAR instruction. Unit to plus 100 Mvar target time 1415 hours.”

BC2.A.2.6 **Reactive Power**

As described in BC2.A.2.4 and BC2.A.2.5 instructions for **Ancillary Services** relating to **Reactive Power** may consist of any of several specific types of instruction. The following table describes these instructions in more detail:

Instruction Name	Description	Type of Instruction
<u>Mvar Output</u>	<p>The individual Mvar output from the <b>Genset</b> onto the <b>GB Transmission System</b> at the <b>Grid Entry Point</b> (or onto the <b>User System</b> at the <b>User System Entry Point</b> in the case of <b>Embedded Power Stations</b>), namely on the higher voltage side of the generator step-up transformer. In relation to each <b>Genset</b>, where there is no HV indication, <b>NGET</b> and the <b>Generator</b> will discuss and agree equivalent Mvar levels for the corresponding LV indication.</p> <p>Where a <b>Genset</b> is instructed to a specific Mvar output, the <b>Generator</b> must achieve that output within a tolerance of +/-25 Mvar (for <b>Gensets</b> in England and Wales) or the lesser of +/- 5% of rated output or 25Mvar (for <b>Gensets</b> in Scotland) (or such other figure as may be agreed with <b>NGET</b>) by tap changing on the generator step-up transformer, unless agreed otherwise. Once this has been achieved, the <b>Generator</b> will not tap again without prior consultation with and the agreement of <b>NGET</b>, on the basis that Mvar output will be allowed to vary with <b>System</b> conditions.</p>	MVAR
<u>Target Voltage Levels</u>	<p>Target voltage levels to be achieved by the <b>Genset</b> on the <b>GB Transmission System</b> at the <b>Grid Entry Point</b> (or on the <b>User System</b> at the <b>User System Entry Point</b> in the case of <b>Embedded Power Stations</b>, namely on the higher voltage side of the generator step-up transformer. Where a <b>Genset</b> is instructed to a specific target voltage, the <b>Generator</b> must achieve that target within a tolerance of <math>\pm 1</math> kV (or such other figure as may be agreed with <b>NGET</b>) by tap changing on the generator step-up transformer, unless agreed otherwise with <b>NGET</b>. In relation to each <b>Genset</b>, where there is no HV indication, <b>NGET</b> and the <b>Generator</b> will discuss and agree equivalent voltage levels for the corresponding LV indication.</p> <p>Under normal operating conditions, once this target voltage level has been achieved the <b>Generator</b> will not tap again without prior consultation with, and with the agreement of, <b>NGET</b>.</p> <p>However, under certain circumstances the <b>Generator</b> may be instructed to maintain a target voltage until otherwise instructed and this will be achieved by tap changing on the generator step-up transformer without reference to <b>NGET</b>.</p>	VOLT

Instruction Name	Description	Type of Instruction
<u>Instruction Name</u>	Description	Type of instruction
<u>Setpoint Voltage</u>	<p>Where a <b>Non-Synchronous Generating Unit, DC Converter or Power Park Module</b> is instructed to a specific <b>Setpoint Voltage</b>, the <b>Generator</b> must achieve that target within a tolerance of <math>\pm 0.25\%</math> (or such other figure as may be agreed with <b>NGET</b>).</p> <p>The <b>Generator</b> must maintain the specified <b>Setpoint Voltage</b> target until an alternative target is received from <b>NGET</b>.</p> <p>Deviations of the actual <b>Setpoint Voltage</b> from the target must be corrected within the times specified in the <b>Bilateral Agreement</b>.</p>	SETPOINT
<u>Instruction Name</u>	Description	Type of instruction
<u>Slope</u>	<p>Where a <b>Non-Synchronous Generating Unit, DC Converter or Power Park Module</b> is instructed to a specific <b>Slope</b>, the <b>Generator</b> must achieve that target within a tolerance of <math>\pm 0.5\%</math> (or such other figure as may be agreed with <b>NGET</b>).</p> <p>The <b>Generator</b> must maintain the specified <b>Setpoint Voltage</b> target until an alternative target is received from <b>NGET</b>.</p>	SLOPE

#### Power Recovery

- CC.6.3.15(a) ii) Each **Generating Unit** or **Power Park Module** shall be designed such that upon both clearance of the fault on the **GB Transmission System** as detailed in CC.6.3.15 (a) (i) and within 0.5 seconds of the restoration of the **voltage at the Grid Entry Point** to the minimum levels specified in CC.6.1.4 (or within 0.5 seconds of restoration of the voltage at the **User System Entry Point** to 90% of nominal or greater if **Embedded**), **Active Power** output shall be restored to at least 90% of the level available immediately before the fault. **Once the Active Power** output has been restored to 90% of the pre-fault level, **Active Power** oscillations shall be acceptable provided that the total **Active Energy** delivered during the period of the oscillations is at least that which would have been delivered if the **Active Power** was constant at 90% of the pre-fault level and that the oscillations are adequately damped. During the period of the fault as detailed in CC.6.3.15 (a) (i) each **Generating Unit** or **Power Park Module** shall generate maximum reactive current without exceeding the transient rating limit of the **Generating Unit** or **Power Park Module** and / or any constituent **Power Park Unit**.

- CC.6.3.15(b) (iii) restore **Active Power** output, following **Supergrid Voltage** dips as described in Figure 5, within 1 second of restoration of the voltage at

the **Grid Entry Point** to the minimum levels specified in CC.6.1.4 (or within 1 second of restoration of the voltage at the **User System Entry Point** to 90% of nominal or greater if **Embedded**), to at least 90% of the level available immediately before the occurrence of the dip except in the case of a **Non-Synchronous Generating Unit** or **Power Park Module** where there has been a reduction in the **Intermittent Power Source** in the time range in Figure 5 that restricts the **Active Power** output below this level. **Once the Active Power output has been restored to 90% of the pre-dip level (or less in the case of a Non-Synchronous Generating Unit or Power Park Module where there has been a reduction in the Intermittent Power Source in the time range in Figure 5 that restricts the Active Power output below this level), Active Power oscillations shall be acceptable provided that the total Active Energy delivered during the period of the oscillations is at least that which would have been delivered if the Active Power was constant at 90% of the pre-dip level and that the oscillations are adequately damped.**

### Unbalanced faults

This requirement should not be placed on the older wind farms completed before the H/04 requirements were implemented. Therefore clause CC.6.3.15(c) should be modified.

- (ii) In addition to meeting the conditions specified in CC.6.1.5(b) and CC.6.1.6, each **Non-Synchronous Generating Unit** or **Power Park Module** with a Completion Date after 1 April 2005 and any constituent **Power Park Unit** thereof will be required to withstand, without tripping, the negative phase sequence loading incurred by clearance of a close-up phase-to-phase fault, by **System Back-Up Protection** on the **GB Transmission System** operating at **Supergrid Voltage**.

### Power Available Signal

### Glossary and Definitions

#### Power Available

The potential available **Active Power** from a **Power Park Module** that can be delivered at the **Grid Entry Point** (or **User System Entry Point** for an **Embedded Power Park Module**) taking into consideration the number of **Power Park Units** in operation and the prevailing average energy source (eg wind speed) at the site over the sampling period.

CC.6.5.6 .....

- (d) In the case of a **Power Park Module** an additional energy input signals (e.g. wind speed and Power Available) may be specified in the **Bilateral Agreement**. The signals may be used by **NGET** to establish the level of energy input from the **Intermittent Power Source** for monitoring pursuant to CC.6.6.1 ~~and Ancillary Services~~ and will, in the case of a wind farm, be used to provide **NGET** with **both the available frequency response based on current wind speed and** advanced warning of excess wind speed shutdown.

- (e) For the **Power Available** and wind speed signals, the sampling period for each signal is required to be a maximum of 1 minute unless otherwise specified in the **Bilateral Agreement**.

#### Manned Control Rooms

- CC.7.9 **Generators** and **DC Converter Station** owners shall provide a **Control Point** in respect of each **Power Station** directly connected to the **GB Transmission System** and **Embedded Large Power Station** or **DC Converter Station**. The **Control Point** shall be continuously manned (except for **Embedded Power Stations** containing **Power Park Modules** in the ~~the SHETL Transmission Area~~ which have a ~~Registered Capacity~~ less than 30MW where the **Bilateral Agreement** in respect of such **Embedded Power Station** specifies that compliance with **BC2** is not required, where the **Control Point** shall be manned between the hours of 0800 and 1800 each day) to receive and act upon instructions pursuant to OC7 and BC2 at all times that **Generating Units** or **Power Park Modules** at the **Power Station** are generating or available to generate or **DC Converters** at the **DC Converter Station** are importing or exporting or available to do so.

#### Reactive Power output with voltage variation

- CC.6.3.4 At the **Grid Entry Point** the **Active Power** output under steady state conditions of any **Generating Unit**, **DC Converter** or **Power Park Module** directly connected to the **GB Transmission System** should not be affected by voltage changes in the normal operating range specified in CC.6.1.4 by more than the change in **Active Power** losses at reduced or increased voltage. The **Reactive Power** output under steady state conditions should be fully available within the voltage range  $\pm 5\%$  at 400kV, 275kV and 132kV and lower voltages, except for a **Power Park Module** or **Non-synchronous Generating Unit** if **Embedded** at 33kV and below (or directly connected to the **GB Transmission System** in ~~England and Wales~~ at 33kV and below) where the requirement shown in Figure 4 applies.

#### Cross referencing for LEEMPS provisions

PC.3.3 .....

PC.A.2.1.1  
PC.A.2.2.2  
PC.A.2.5.5.2  
PC.A.2.5.5.7  
PC.A.2.5.6  
PC.A.3.1.5  
PC.A.3.2.2  
PC.A.3.3.1  
PC.A.3.4.1  
PC.A.3.4.2  
PC.A.5.2.2  
PC.A.5.3.2

PC.A.5.4  
PC.A.5.5.1  
PC.A.5.6

CC.3.4 .....

CC.5.1  
CC.5.2.2  
CC.5.3  
CC.6.1.3  
CC.6.1.5 (b)  
CC.6.3.2, CC.6.3.3, CC.6.3.4, CC.6.3.6, CC.6.3.7, CC.6.3.8, CC.6.3.9,  
CC.6.3.10, CC.6.3.12, CC.6.3.13, CC.6.3.15, CC.6.3.16  
CC.6.4.4  
CC.6.5.6 (where required by CC.6.4.4)

## **Definition of Power Park Module**

### Glossary and Definitions

#### **Power Park Module**

A collection of ~~Non-synchronous~~ **Generating Units** (registered as a **Power Park Module** under the **PC**) that are powered by an **Intermittent Power Source**, joined together by a **System** with a single electrical point of connection to the **GB Transmission System** (or **User system** if **Embedded**). The connection to the **GB Transmission System** (or **User System** if **Embedded**) may include a **DC Converter**.

### **Frequency response**

#### **High Frequency Response**

An automatic reduction in **Active Power** output in response to an increase in **System Frequency** above the **Target Frequency** (or such other level of **Frequency** as may have been agreed in an **Ancillary Services Agreement**). This reduction in **Active Power** output must be in accordance with the provisions of the relevant **Ancillary Services Agreement** which will provide that it will be released increasingly with time over the period 0 to 10 seconds from the time of the **Frequency** increase on the basis set out in the **Ancillary Services Agreement** and fully achieved within 10 seconds of the time of the start of the **Frequency** increase and it must be sustained at no lesser reduction thereafter. The interpretation of the **High Frequency Response** to a + 0.5 Hz frequency change is shown diagrammatically in Figure CC.A.3.3.

#### **Primary Response**

The automatic increase in **Active Power** output of a **Genset** or, as the case may be, the decrease in **Active Power Demand** in response to a **System Frequency** fall. This increase in **Active Power** output or, as the case may be, the decrease in **Active Power Demand** must be in accordance with the provisions of the relevant **Ancillary Services Agreement** which will provide that it will be released increasingly with time over the period 0 to 10 seconds from the time of the start of the **Frequency** fall on the basis set out in the **Ancillary**

**Services Agreement** and fully available by the latter, and sustainable for at least a further 20 seconds. The interpretation of the **Primary Response** to a – 0.5 Hz frequency change is shown diagrammatically in Figure CC.A.3.2.

### Connection Conditions

CC.6.3.7 (a) Each **Generating Unit, DC Converter** or **Power Park Module** (excluding **Power Park Modules** in Scotland with a Completion Date before 1 July 2004 or in a **Power Station** in Scotland with a **Registered Capacity** less than 30MW) must be fitted with a fast acting proportional Frequency control device (or turbine speed governor) and unit load controller or equivalent control device to provide Frequency response under normal operational conditions in accordance with Balancing Code 3 (BC3). In the case of a **Power Park Module** the frequency or speed control devices may be on the **Power Park Module** or on each individual **Power Park Unit** or be a combination of both. The Frequency control device (or speed governor) must be designed and operated to the appropriate:

- (i) European Specification; or
- (ii) in the absence of a relevant European Specification, such other standard which is in common use within the European Community (which may include a manufacturer specification);

.....

(c) The Frequency control device (or speed governor) must meet the following minimum requirements:

- (i) Where a **Generating Unit, DC Converter** or **Power Park Module** becomes isolated from the rest of the **Total System** but is still supplying Customers, the Frequency control device (or speed governor) must also be able to control System Frequency below 52Hz unless this causes the **Generating Unit, DC Converter** or **Power Park Module** to operate below its **Designed Minimum Operating Level** when it is possible that it may, as detailed in BC 3.7.3, trip after a time. For the avoidance of doubt the **Generating Unit, DC Converter** or **Power Park Module** is only required to operate within the System Frequency range 47 - 52 Hz as defined in CC.6.1.3.;
- (ii) the Frequency control device (or speed governor) must be capable of being set so that it operates with an overall speed **Droop** of between 3% and 5%. For the avoidance of doubt, in the case of a **Power Park Module** the speed **Droop** should be equivalent of a fixed setting between 3% and 5% applied to each **Power Park Unit** in service;
- (iii) in the case of all **Generating Units, DC Converter** or **Power Park Module** other than the **Steam Unit** within a **CCGT Module** the Frequency control device (or speed governor) deadband should be no greater than 0.03Hz (for the avoidance of doubt,  $\pm 0.015\text{Hz}$ ). In the case of the **Steam Unit** within a **CCGT Module**, the speed governor deadband should be set to an appropriate value consistent with the

requirements of CC.6.3.7(c)(i) and the requirements of BC3.7.2 for the provision of Limited High Frequency Response;

For the avoidance of doubt, the minimum requirements in (ii) and (iii) for the provision of System Ancillary Services do not restrict the negotiation of Commercial Ancillary Services between NGET and the User using other parameters; and

.....

### APPENDIX 3

## MINIMUM FREQUENCY RESPONSE REQUIREMENT PROFILE AND OPERATING RANGE for new Power Stations and DC Converter Stations.

.....

### CC.A.3.4 TESTING OF FREQUENCY RESPONSE CAPABILITY

The response capabilities shown diagrammatically in Figure CC.A.3.1 are measured by taking the responses as obtained from some of the dynamic response tests specified by NGET and carried out by **Generators** and **DC Converter Station** owners for compliance purposes and to validate the content of **Ancillary Services Agreements** using an injection of a **Frequency** change to the plant control system (i.e. governor and load controller). The injected signal is a linear ramp from zero to 0.5 Hz **Frequency** change over a ten second period, and is sustained at 0.5 Hz **Frequency** change thereafter, as illustrated diagrammatically in figures CC.A.3.2 and CC.A.3.3. In the case of an **Embedded Medium Power Station** not subject to a **Bilateral Agreement** or **Embedded DC Converter Station** not subject to a **Bilateral Agreement**, NGET may require the **Network Operator** within whose **System** the **Embedded Medium Power Station** or **Embedded DC Converter Station** is situated, to ensure that the **Embedded Person** performs the dynamic response tests reasonably required by NGET in order to demonstrate compliance within the relevant requirements in the **CCs**.

The **Primary Response** capability (P) of a **Generating Unit** or a **CCGT Module** or **Power Park Module** or **DC Converter** is the minimum increase in **Active Power** output between 10 and 30 seconds after the start of the ramp injection as illustrated diagrammatically in Figure CC.A.3.2. This increase in Active Power output should be released increasingly with time over the period 0 to 10 seconds from the time of the start of the Frequency fall as illustrated by the response in Figure CC.A.3.2.

The **Secondary Response** capability (S) of a **Generating Unit** or a **CCGT Module** or **Power Park Module** or **DC Converter** is the minimum increase in **Active Power** output between 30 seconds and 30 minutes after the start of the ramp injection as illustrated diagrammatically in Figure CC.A.3.2.

The **High Frequency Response** capability (H) of a **Generating Unit** or a **CCGT Module** or **Power Park Module** or **DC Converter** is the decrease in **Active Power** output provided 10 seconds after the start of the ramp injection and

sustained thereafter as illustrated diagrammatically in Figure CC.A.3.3. This reduction in **Active Power** output should be released increasingly with time over the period 0 to 10 seconds from the time of the start of the **Frequency** rise as illustrated by the response in Figure CC.A.3.2.

.....

Figure CC.A.3.2 - Interpretation of Primary and Secondary Response Values

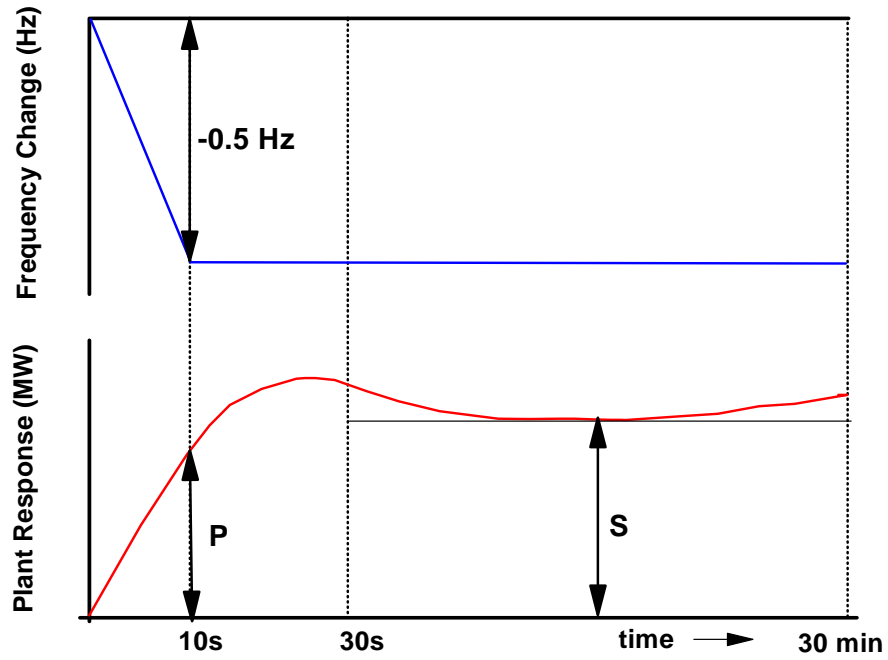
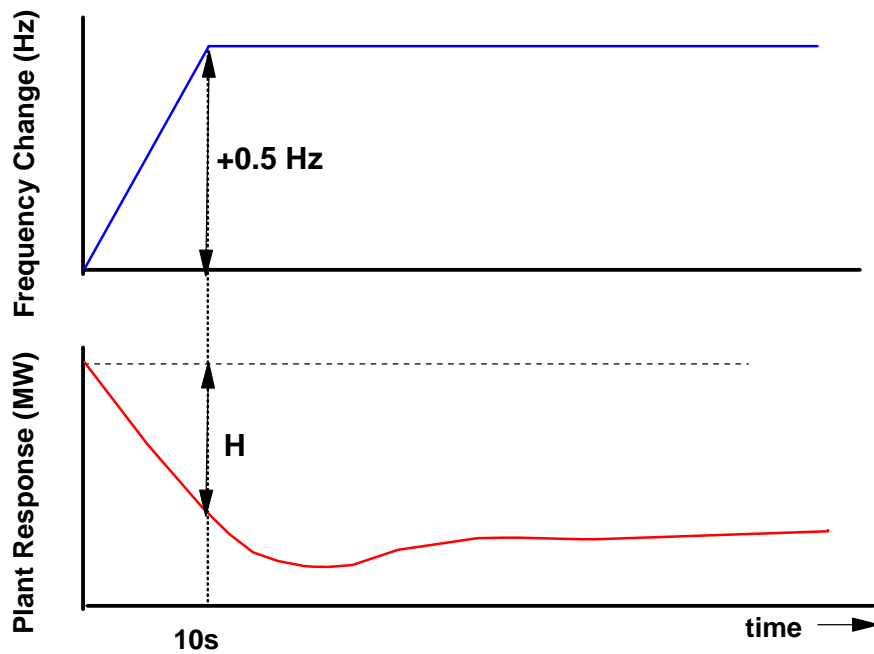

Figure CC.A.3.3 - Interpretation of High Frequency Response Values



**Schedule 5 data**

**USERS SYSTEM DATA**

DATA DESCRIPTION	UNITS	DATA CATEGORY
<b><u>PROTECTION SYSTEMS</u></b>		
<p>The following information relates only to <b>Protection</b> equipment which can trip or inter-trip or close any <b>Connection Point</b> circuit breaker or any <b>GB Transmission System</b> circuit breaker. The information need only be supplied once, in accordance with the timing requirements set out in PC.A.1.4 (b) and need not be supplied on a routine annual thereafter, although <b>NGET</b> should be notified if any of the information changes.</p>		
(a) A full description, including estimated settings, for all relays and Protection systems installed or to be installed on the <b>User's System</b> ;		<b>DPD</b>
(b) A full description of any auto-reclose facilities installed or to be installed on the <b>User's System</b> , including type and time delays;		<b>DPD</b>
(c) A full description, including estimated settings, for all relays and <b>Protection</b> systems installed or to be installed on the <b>Power Park Module</b> or <b>Generating Unit's</b> generator transformer, unit transformer, station transformer and their associated connections;		<b>DPD</b>
(d) For <b>Generating Units</b> (other than <b>Power Park Units</b> ) having a circuit breaker at the generator terminal voltage clearance times for electrical faults within the <b>Generating Unit</b> zone must be declared.		<b>DPD</b>
(e) Fault Clearance Times: Most probable fault clearance time for electrical faults on any part of the <b>Users System</b> directly connected to the <b>GB Transmission System</b> .	mSec	<b>DPD</b>

DATA DESCRIPTION	UNITS	DATA CATEGORY
<b>POWER PARK MODULE/UNIT PROTECTION SYSTEMS</b> Details of settings for the <b>Power Park Module/Unit</b> protection relays (to include): (a) Under frequency, (b) Over Frequency, (c) Under Voltage, Over Voltage, (d) Rotor Over current (e) Stator Over current,. (f) High Wind Speed Shut Down Level (g) Rotor Underspeed (h) Rotor Overspeed		DPD DPD DPD DPD DPD DPD DPD
		DPD