

Embedded Benefit

CISG

20 November 2007

nationalgrid

Embedded Benefit

TADG – Ofgem's provisional views

- ◆ Ofgem think there is a case for change
 - ◆ Cost-reflectivity
 - ◆ Allocation of transmission access
 - ◆ Commercial proportionality
- ◆ Cost-reflectivity
 - ◆ NGET should review drivers of costs associated with residual TNUoS charge, taking into account the impact of DG on such costs
 - ◆ DG should pay less (avoids some network costs) but value requires review
 - ◆ Review should address treatment of generation under 100MW connected at 132kV across GB

Embedded Benefit

What is it?

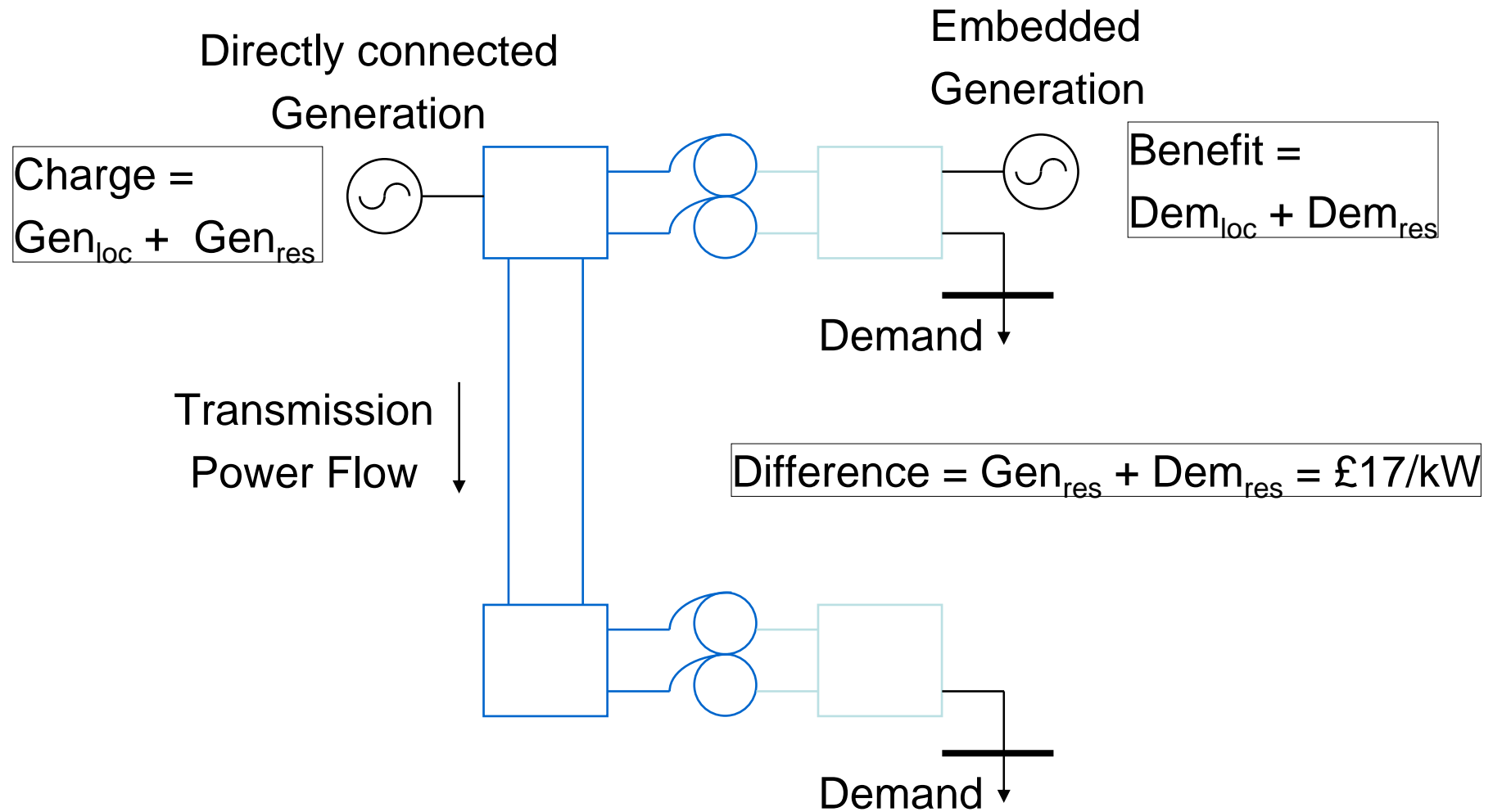

Embedded Benefit

What is the impact of DG?

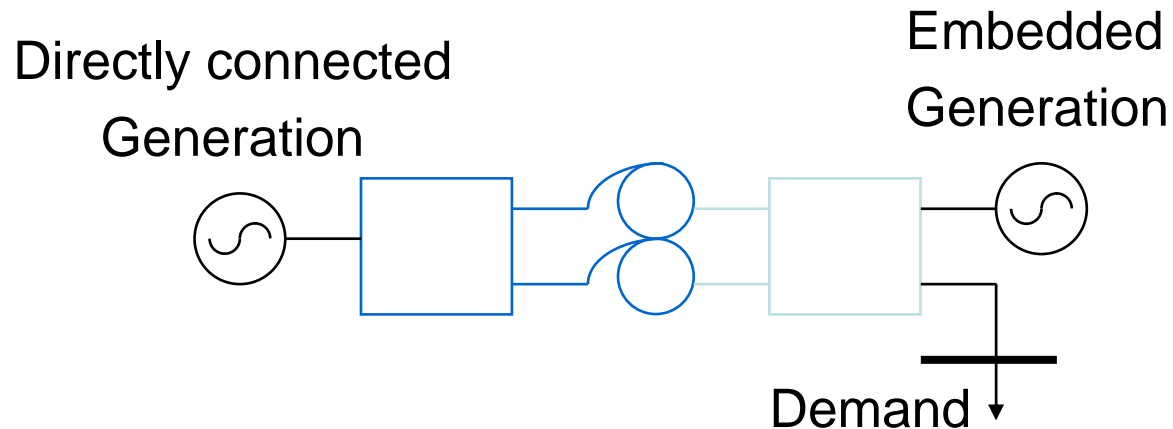

- ◆ Investment savings are two-fold:
 - ◆ Cost of connecting new generation
 - ◆ Less local works (if export less than designed import)
 - ◆ Exit substation assets
 - ◆ Off-set proposed reinforcements

Embedded Benefit

Avoided transmission costs (generation)

- ◆ Avoided costs of connecting new generation

	Local (£/kW)
South & South West	15
Thames Estuary	15
London	60
South Wales	15
East of England & Home Counties	10
West Midlands	5
East Midlands	5
North West & North Wales	30
Yorkshire & Lincolnshire	15
North East	15

- ◆ England & Wales average of £18.5/kW
- ◆ Annuitised over 40 years to approximately £1.5/kW

Embedded Benefit

Avoided transmission costs (demand)

- ◆ Indicative work suggests an England & Wales average of ~£60/kW
- ◆ Annuitised over 40 years this would give approximately £5/kW

- ◆ **Total avoided transmission costs could therefore be in the region of £6.5/kW**

Embedded Benefit

Next steps

- ◆ Avoided transmission costs for generation considered to be robust
 - ◆ derived from revenue drivers in the price control
- ◆ More detailed analysis of the avoided transmission investment for demand
 - ◆ Larger sample size
 - ◆ Consideration of Engineering Recommendation P2/6?

Embedded Benefit

P2/6 (1)

- ◆ Current distribution network planning standard
- ◆ DNOs have a licence obligation to plan and develop their systems in accordance
- ◆ Standard helps to deliver secure distribution networks
- ◆ Sets out the contribution to system security expected from distributed generation within a demand group, by technology
- ◆ How might we take this into account when assessing the value of the embedded benefit?

Embedded Benefit

P2/6 (2)

Type of generation	Number of Units									
	1	2	3	4	5	6	7	8	9	10+
Landfill gas*	63	69	73	75	77	78	79	79	80	80
CHP sewage using spark ignition*	40	48	51	52	53	54	55	55	56	56
Waste to energy**	58	64	69	71	73	74	75	75	76	77
CCGT**	63	69	73	75	77	78	79	79	80	80
CHP sewage using gas turbine**	53	61	65	67	69	70	71	71	72	73
	Persistence, T _m (hours)									
	0.5	2	3	18	24	120	360	>360		
Wind farm*	28	25	24	14	11	0	0	0		
Small hydro**	37	36	36	34	34	25	13	0		

* *High confidence data*

** *Sparse data*

Embedded Benefit

CISG

20 November 2007

nationalgrid